

brother

BAS-751

電子ポケットセッター 〈二列縫用〉

AUTOMATIC POCKET SETTER < DOUBLE SEAM >

AUTOMATISCHE TASCHENNÄHMASCHINE < DOPPELSÄUM >

MACHINE A COUDRE AUTOMATIQUE POUR POCHE < PIQÛRES DOUBLES >

MAQUINA DE COSER BOLSILLOS AUTOMATICA < COSTURA DOBLE >

PICK LOCATION
03W301603

ORDER: 538274



QUANTITY
1
EA
0 CASES
0 EA

BATCH: 11

PART: 195751101



PARTS BOOK BAS751

We're at your side.
brother.

3
ECES
REFERENCIA DE PIEZAS



パーツブックご利用に際して

1. 組単位で補給する部品は、 破線で示しております。
2. この本は1991年3月のデータに基づいて作成されたものです。
3. 部品は予告なしに設計変更される場合があります。
4. 部品コード欄が*となっている場合は、仕様別部品一覧表(127ページ)でお調べ下さい。

目 次

A. 主体関係	2
B. 針枠・天秤関係	4
C. 押エ関係	6
D. 糸切れ感知関係	8
E. ボトム関係	8
F. カマ関係	10
G. 給油・潤滑関係(1)	12
H. 糸通シ関係	14
J. 糸切り関係	16
K. 糸ユルメ関係	18
L. 電装品関係(1)	18
M. モータ関係	20
N. 針板関係	20
P. スタッカー関係	22
Q. 駆動側・送り関係	32
R. 送り案内関係	36
S. 折曲ゲ関係(特別注文部品)	38
T. 折曲ゲ上台関係	88
U. 給油・潤滑関係(2)	92
V. プリント基板関係	92
W. 糸巻関係	94
X. 空圧関係	96
Y. 電装品関係(2)	104
A1. マーカー関係	110
B1. 動力台関係	112
C1. 踏板関係	116
D1. 付属装置セット	116
D2. 付属装置セット	118
D3. 付属装置セット	120
D4. 付属装置セット	122
Z. 付属品関係	124
仕様別部品一覧表	127
索引	131

Hinweise zur Verwendung dieser Teileliste

1. Die Teile, die als kompletter Satz geliefert werden, sind mit einer  gestrichelten Linie umrandet.
2. Dieses Buch basiert auf den Informationen vom März 1991.
3. Modelländerungen sind vorbehalten.
4. Dieses Zeichen * in der Spalte "Parts No. (Teilnummer)" verweist auf die Teileliste auf Seite 127.

INHALTSVERZEICHNIS

A .	Maschinengehäuse	2
B .	Nadelstangen und Fadenabnahmevorrichtung	4
C .	Stoffdrückerfuß	6
D .	Fadenbruchfühler	8
E .	Unterer Mechanismus	8
F .	Greifervorrichtung	10
G .	Schmierung (1)	12
H .	Fadenführungsvorrichtung	14
J .	Fadenabschneidevorrichtung	16
K .	Spannungsverminderungsvorrichtung	18
L .	Stromversorgung (1)	18
M .	Motor	20
N .	Stichplattenmechanismus	20
P .	Anhäufung	22
Q .	Transportvorrichtung	32
R .	Transportführung	36
S .	Faltungsvorrichtung (SONDERZUBEHÖR)	38
T .	Faltungsvorrichtungsgrundplatte	88
U .	Schmierung (2)	92
V .	Leiterplatten	92
W .	Spuler	94
X .	Luftdruck	96
Y .	Stromversorgung (2)	104
A1 .	Markierungsvorrichtung	110
B1 .	Motorgestell	112
C1 .	Fußbetätigung	116
D1 .	Anbausatz	116
D2 .	Anbausatz	118
D3 .	Anbausatz	120
D4 .	Anbausatz	122
Z .	Zubehör	124
	ZUBEHÖRLISTE	127
	VERZEICHNIS	131

Notas para usar este Manual de Piezas

1. Las piezas suministradas como conjuntos completos se enmarcan con una línea punteada .
2. Este libro ha sido compilado basándose en los datos de que se disponía en marzo 1991.
3. Las piezas quedan sujetas a cambios de diseño sin aviso previo.
4. De haber un símbolo * junto al "Parts No. (Número de Pieza)", habrá que mirar la lista de piezas de la página 127.

INDICE

A .	Cuerpo de la máquina	2
B .	Mecanismo de la barra de aguja y tirahilos	4
C .	Mecanismo del prensatelas	6
D .	Mecanismo del sensor de cortes de hilo	8
E .	Mecanismo del fondo	8
F .	Mecanismo del cangrejo	10
G .	Lubricación (1)	12
H .	Mecanismo del enhebrado	14
J .	Mecanismo de la cortadura de hilos	16
K .	Mecanismo relajador de tensión	18
L .	Mecanismo del equipo de alimentación de corriente (1)	18
M .	Mecanismo del motor	20
N .	Mecanismo de la placa de aguja	20
P .	Mecanismo de apilador	22
Q .	Mecanismo de la alimentación, mando	32
R .	Mecanismo de la guía de alimentación	36
S .	Mecanismo de margen de plegado (PIEZAS A OPCION)	38
T .	Mecanismo base de margen de plegado	88
U .	Lubricación (2)	92
V .	Tableros de circuitos impresos	92
W .	Mecanismo del devanador de la canilla	94
X .	Mecanismo de la presión de aire	96
Y .	Mecanismo del equipo de alimentación de corriente (2)	104
A1 .	Mecanismo del marcador	110
B1 .	Mecanismo de la mesa de la máquina	112
C1 .	Mecanismo del pedal	116
D1 .	Juego de fijación	116
D2 .	Juego de fijación	118
D3 .	Juego de fijación	120
D4 .	Juego de fijación	122
Z .	Accesorios	124
	LISTA DE PIEZAS ACCESORIAS	127
	INDICE	131

Notes sur l'utilisation de ce manuel de pièces détachées



1. Les pièces fournies en tant qu'assemblages complets sont encadrées avec un trait pointillé .
2. Ce manuel a été fait d'après les renseignements valables au mois de Mars 1991.
3. Les pièces peuvent être sujettes à des modifications sans préavis.
4. Si le symbole * se trouve dans la colonne "Parts No. (N° de pièce)" veuillez la vous référer à la liste de pièces page 127.

TABLE DES MATIERES

A. Corps de la machine	2
B. Mécanisme de la barre à aiguille et releveur de fil	4
C. Mécanisme du pied presseur	6
D. Mécanisme du détecteur de cassure du fil	8
E. Mécanisme inférieur	8
F. Mécanisme du crochet rotatif	10
G. Lubrification (1)	12
H. Mécanisme de l'enfilage	14
J. Mécanisme de coupe-fil	16
K. Mécanisme de la lâche de tension	18
L. Mécanisme de l'équipement en alimentation électrique (1)	18
M. Mécanisme du moteur	20
N. Mécanisme de plaque à aiguille	20
P. Mécanisme de l'empileur	22
Q. Mécanisme d'alimentation, entraînement	32
R. Mécanisme du guide de l'entraînement	36
S. Mécanisme de marge d'ourlet (PIÈCES EN OPTION).....	38
T. Mécanisme de base de marge d'ourlet	88
U. Lubrification (2)	92
V. Circuits imprimés	92
W. Mécanisme du bobineur	94
X. Mécanisme de la pression d'air	96
Y. Mécanisme de l'équipement en alimentation électrique (2)	104
A1. Mécanisme du marqueur	110
B1. Mécanisme du plateau de la machine	112
C1. Mécanisme de la pédale	116
D1. Jeu d'accessoires	116
D2. Jeu d'accessoires	118
D3. Jeu d'accessoires	120
D4. Jeu d'accessoires	122
Z. Accessoires	124
LISTE DES PIÈCES ACCESSOIRES	127
INDEX	131

Notes for using this parts book

1. Parts supplied as complete assemblies are circled by a dotted line .
2. This book was prepared based on information available in March 1991.
3. Parts are subject to changes in design without prior notice.
4. If the symbol * is found in the "Parts No." column, refer to the parts list on page 127.

CONTENTS

A . Machine body	2
B . Needle bar and thread take-up mechanism	4
C . Presser foot mechanism	6
D . Thread breakage detector mechanism	8
E . Bottom mechanism	8
F . Rotary hook mechanism	10
G . Lubrication (1)	12
H . Threading mechanism	14
J . Thread trimmer mechanism	16
K . Tension release mechanism	18
L . Power supply equipment mechanism (1)	18
M . Motor mechanism	20
N . Needle plate mechanism	20
P . Stacker mechanism	22
Q . Drive, feed mechanism	32
R . Feed guide mechanism	36
S . Folding margin mechanism (OPTION PARTS)	38
T . Folding margin base mechanism	88
U . Lubrication (2)	92
V . Printed circuit boards mechanism	92
W . Bobbin winder mechanism	94
X . Air pressure mechanism	96
Y . Power supply equipment mechanism (2)	104
A1 . Marker mechanism	110
B1 . Power table	112
C1 . Foot switch pedal mechanism	116
D1 . Attachment set	116
D2 . Attachment set	118
D3 . Attachment set	120
D4 . Attachment set	122
Z . Accessories	124
DIFFERENT PARTS LIST	127
INDEX	131

A. 主体関係/Machine body/Maschinengehäuse/
Corps de la machine/Cuerpo de la máquina

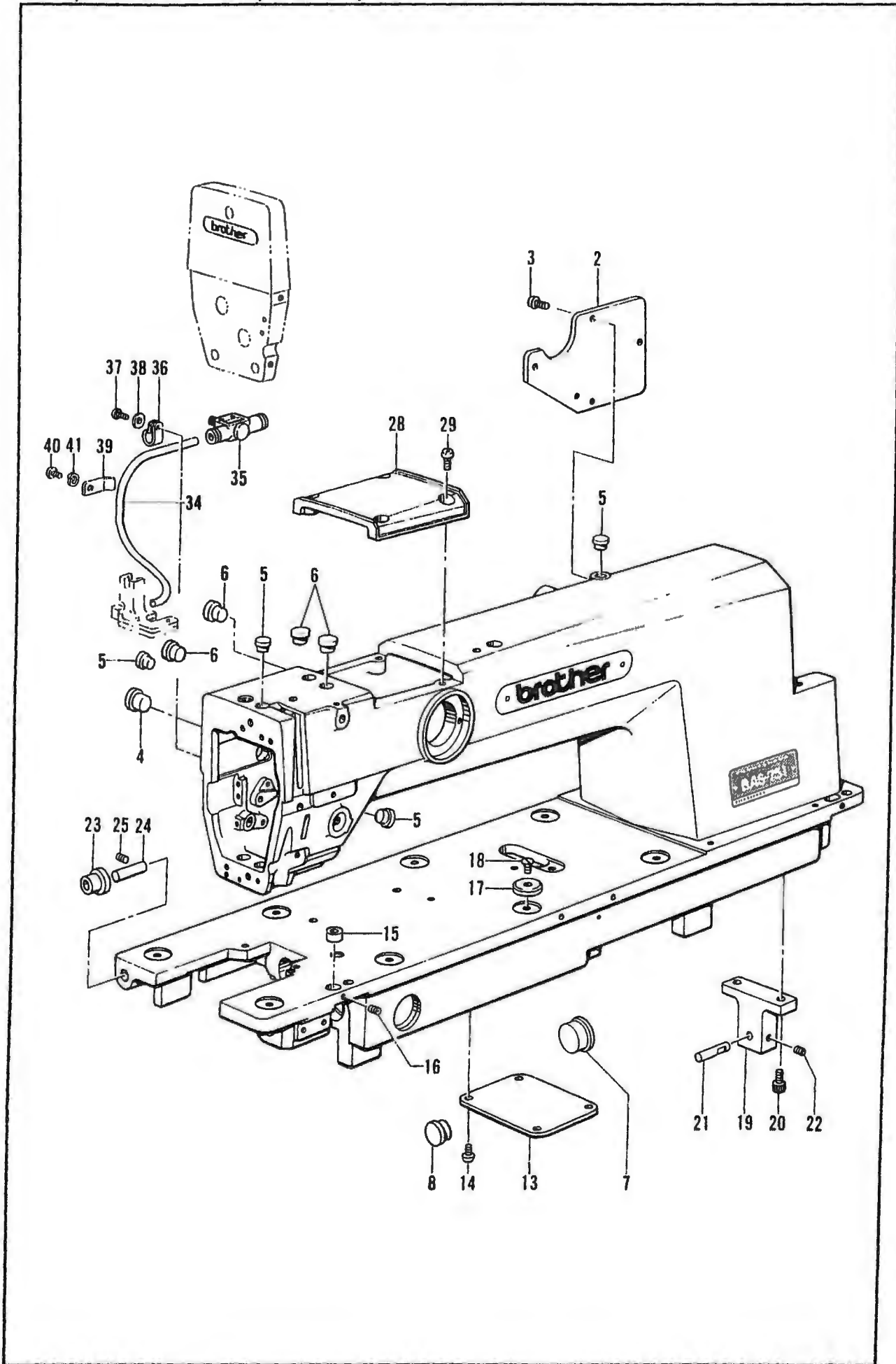

A. 主体関係/Machine body/Maschinengehäuse/
Corps de la machine/Cuerpo de la máquina

REI NO	CODE	O'LY	品名	NAME OF PARTS	RMKS
2	S11854009	1	ガ"ウイタ	REAR COVER	
3	062401012	4	ナヘ"コM4X10	SCREW M4X10	
4	104449009	1	メクラセン	OIL CAP	
5	104450109	4	メクラセン	OIL CAP	
6	104821009	4	メクラセン	OIL CAP	
7	147251009	1	メクラセン	OIL CAP	
8	150756009	1	メクラセン	OIL CAP	
13	S11855001	1	ソコフタ	BOTTOM LID	
14	062401012	4	ナヘ"コM4X10	SCREW M4X10	
15	S11856001	2	イチキ"メタル	POSITIONING BUSH	
16	014400422	2	アナトメネシ"4X4クホ"ミ	SET SCREW 4X4	
17	S11857000	4	ハリイタウケ	NEEDLE PLATE SUPPORT	
18	100032003	4	サラネシ"4.37	SCREW 4.37	
19	S11858001	1	トウフ"ササエタ"イ	HEAD SUPPORT STUD	
20	018501622	2	アナホ"ルト5X16	BOLT 5X16	
21	152866001	1	トウフ"ササエピン	PIN	
22	014500522	1	アナトメネシ"5クホ"ミ	SET SCREW 5	
23	152868009	2	ヘ"ツト"ヒンシ"クツシヨン	HINGE CUSHION	
24	152867000	2	ヘ"ツト"ヒンシ"シ"ク	HINGE SHAFT	
25	014500522	2	アナトメネシ"5クホ"ミ	SET SCREW 5	
28	S11860009	1	ウツフ"タ	UPPER LID	
29	062401012	4	ナヘ"コM4X10	SCREW M4X10	
34	S19080000	1	エアホ-ス4X2.5(L=135)	AIR TUBE 4X2.5 (L=135)	
35	S09197000	1	スピー"ト"コントローラ	SPEED CONTROLLER	
36	525664000	1	コート"ホルダ"6#	CORD HOLDER 6N	
37	062401006	1	ナヘ"コ4X10	SCREW 4X10	
38	025040233	1	ヒラサ"カ"ネチユウ4	PLAIN WASHER 4	
39	S02657001	1	コート"オサエ	CORD HOLDER	
40	062400812	1	ナヘ"コ4X8	SCREW 4X8	
41	028040242	1	ハ"ネサ"カ"ネ2-4	SPRING WASHER 2-4	

B. 針棒・天杆関係/Needle bar and thread take-up mechanism/Nadelstangen und Fadenabnahmevorrichtung/
Mécánisme de la barre à aiguille et releveur de fil/Mecanismo de la barra de aguja y tirahilos

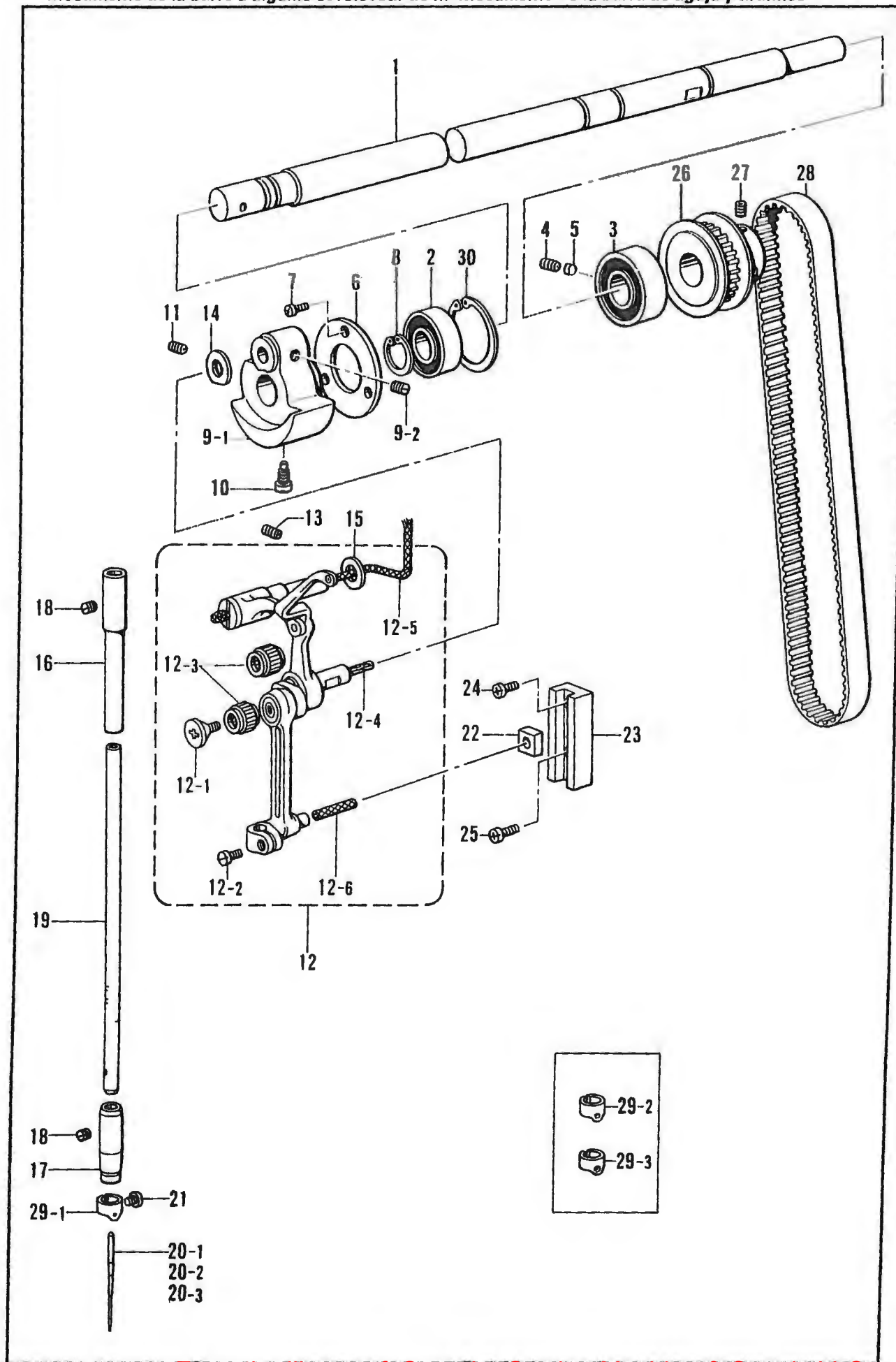

B. 針棒・天秤関係/Needle bar and thread take-up mechanism/Nadelstangen und Fadenabnahmevorrichtung/
Mécánisme de la barre à aiguille et releveur de fil/Mecanismo de la barra de aguja y tirahilos

REF NO	CODE	Q'TY	ヒンメイ	NAME OF PARTS	RMKS
1	S11862001	1	ウツシ"ク	UPPER SHAFT	
2	S11921000	1	タマシ"クウク6002DDU	BALL BEARING 6002DDU	
3	S11922000	1	タマシ"クウク6003DDU	BALL BEARING 6003DDU	
4	014400422	1	アナトメネシ"4X4クホ"ミ	SET SCREW 4X4	
5	S01234000	1	サ"ガ"ネ	WASHER	
6	S11863001	1	タマシ"クウクオサエ	BALL BEARING SUPPORT	
7	062401012	3	ナヘ"コM4X10	SCREW M4X10	
8	048150142	1	トメワシ"クヨウC15	STOP RING C15	
9	S02525001	1	デンヒ"ンクランククミ	THREAD TAKE-UP CRANK ASSEMBLY	
9-1	S02526000	1	デンヒ"ンクランク	THREAD TAKE-UP CRANK	
9-2	100251001	2	トメネシ"6.35	SET SCREW 6.35	
10	104464001	1	シメネシ"7.14	SCREW 7.14	
11	014771022	1	アナトメネシ"6.35クホ"ミ	SET SCREW 6.35	
12	S02527001	1	ハリホ"ウレンカククミ	THREAD TAKE-UP LEVER ASSEMBLY	
12-1	145465001	1	シメネシ"3.57L	SCREW 3.57 (L)	
12-2	140004001	1	シメネシ"3.57	SCREW 3.57	
12-3	147777000	2	ニート"ルヘ"アリング"	NEEDLE BEARING	
12-4	145624000	1	フェルト	FELT	
12-5	158726001	1	クミヒモ4X4 (L=120)	WICK 4X4 (L=120)	
12-6	158727001	1	クミヒモ4X4 (L=27)	WICK 4X4 (L=27)	
13	013781012	1	トメネシ"6.35クホ"ミ	SET SCREW 6.35	
14	110367001	1	サ"ガ"ネ	WASHER	
15	153596001	1	サ"ガ"ネ	WASHER	
16	117242001	1	ハリホ"ウメタルU	NEEDLE BAR BUSH (U)	
17	145468001	1	ハリホ"ウメタルD	NEEDLE BAR BUSH (D)	
18	100260001	2	トメネシ"5.95	SET SCREW 5.95	
19	114908001	1	ハリホ"ウ	NEEDLE BAR	
20-1	S11864010	1	ミシンハリ134SERV7 (#70)	NEEDLE 134SERV7 (#70)	
20-2	S11864012	1	ミシンハリ134SERV7 (#80)	NEEDLE 134SERV7 (#80)	
20-3	S11864016	1	ミシンハリ134SERV7 (#100)	NEEDLE 134SERV7 (#100)	
21	140553102	1	アタマツキトメネシ"3.18	SET SCREW 3.18	
22	102630001	1	ハリホ"ウアンナイカクコマ	NEEDLE BAR GUIDE SLIDE BLOCK	
23	145688000	1	ハリホ"ウアンナイ	NEEDLE BAR GUIDE	
24	062670412	1	ナヘ"コ357-40X4	SCREW 357X4	
25	062670612	1	ナヘ"コ357-40X6	SCREW 357X6	
26	S11865001	1	タイミンク"フー"リU	TIMING PULLEY (U)	
27	014770622	2	アナトメネシ"6.35クホ"ミ	SET SCREW 6.35	
28	S11866000	1	タイミンク"ヘ"ルト	TIMING BELT	
29-1	S11867001	1	ハリホ"ウイトアンナイ (ウスモノヨウ)	NEEDLE BAR THREAD GUIDE (THIN MATERIALS)	
29-2	S02736001	1	ハリホ"ウイトアンナイ (チユウアツモノヨウ)	NEEDLE BAR THREAD GUIDE (MEDIUM-THICK MATERIALS)	
29-3	151594001	1	ハリホ"ウイトアンナイ (アツモノヨウ)	NEEDLE BAR THREAD GUIDE (THICK MATERIALS)	
30	048320242	1	トメワアナヨウC32	STOP RING C32	

C. 押し関係/Presser foot mechanism/Stoffdrückerfuß/
Mécánisme du pied presseur/Mecanismo del prensatelas

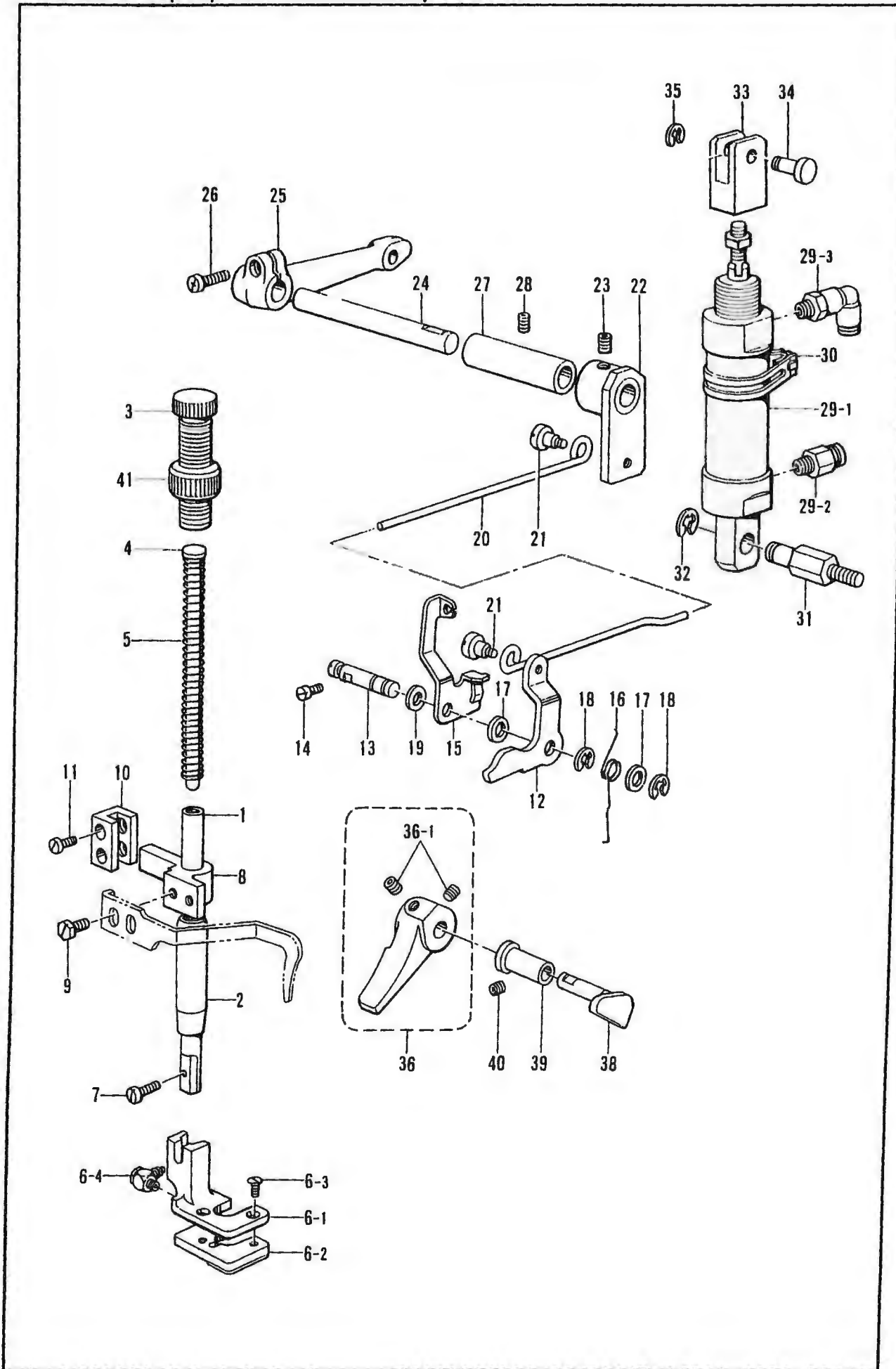

C. 押工関係/Presser foot mechanism/Stoffdrückerfuß/
 Mécanisme du pied presseur/Mecanismo del prensatelas

REF NO	CODE	Q'TY	品名	NAME OF PARTS	RMKS
1	111466001	1	オサエホ"ウ	PRESSER BAR	
2	145472001	1	オサエホ"ウメタル	PRESSER BAR BUSH	
3	141207001	1	オサエホ"ウセツネシ"	ADJUST SCREW	
4	141208001	1	オサエハ"ネアンナイ	SPRING GUIDE	
5	141728001	1	オサエハ"ネ	SPRING	
6	S19063101	1	オサエアシクミ	WORK CLAMP ASSEMBLY	
6 1	S19064001	1	オサエアシ	WORK CLAMP	
6 2	S19065101	1	オサエイタ	PRESSER PLATE	
6 3	102538007	2	サラネシ"3.57	SCREW 3.57	
6 4	S19068000	1	エルホ"M3	ELBOW M3	
7	S13385001	1	シメネシ"3.57X10	SCREW 3.57X10	
8	S00879001	1	オサエホ"ウタ"キ	PRESSER BAR GUIDE CLAMP	
9	142403001	1	ボルト5.95	BOLT 5.95	
10	S11871001	1	オサエホ"ウタ"キウク	PRESSER BAR CLAMP SUPPORT	
11	S11872001	2	シメネシ"4	SCREW 4	
12	145580001	1	オサエアケ"レハ"ー	PRESSER BAR LIFTER LEVER	
13	145474001	1	オサエアケ"レハ"ー"シ"ク	PRESSER BAR LIFTER LEVER SHAFT	
14	S01998001	1	アタマツキトメネシ"3.57	SET SCREW 3.57	
15	S02546201	1	イトユルメイタ	TENSION RELEASE PLATE	
16	145475101	1	オサエアケ"レハ"ー"ハ"ネ	SPRING	
17	109763002	2	サ"ガ"ネ	WASHER	
18	048040342	2	トメワE4	STOP RING E4	
19	159486001	1	サ"ガ"ネ	WASHER	
20	S11873001	1	オサエアケ"レンカン	PRESSER BAR LIFTER CONNECTING ROD	
21	145478001	2	タ"ンネシ"4.76	STUD SCREW 4.76	
22	S11874001	1	オサエアケ"ウデ"	PRESSER BAR LIFTER ARM	
23	014770622	2	アタメネシ"6.35クホ"ミ	SET SCREW 6.35	
24	S11875001	1	ヨウト"ウレンカン"シ"ク	ROCK CONNECTING SHAFT	
25	S11876001	1	レハ"ー	LEVER	
26	062711412	1	ナヘ"コ476-32X14	SCREW 476X14	
27	S11877001	1	オサエアケ"シ"クメタル	PRESSER BAR LIFTER SHAFT BUSH	
28	014500522	1	アタメネシ"5クホ"ミ	SET SCREW 5	
29	S11878000	1	オサエアケ"シリンダ"クミ	PRESSER BAR LIFTER CYLINDER ASSEMBLY	
29-1	S11879000	1	オサエアケ"シリンダ"	PRESSER BAR LIFTER CYLINDER	
29-2	S04910000	1	ハーフユニオン	HALF UNION	
29-3	S04909000	1	エルホ"ユニオン	ELBOW UNION	
30	S11880000	1	スイッチトリツケカナク"20	SWITCH SET METAL FITTING 20	
31	S11881001	1	シリンダ"ササエ	CYLINDER SUPPORT	
32	048070342	1	トメワE7	STOP RING E7	
33	S11882009	1	シリンダ"ツキ"テ	CYLINDER JOINT	
34	146153001	1	リンクピン	PIN	
35	048040342	1	トメワE4	STOP RING E4	
36	S13103009	1	オサエアケ"テコネシ"ツキ	PRESSER BAR LIFTER WITH SCREW	
36-1	014710522	2	アタメネシ"4.76クホ"ミ	SET SCREW 4.76	
38	S02551001	1	オサエアケ"クランク	PRESSER BAR LIFTER CRANK	
39	S11883001	1	オサエアケ"クランクメタル	PRESSER BAR LIFTER CRANK BUSH	
40	014400422	1	アタメネシ"4X4クホ"ミ	SET SCREW 4X4	
41	147846002	1	チヨウセツネシ"ツマミナツト	NUT	

D. 糸切れ感知関係 / Thread breakage detector mechanism / Fadenbruchfühler /
 Mécanisme du détecteur de cassure du fil / Mecanismo del sensor de cortes de hilo

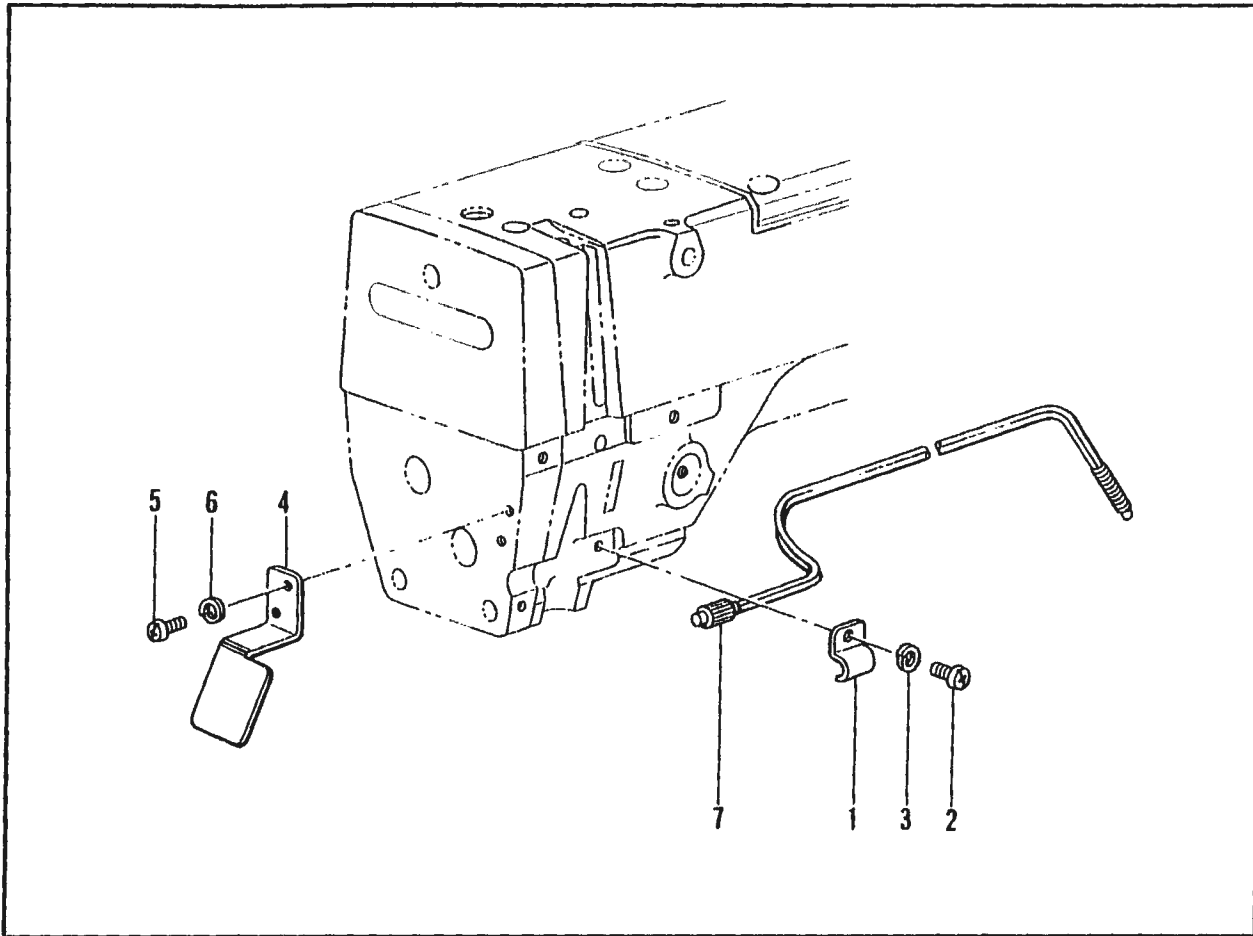

E. ボトム関係 / Bottom mechanism / Unterer Mechanismus /
 Mécanisme inférieur / Mecanismo del fondo

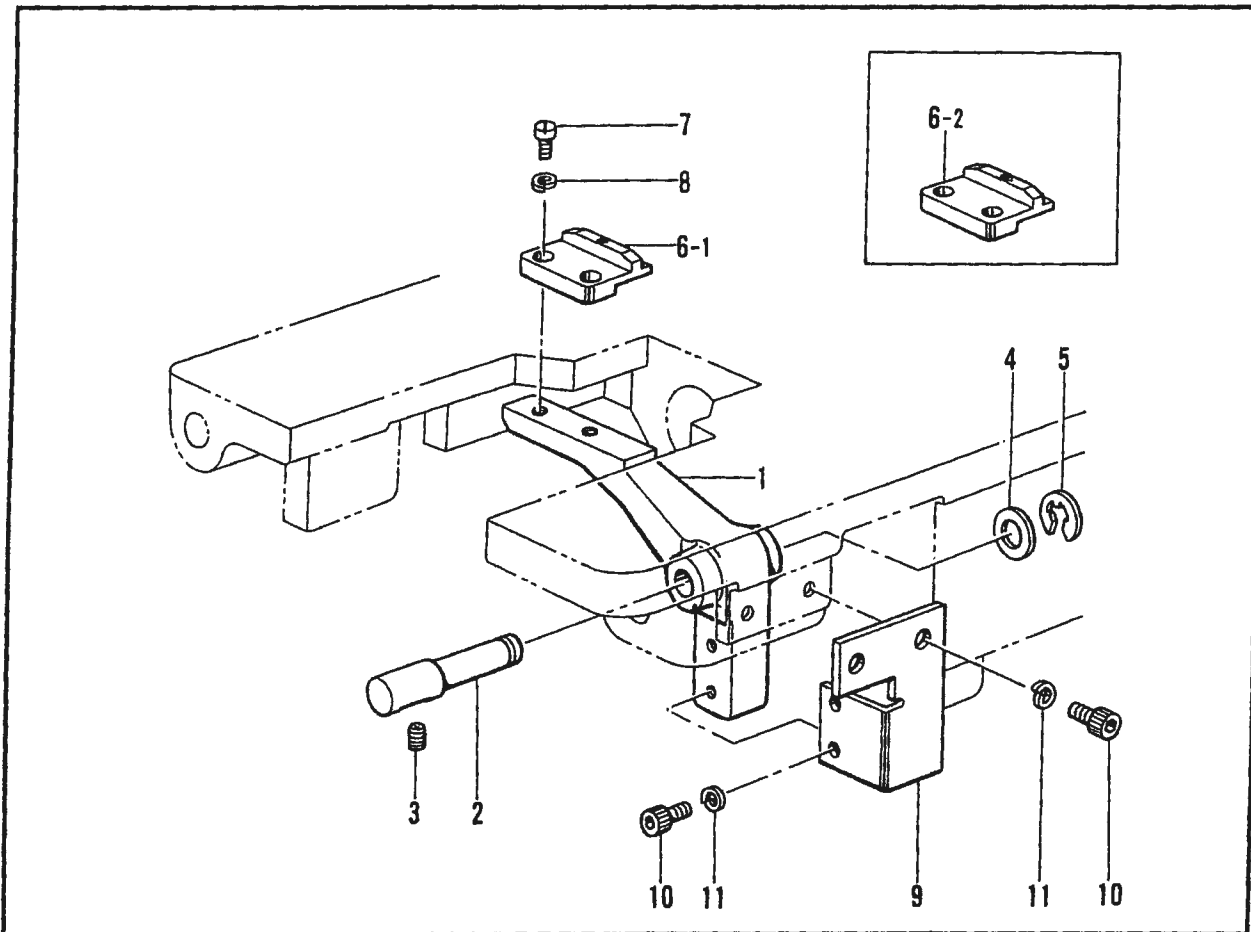

D. 糸切れ感知関係/Thread breakage detector mechanism/Fadenbruchfühler/
 Mécanisme du détecteur de cassure du fil/Mecanismo del sensor de cortes de hilo

REF NO.	CODE	Q'TY	ヒンメイ	NAME OF PARTS	RMKS
1	S11884001	1	センサートリックイタ	SENSOR SET PLATE	
2	062300612	1	ナヘ"コ3X6	SCREW 3X6	
3	028030242	1	ハ"ネサ"カ"ネ2-3	SPRING WASHER 2 3	
4	S11885001	1	センサーカハ"	SENSOR COVER	
5	062300612	2	ナヘ"コ3X6	SCREW 3X6	
6	028030242	2	ハ"ネサ"カ"ネ2-3	SPRING WASHER 2 3	
7	S11886000	1	ファイハ"ユニット	FIBER UNIT	

E. ボトム関係/Bottom mechanism/Unterer Mechanismus/
 Mécanisme inférieur/Mecanismo del fondo

REF.NO.	CODE	Q'TY	ヒンメイ	NAME OF PARTS	RMKS
1	S11887101	1	ボトムレハ"	BOTTOM LEVER	
2	S11888001	1	ボトムレハ"-シク	BOTTOM LEVER SHAFT	
3	014500522	1	アナトメネシ"5クホ"ミ	SET SCREW 5	
4	153113001	1	スラストサ"カ"ネ	THRUST WASHER	
5	048060342	1	トメフE6	STOP RING E6	
6-1	S11889001	1	ボトムフ"ランジ"ヤ (φ1.6MM)	BOTTOM PLUNGER (φ1.6MM)	
6-2	S14788001	1	ボトムフ"ランジ"ヤ (φ2MM)	BOTTOM PLUNGER (φ2MM)	
7	100080003	2	シメネシ"3.18	SCREW 3.18	
8	028030243	2	ハ"ネサ"カ"ネ2-3	SPRING WASHER 2-3	
9	S11890001	1	ボトムレハ"-ササエタ"イ	BOTTOM LEVER SUPPORT BRACKET	
10	018500822	4	アナボ"ルト5X8	BOLT 5X8	
11	028050242	4	ハ"ネサ"カ"ネ2-5	SPRING WASHER 2-5	

F. カマ関係/Rotary hook mechanism/Greifervorrichtung/
Mécanisme du crochet rotatif/Mecanismo del cangrejo

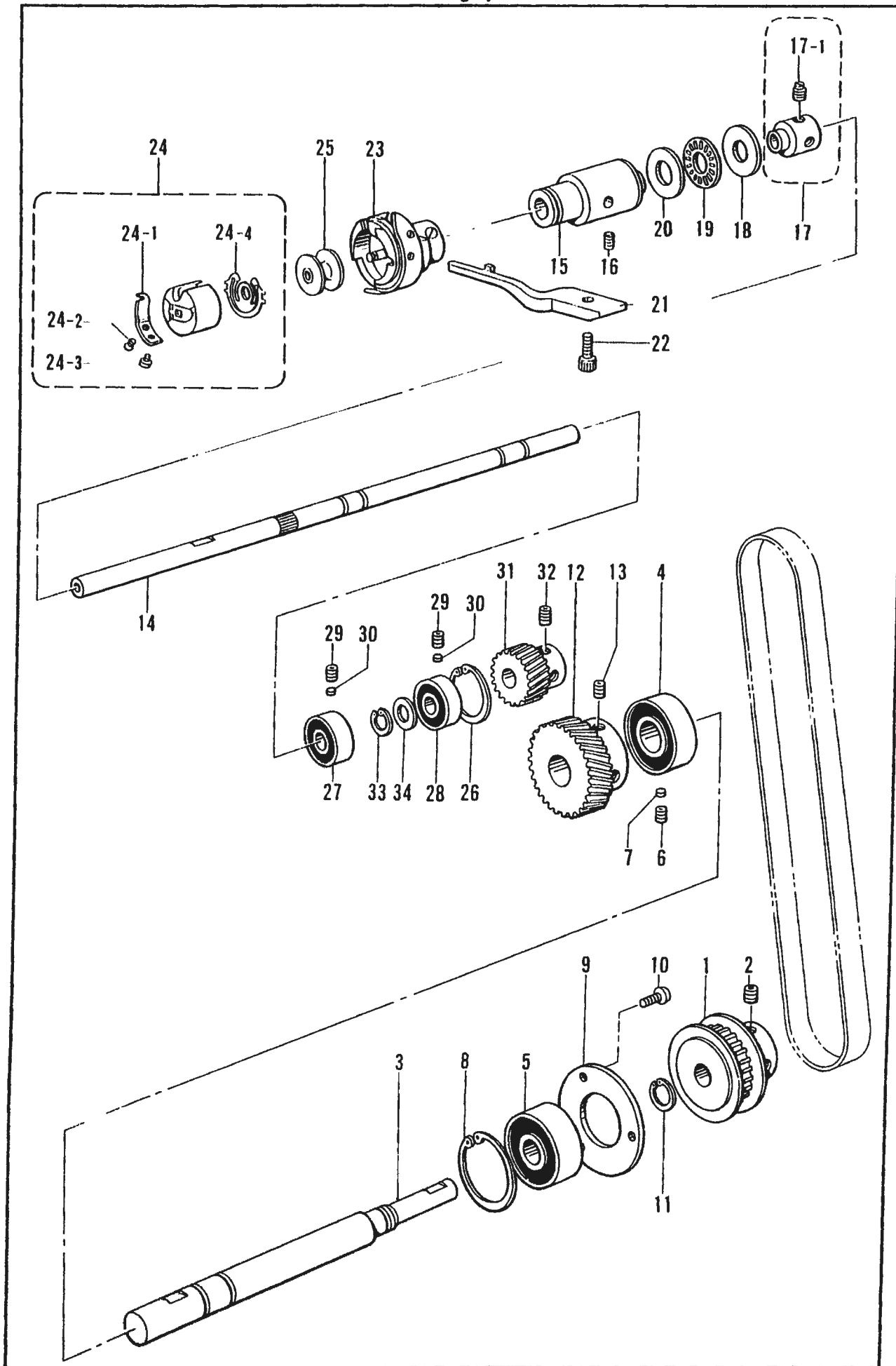

F. カマ関係/Rotary hook mechanism/Greifervorrichtung/
Mécanisme du crochet rotatif/Mecanismo del cangrejo

REF NO	CODE	Q'TY	ヒンメイ	NAME OF PARTS	RMKS
1	S11891001	1	タイミンク"フーリD	TIMING PULLEY (D)	
2	014770622	2	アナトメネシ"6.35クホ"ミ	SET SCREW 6.35	
3	S11892001	1	ンタシ"ク	LOWER SHAFT	
4	S11921000	1	タマシ"クウケ6002DDU	BALL BEARING 6002DDU	
5	S11923000	1	タマシ"クウケ6300DDU	BALL BEARING 6300DDU	
6	014400822	1	アナトメネシ"4クホ"ミ	SET SCREW 4	
7	S01234000	1	サ"カ"ネ	WASHER	
8	048350242	1	トメワアナコウC35	STOP RING C35	
9	S11893001	1	タマシ"クウケオサエ	BALL BEARING PRESSER	
10	062401012	3	ナヘ"コM4X10	SCREW M4X10	
11	048100142	1	トメワシ"クヨウC10	STOP RING C10	
12	S11894001	1	スパ"イラルキ"ヤ	SPIRAL GEAR	
13	014770622	3	アナトメネシ"6.35クホ"ミ	SET SCREW 6.35	
14	S11895001	1	カマシ"ク	ROTARY HOOK SHAFT	
15	S11896001	1	カマシ"クメタル	ROTARY HOOK SHAFT BUSH	
16	014400822	1	アナトメネシ"4クホ"ミ	SET SCREW 4	
17	183532001	1	セツ"カラーク"ミ	SET COLLAR ASSEMBLY	
17 1	101706001	2	トメネシ"6.35	SET SCREW 6.35	
18	S11898000	1	キト"ウリン	DRIVE TUMBLER	
19	S11899000	1	ニードル"へ"アリンク"	NEEDLE BEARING	
20	115007001	1	サ"カ"ネ	WASHER	
21	159324001	1	ウチカマトメ	BOBBIN CASE HOLDER POSITION BRACKET	
22	018401222	1	アナボ"ルト4X12	BOLT 4X12	
23	S16170001	1	コウソクカマ	ROTARY HOOK ASSEMBLY	
24	S03245001	1	ホ"ビ"ンケース"ク"ミ	BOBBIN CASE ASSEMBLY	
24-1	183388001	1	ホ"ビ"ンケース"チヨウシハ"ネ	TENSION SPRING	
24-2	183389001	1	チヨウシハ"ネ"チヨウセツ"ネシ"	ADJUST SCREW	
24-3	183390001	1	チヨウシハ"ネ"トメネシ"	SET SCREW	
24-4	S03246001	1	クウテン"ホ"ウシハ"ネ	BOBBIN TENSION SPRING	
25	146290001	1	ホ"ビ"ン	BOBBIN	
26	048220242	1	トメワアナコウC22	STOP RING C22	
27	072060860	1	タマシ"クウケ608VV	BALL BEARING 608VV	
28	S11924000	1	タマシ"クウケ608DDW1	BALL BEARING 608DDW1	
29	014400822	2	アナトメネシ"4クホ"ミ	SET SCREW 4	
30	S01234000	2	サ"カ"ネ	WASHER	
31	S11900001	1	ピ"ニオン	PINION	
32	014770622	3	アナトメネシ"6.35クホ"ミ	SET SCREW 6.35	
33	048080142	1	トメワシ"クヨウC8	STOP RING C8	
34	S01040001	1	サ"カ"ネ	WASHER	

G. 給油・潤滑関係(1)/Lubrication (1)/Schmierung (1)/
Lubrification (1)/Lubrificación (1)

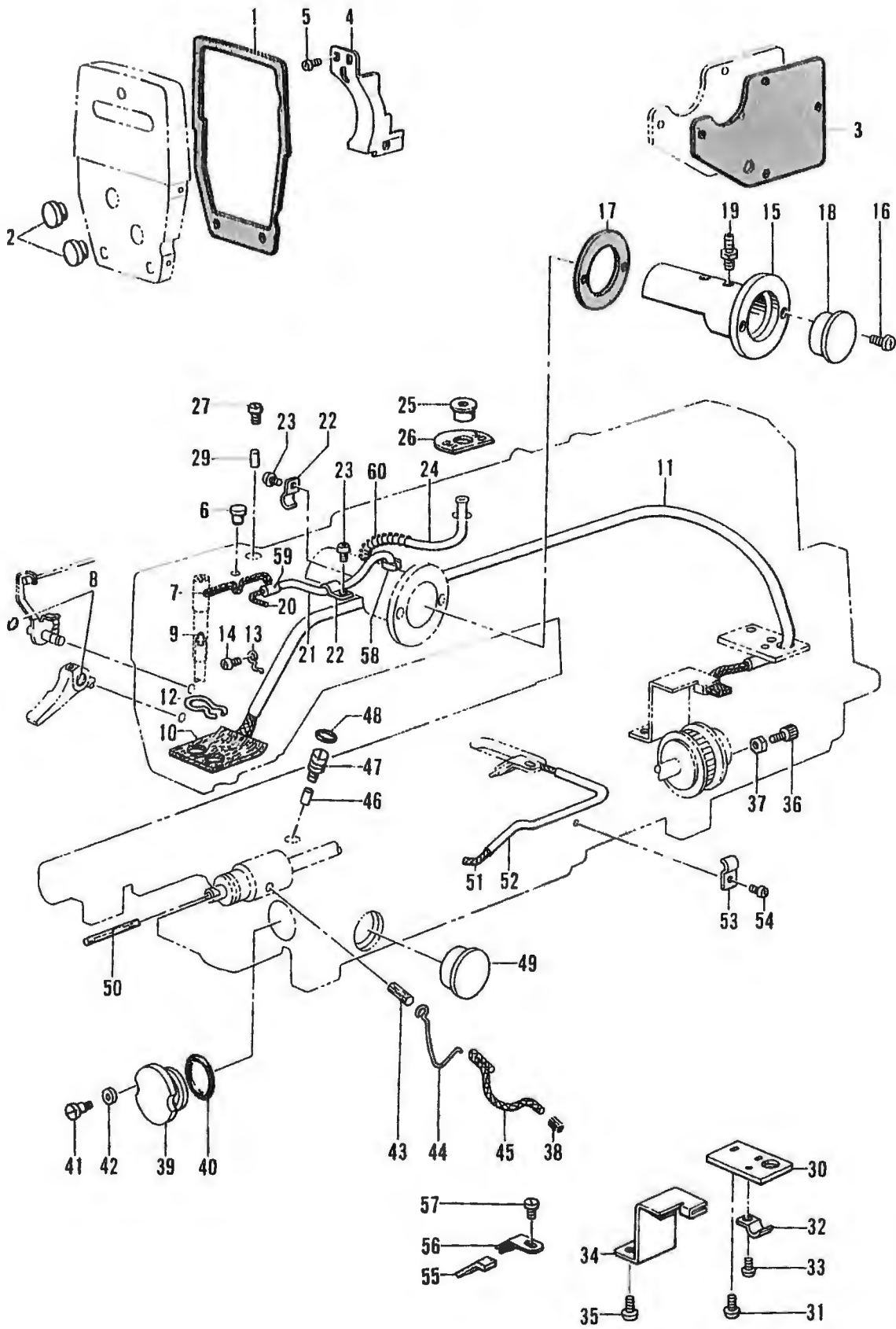

G. 給油・潤滑関係(1)/Lubrication (1)/Schmierung (1)/
Lubrification (1)/Lubricación (1)

REL NO	CODE	Q'TY	品名	NAME OF PARTS	RMKS
1	S11901000	1	メンイタパツキン	FACE PLATE PACKING	
2	104449009	2	メクラセン	OIL CAP	
3	S11902000	1	カクイタパツキン	REAR COVER PACKING	
4	S07229101	1	テンビ"ンオイルヨケイタ	OIL STOPPER PLATE	
5	062670512	2	ナヘ"コ357-40X5	SCREW 357X5	
6	111865009	1	オイルメクラセン	OIL CAP	
7	108804001	1	クミヒモ4X4(L=510)	WICK 4X4 (L=510)	
8	081001670	2	Oリング"PW1	O RING PW1	
9	111863001	1	ハリボ"ウセン	NEEDLE BAR CORK	
10	S11903000	1	スイアケ"フェルトクミ	FELT ASSEMBLY	
11	S11906000	1	ヒ"ニルチューブ"	OIL TUBE	
12	145737001	1	フェルトオサエ	FELT SUPPORT	
13	117150001	1	コード"ササエカネ	CORD SUPPORT	
14	062670512	1	ナヘ"コ357-40X5	SCREW 357X5	
15	S11907009	1	オイルタンク	OIL TANK	
16	062401012	2	ナヘ"コM4X10	SCREW M4X10	
17	S11908000	1	オイルタンクパツキン	OIL TANK PACKING	
18	152948001	1	オイルボ"ツトマト"	OIL GAUGE WINDOW	
19	142359001	2	オイルクチ	OIL FEEDING PIPE	
20	S11909000	1	クミヒモ3X3(L=250)	WICK 3X3 (L=250)	
21	S11910000	1	ヒ"ニルチューブ"(L=115)	OIL TUBE (L=115)	
22	140647001	2	コード"オサエ	CORD HOLDER	
23	062300612	2	ナヘ"コ3X6	SCREW 3X6	
24	S11945000	1	ヒ"ニルチューブ"	OIL TUBE	
25	112758009	1	ヘ"ツト"オイルフタ	OIL CAP	
26	S11911009	1	オイルシート	OIL SEAT	
27	145619001	1	シメネジ"6.35	SCREW 6.35	
29	S07478000	1	ゴムオサエ	RUBBER PRESSER	
30	S11912001	1	チューブ"アンナイ	TUBE GUIDE	
31	062400812	2	ナヘ"コ4X8	SCREW 4X8	
32	140647001	1	コード"オサエ	CORD HOLDER	
33	062300612	1	ナヘ"コ3X6	SCREW 3X6	
34	S11913001	1	キユウユササエ	OIL SUPPORT	
35	062400812	2	ナヘ"コ4X8	SCREW 4X8	
36	018401622	1	アナボ"ルト4X16	BOLT 4X16	
37	021400202	1	2シユナツト4	NUT 4	
38	157843001	1	ゴムセン6X6	OIL CAP 6X6	
39	157844000	1	アブ"ラマト"	OIL GAUGE WINDOW	
40	081024070	1	Oリング"P24	O RING P24	
41	153112001	2	タ"ンネジ"3.57	STUD SCREW 3.57	
42	140208001	2	サ"カ"ネ	WASHER	
43	S11915000	1	フェルト5X16	FELT 5X16	
44	S11916001	1	クミヒモササエ	WICK SUPPORT	
45	157840000	1	クミヒモ3X3(L=100)	WICK 3X3 (L=100)	
46	S07478000	1	ゴムオサエ	RUBBER PRESSER	
47	S11917001	1	オイルチヨウセツネジ"	ADJUST SCREW	
48	081005670	1	Oリング"PW5	O RING PW5	
49	152948001	1	オイルボ"ツトマト"	OIL GAUGE WINDOW	
50	S11918000	1	フェルト	FELT	
51	S11909000	1	クミヒモ3X3(L=250)	WICK 3X3 (L=250)	
52	S11919000	1	ヒ"ニルチューブ"(L=160)	OIL TUBE (L=160)	
53	140647001	1	コード"オサエ	CORD HOLDER	
54	062300612	1	ナヘ"コ3X6	SCREW 3X6	
55	S11914000	1	フェルト	FELT	
56	S11920001	1	フェルトササエ	FELT SUPPORT	
57	106629002	1	シメネジ"4.37	SCREW 4.37	
58	S07469001	1	チューブ"カシメ	TUBE CALKING	
59	S11944000	1	ゴムリング"	RUBBER RING	
60	144086001	1	オサエボ"ウアケ"ハ"ネ	SPRING	

17. 糸通し機構 / Threading mechanism / FadenführungsVorrichtung /
Mécánisme de l'enfilage / Mecanismo del enhebrado

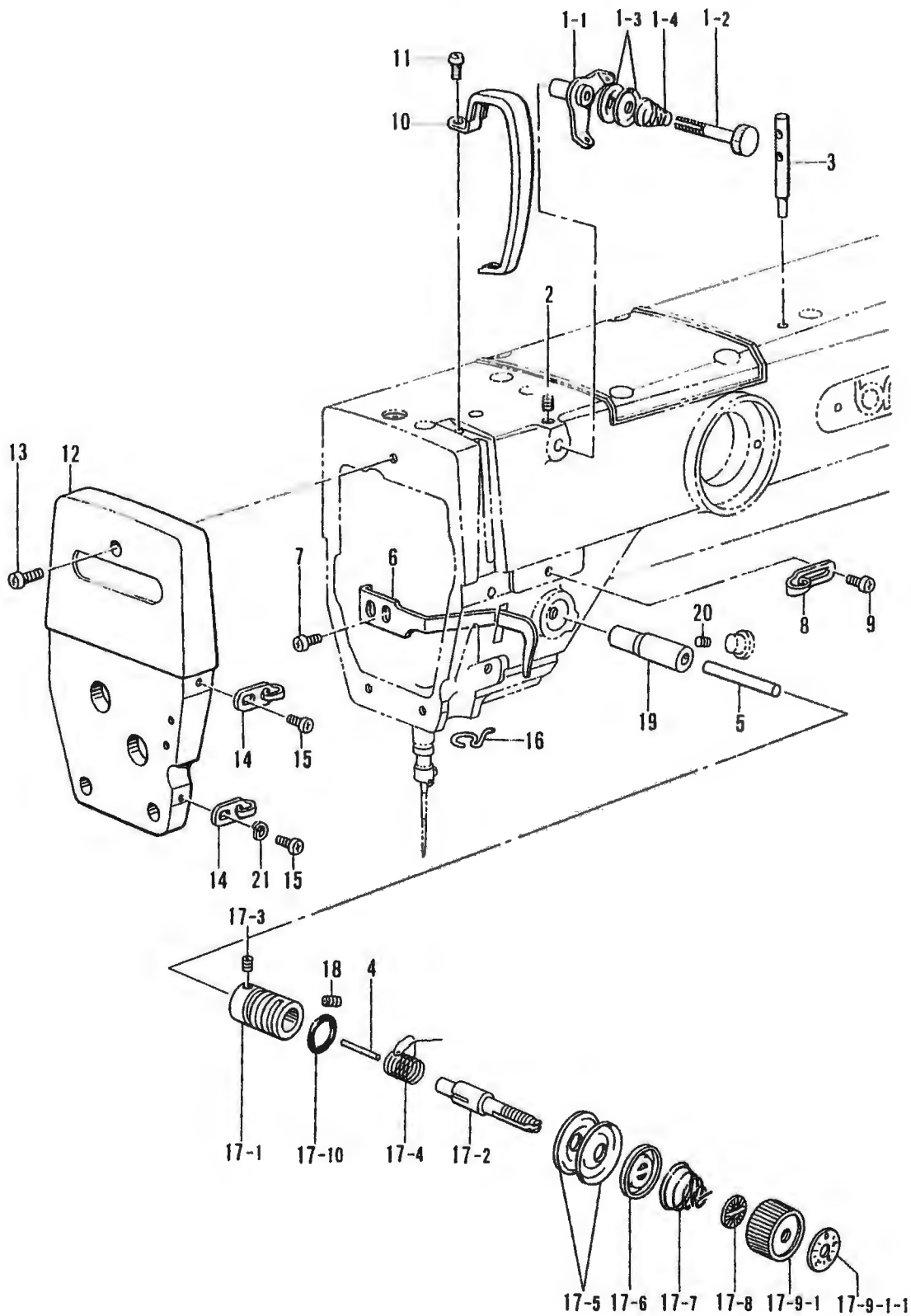

H. 糸通シ関係 / Threading mechanism / FadenführungsVorrichtung /
Mécánisme de l'enfilage / Mecanismo del enhebrado

REL NO	CODE	Q'TY	ヒンメイ	NAME OF PARTS	RMKS
1	183377001	1	ﾌﾟﾚﾃﾝｼﾞｮﾝｸﾞﾐA	PRE-TENSION ASSEMBLY (A)	
1 1	S02611001	1	ｲﾄｱﾝﾅｲ	THREAD GUIDE	
1 2	S02612001	1	ｲﾄｱﾝﾅｲﾁｮｳｼﾾ"ｳ	PRE TENSION STUD	
1 3	144504001	2	ｲﾄｱﾝﾅｲｻﾗ	THREAD GUIDE DISC	
1 4	154560001	1	ﾌﾟﾚﾃﾝｼﾞｮﾝﾊﾞ"ﾈA	PRE TENSION SPRING (A)	
2	014400522	1	ｱﾅｸﾾ"ﾐ4X5	SET SCREW 4X5	
3	147557101	1	ｲﾄﾀﾃﾾ"ｳ	SPOOL PIN	
4	100400000	1	ｲﾄﾕﾙﾾﾾ"ｳ	PIN	
5	S07972001	1	ｲﾄﾕﾙﾾﾾ"ｳ	TENSION RELEASE STUD	
6	111469101	1	ｵｻｴﾾ"ｳﾀ"ｷｲﾄｱﾝﾅｲ	PRESSER BAR CLAMP THREAD GUIDE	
7	062680712	1	ﾅﾾ"ｺ437-40X7	SCREW 437X7	
8	145522001	1	ｱｰﾓｲﾄｱﾝﾅｲR	ARM THREAD GUIDE (R)	
9	060670612	1	ﾊﾞ"ｲﾝﾄ"357-40X6	SCREW 357X6	
10	S02614109	1	ﾃﾝﾋﾞ"ﾝｶﾊﾞｰ	THREAD TAKE-UP COVER	
11	062400812	1	ﾅﾾ"ｺ4X8	SCREW 4X8	
12	S11925009	1	ﾒﾝｲﾀ	FACE PLATE	
13	062401012	3	ﾅﾾ"ｺM4X10	SCREW M4X10	
14	S02617001	2	ﾒﾝｲﾀｲﾄｱﾝﾅｲ	FACE PLATE THREAD GUIDE	
15	060670612	2	ﾊﾞ"ｲﾝﾄ"357-40X6	SCREW 357X6	
16	100573001	1	ﾊﾘﾾ"ｳﾾ"ﾀﾙDｲﾄｱﾝﾅｲ	NEEDLE BAR BUSH (D) THREAD GUIDE	
17	183513009	1	ｲﾄﾁｮｳｼﾾ"ｳﾀ"ｲｸﾐ	THREAD TENSION BRACKET ASSEMBLY	
17-1	S03254001	1	ｲﾄﾁｮｳｼﾾ"ｳﾀ"ｲ	THREAD TENSION BRACKET	
17-2	116922001	1	ｲﾄﾁｮｳｼﾾ"ｳ	TENSION STUD	
17-3	100402004	1	ﾄﾾ"ﾈｼ"3.57	SET SCREW 3.57	
17-4	S02620001	1	ｲﾄﾄﾘﾊ"ﾈ	SPRING	
17-5	145446001	2	ｲﾄﾁｮｳｼ"ｻﾗ	TENSION DISC	
17-6	159805001	1	ｲﾄﾁｮｳｼ"ｻﾗ"ｵｻｴ	TENSION DISC PRESSER	
17-7	104525001	1	ｲﾄﾁｮｳｼ"ﾊ"ﾈ	TENSION SPRING	
17-8	S02624001	1	ﾁｮｳｼ"ﾊ"ﾈ"ｳ"ｴ"ｻ"ｶ"ﾈ	WASHER	
17-9	S11182009	1	ｲﾄﾁｮｳｼ"ﾅ"ｯ"ｯ"ｸ"ﾐ	THREAD TENSION NUT ASSEMBLY	
17-9-1	S11183009	1	ﾁｮｳ"ｳ"ｴ"ｯ"ｯ"ﾾ"ﾐ	CONTROL DIAL	
17-9-1-1	S11184009	1	ｲﾄﾁｮｳｼ"ﾾ"ﾾ"ｲ"ﾀ	TENSION ADJUST SCALE PLATE	
17-10	114294001	1	ｵ"ﾘﾝｸ"	O RING	
18	103950003	1	ﾄﾾ"ﾈ"ｼ"5.95	SET SCREW 5.95	
19	S07901000	1	ｲﾄﾕﾙ"ﾾ"ﾾ"ﾀﾙ	TENSION RELEASE BUSH	
20	014400822	1	ｱ"ﾅ"ﾄ"ﾾ"ﾈ"ｼ"4"ｸ"ﾾ"ﾐ	SET SCREW 4	
21	028350242	1	ﾊ"ﾾ"ﾈ"ｻ"ｶ"ﾾ"2-3.5	SPRING WASHER 2-3.5	

J. 糸切り関係 / I thread trimmer mechanism / Fadenabschneidevorrichtung /
Mécanisme de coupe-fil / Mecanismo de la cortadura de hilos

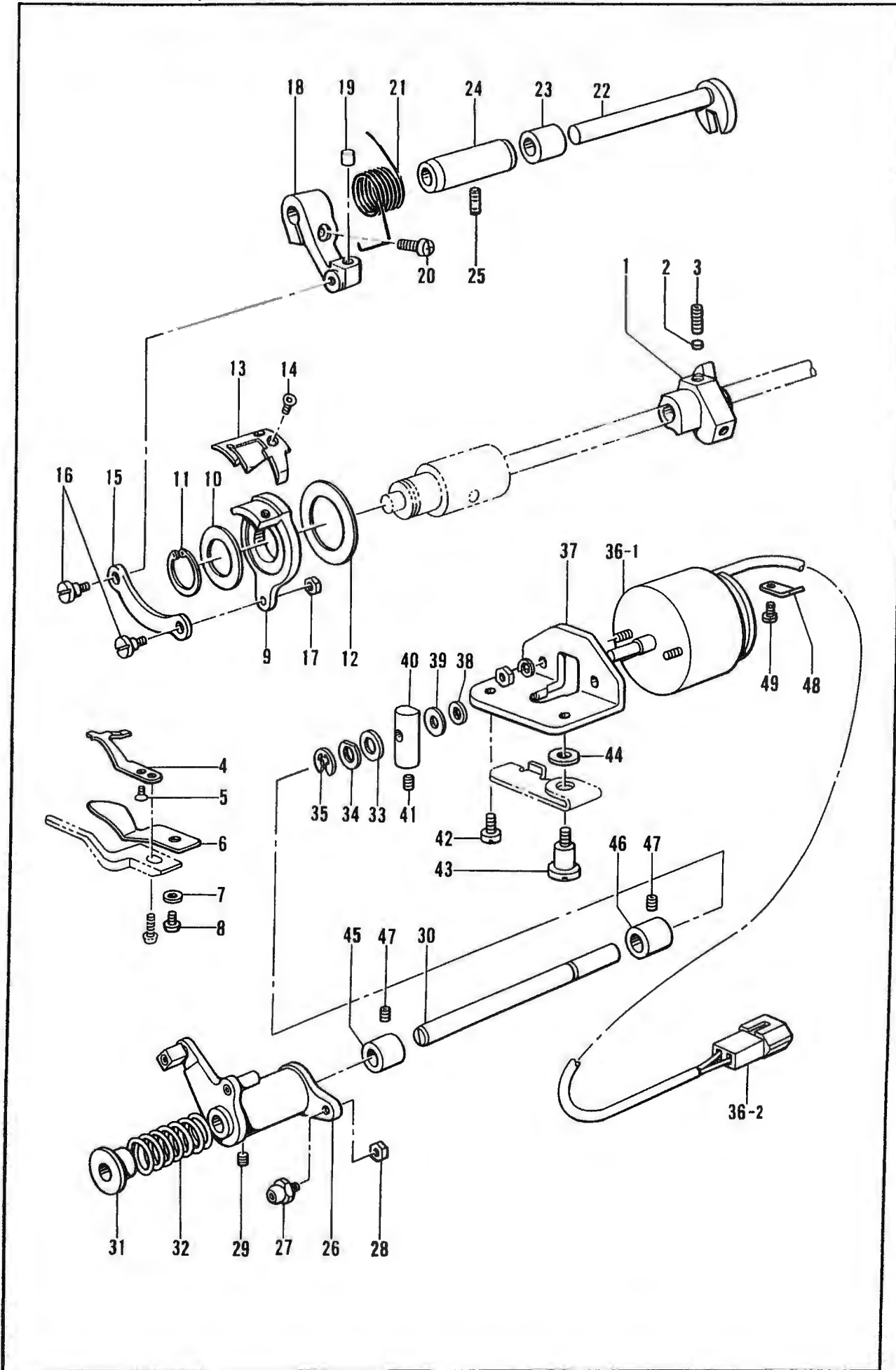

J. ホトリ関係 / I thread trimmer mechanism / Fadenabschneidevorrichtung /
 Mécanisme de coupe-fil / Mecanismo de la cortadura de hilos

REF NO	CODE	Q'TY	ヒンメイ	NAME OF PARTS	RMKS
1	S00337001	1	イトキリカム	THREAD TRIMMER CAM	
2	154667000	2	カンザ"5.3	WASHER 5.3	
3	014771022	2	アナトメネジ"6.35クホ"ミ	SET SCREW 6.35	
4	S02637001	1	コテイハ	FIXED KNIFE	
5	102843004	1	サラネジ"3.57	SCREW 3.57	
6	S02643001	1	イトサハ"キ	LOWER THREAD FINGER	
7	100645003	1	サ"ガ"ネ	WASHER	
8	062400812	1	ナヘ"コ4X8	SCREW 4X8	
9	156619001	1	イトキリホルタ"	MOVABLE KNIFE HOLDER	
10	156620000	1	スラストサ"ガ"ネ	THRUST WASHER	
11	048170145	1	トメワシ"クヨウC17	STOP RING C17	
12	S11926001	1	サ"ガ"ネ	WASHER	
13	S02645001	1	イト"ウハ	MOVABLE KNIFE	
14	148537001	2	サラネジ"4.37	SCREW 4.37	
15	154576001	1	イトキリレンカン	THREAD TRIMMER CONNECTING ROD	
16	151987001	2	タ"ンネジ"4.37	STUD SCREW 4.37	
17	102571003	1	ナツト4.37	NUT 4.37	
18	154577001	1	イトキリレハ"ー	THREAD TRIMMER LEVER	
19	154578000	1	レハ"ー"ストツハ"	THREAD TRIMMER LEVER STOPPER	
20	062711412	1	ナヘ"コ4.76-32X14	SCREW 476X14	
21	154579001	1	イトキリレハ"ー"ハ"ネ	SPRING	
22	S02647001	1	フタマタシ"ク	FORKED SHAFT	
23	S02648001	1	カラ"ー	COLLAR	
24	154581001	1	フタマタシ"ク"メタル	FORKED SHAFT BUSH	
25	014400822	1	アナトメネジ"4クホ"ミ	SET SCREW 4	
26	154582001	1	イトキリカムレハ"ー"クミ	THREAD TRIMMER CAM LEVER ASSEMBLY	
27	154590001	1	コロシ"クCクミ	ROLLER SHAFT (C) ASSEMBLY	
28	105234003	1	ナツト4.37	NUT 4.37	
29	014770622	1	アナトメネジ"6.35クホ"ミ	SET SCREW 6.35	
30	154593001	1	イトキリカムレハ"ー"シ"ク	THREAD TRIMMER CAM LEVER SHAFT	
31	154594000	1	カラ"ー	COLLAR	
32	154595001	1	カムレハ"ー"モト"シハ"ネ	SPRING	
33	154596000	1	イトキリカムレハ"ー"クツシヨ"ン	CUSHION	
34	110367001	1	サ"ガ"ネ	WASHER	
35	048060342	1	トメワE6	STOP RING E6	
36	S11927009	1	イトキリソレノイト"クミ	THREAD TRIMMER SOLENOID ASSEMBLY	
36-1	S11928009	1	イトキリソレノイト"	THREAD TRIMMER SOLENOID	
36-2	143488000	1	ナイロンコネクター	NYLON CONNECTOR	
37	154598001	1	イトキリソレノイト"ク"イ	THREAD TRIMMER SOLENOID BRACKET	
38	154599000	1	ソレノイト"クツシヨ"ン	SOLENOID CUSHION	
39	S02652001	1	サ"ガ"ネ	WASHER	
40	S02654001	1	ソレノイト"レハ"ー	SOLENOID LEVER	
41	014680622	1	アナトメネジ"4.37クホ"ミ	SET SCREW 4.37	
42	110201001	1	シメネジ"6.35	SCREW 6.35	
43	S02655001	1	タ"ンネジ"6.35	STUD SCREW 6.35	
44	155559001	1	ヒラサ"ガ"ネ	PLAIN WASHER	
45	S11929001	1	イトキリシ"ク"メタルL	THREAD TRIMMER SHAFT BUSH (L)	
46	S11930001	1	イトキリシ"ク"メタルR	THREAD TRIMMER SHAFT BUSH (R)	
47	014400822	2	アナトメネジ"4クホ"ミ	SET SCREW 4	
48	S02657001	1	コート"オサ"エ	CORD HOLDER	
49	062300612	1	ナヘ"コ3X6	SCREW 3X6	

K. 糸ユルメ関係/Tension release mechanism/Spannungsverminderungsvorrichtung/
 Mécanisme de la lâche de tension/Mecanismo relajador de tensión

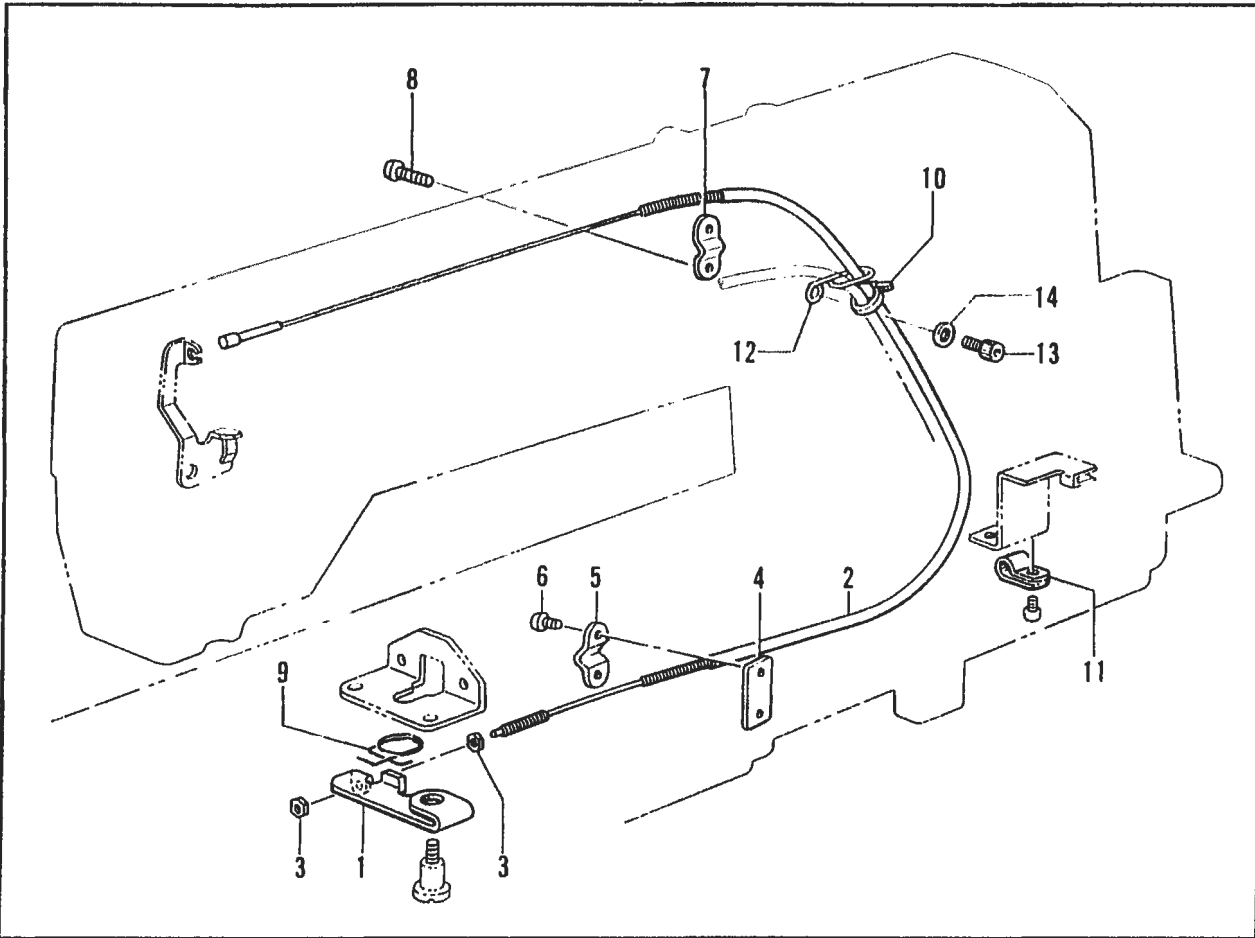

L. 電装品関係(1)/Power supply equipment mechanism (1)/Stromversorgung (1)/
 Mécanisme de l'équipement en alimentation électrique (1)/
 Mecanismo del equipo de alimentación de corriente (1)

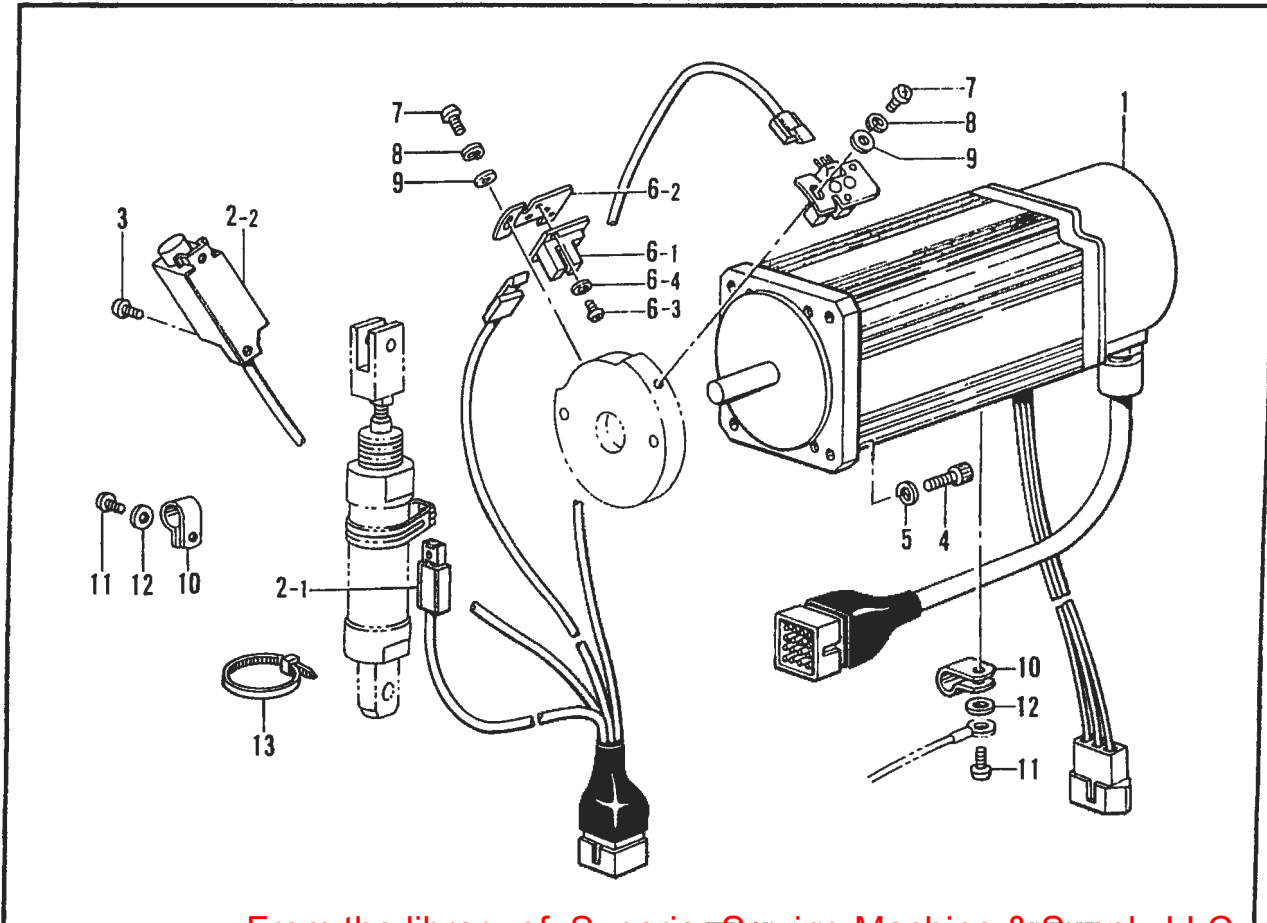

K. 糸ユルメ関係/Tension release mechanism/Spannungsverminderungsvorrichtung/
Mécánisme de la lâche de tension/Mecanismo relajador de tensión

HLF NO.	CODE	Q'TY	ヒンメイ	NAME OF PARTS	RMKS
1	S02658001	1	イトユルメレバー	TENSION RELEASE LEVER	
2	S11931001	1	イトユルメワイヤー	TENSION RELEASE WIRE	
3	110161004	2	ナツト4.76	NUT 4.76	
4	S11932001	1	ワイヤートリツケイタ	WIRE SET PLATE	
5	154607001	1	イトユルメワイヤーオサエD	TENSION RELEASE WIRE HOLDER (D)	
6	062670812	2	ナヘ"コ357-40X8	SCREW 357X8	
7	S11933001	1	イトユルメワイヤーオサエ	TENSION RELEASE WIRE HOLDER	
8	062671612	2	ナヘ"コ357-40X16	SCREW 357X16	
9	S03670001	1	イトユルメモトシハネ	SPRING	
10	340400001	1	ユニタイバンド	BEAD BAND	
11	S00480000	1	コート"ホルタ"5N	CORD HOLDER 5N	
12	S07467001	1	チューブ"ササエ	TUBE SUPPORT	
13	018400822	1	アナホル"ルト4X8	BOLT 4X8	
14	025040232	1	ヒラサ"ガ"ネチユウ4	PLAIN WASHER 4	

L. 電装品関係(1)/Power supply equipment mechanism (1)/Stromversorgung (1)/
Mécánisme de l'équipement en alimentation électrique (1)/
Mecanismo del equipo de alimentación de corriente (1)

REF.NO.	CODE	Q'TY	ヒンメイ	NAME OF PARTS	RMKS
1	S11737100	1	ミシンモータクミ	MACHINE MOTOR ASSEMBLY	
2	S11714300	1	ミシンセンサクミ	MACHINE SENSOR ASSEMBLY	
2-1	S11830300	1	シリンダ"センサ1	CYLINDER SENSOR-1	
2-2	S11831200	1	アンプ"ユニットクミ	AMP UNIT ASSEMBLY	
3	062401012	1	ナヘ"コM4X10	SCREW M4X10	
4	018501622	4	アナホル"ルト5X16	BOLT 5X16	
5	028050242	4	ハ"ネサ"ガ"ネ2-5	SPRING WASHER 2-5	
6	S12463001	2	センサキハ"ンクミ1	SENSOR CIRCUIT BOARD ASSEMBLY-1	
6-1	S11828000	2	センサキハ"ンクミ	SENSOR CIRCUIT BOARD ASSEMBLY	
6-2	S12461001	2	センサフ"ラケット	SENSOR BRACKET	
6-3	062300612	4	ナヘ"コ3X6	SCREW 3X6	
6-4	028030242	4	ハ"ネサ"ガ"ネ2-3	SPRING WASHER 2-3	
7	062300612	2	ナヘ"コ3X6	SCREW 3X6	
8	028030242	2	ハ"ネサ"ガ"ネ2-3	SPRING WASHER 2-3	
9	025030132	2	ヒラサ"ガ"ネシヨウ3	PLAIN WASHER 3	
10	S00480000	4	コート"ホルタ"5N	CORD HOLDER 5N	
11	062401006	4	ナヘ"コ4X10	SCREW 4X10	
12	025040233	4	ヒラサ"ガ"ネチユウ4	PLAIN WASHER 4	
13	149809000	1	タイラツプL	BEAD BAND (L)	

M. モーター関係/Motor mechanism/Motor/
Mécanisme du moteur/Mecanismo del motor

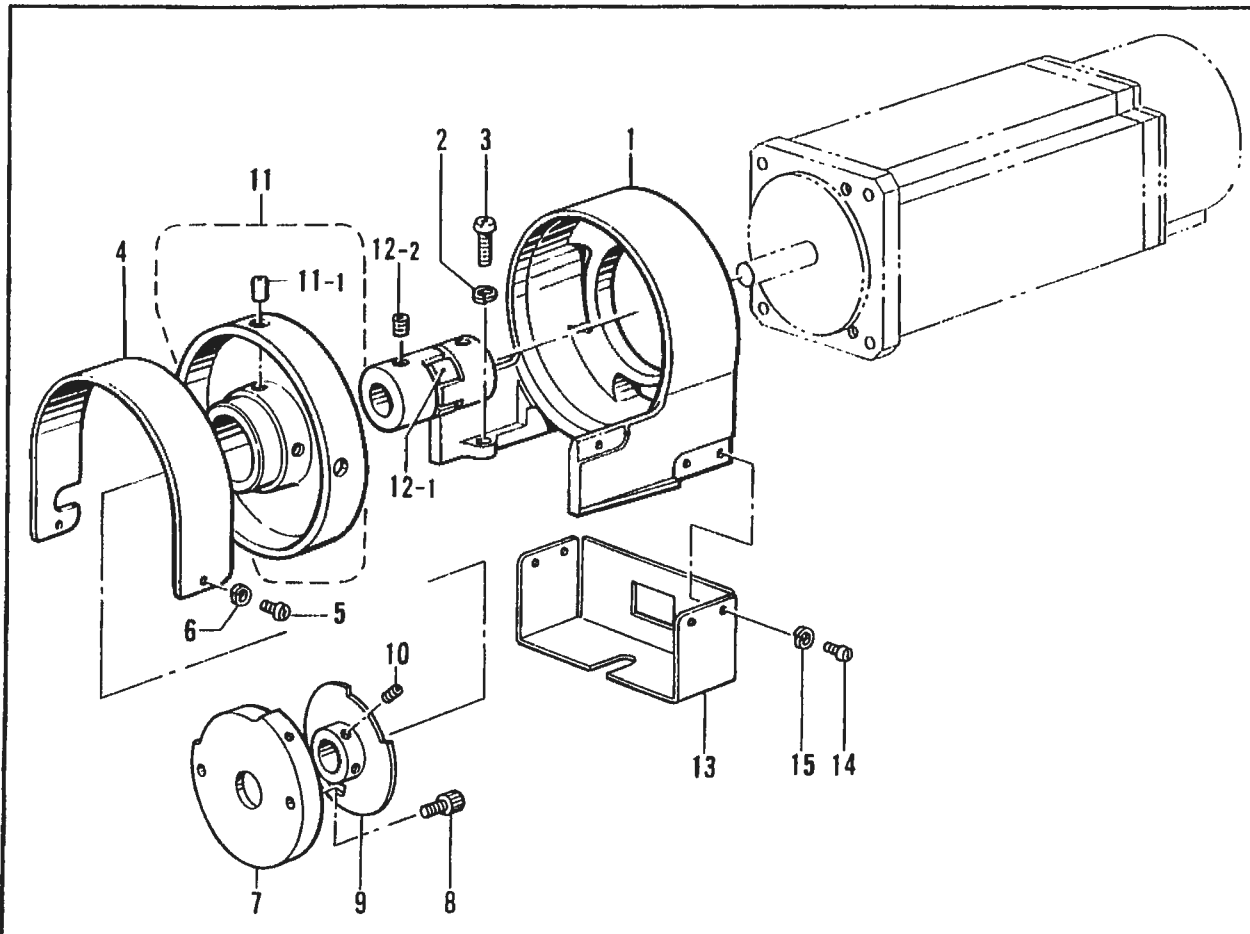

N. 針板関係/Needle plate mechanism/Stichplattenmechanismus/
Mécanisme de plaque à aiguille/Mecanismo de la placa de aguja

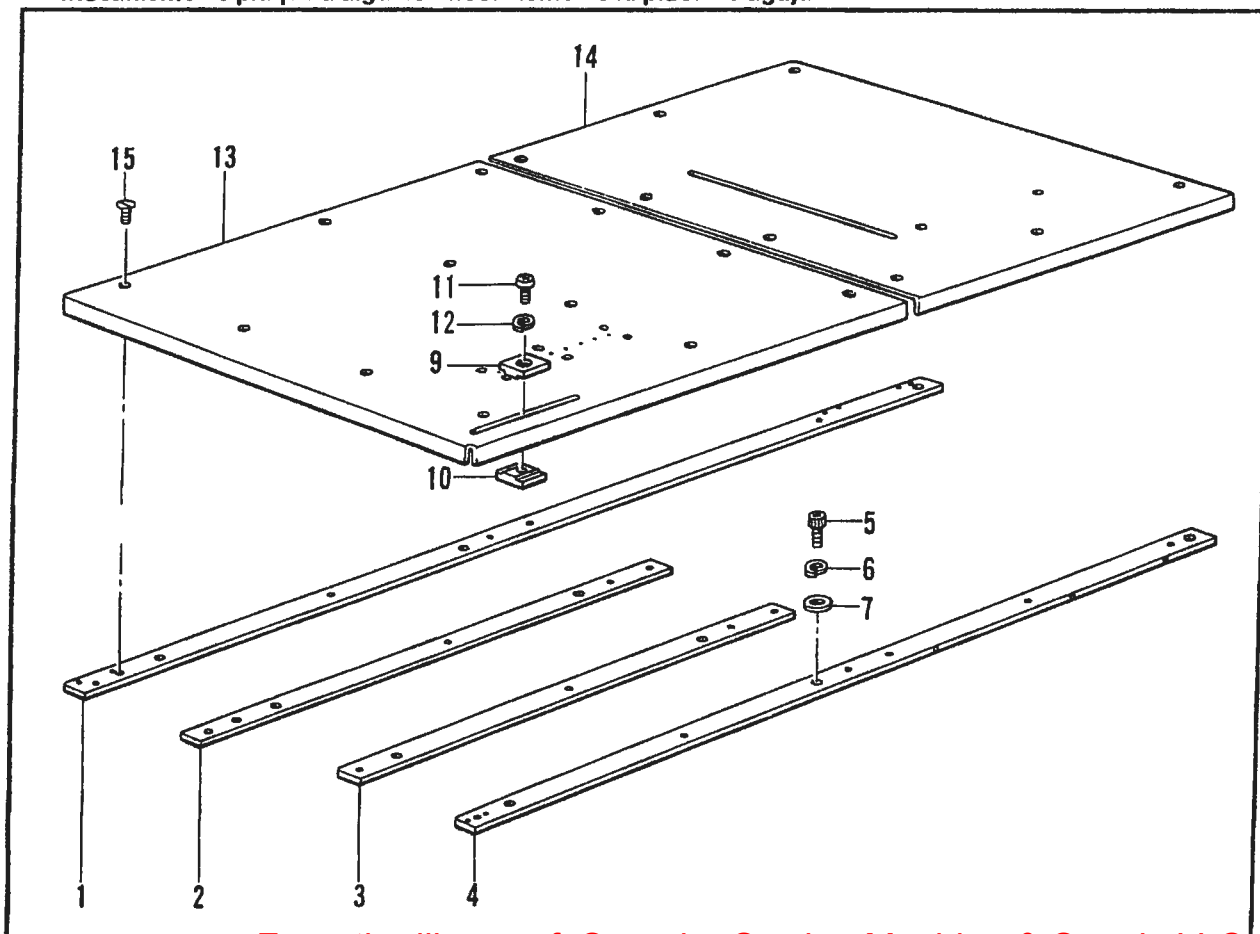

M. モーター関係/Motor mechanism/Motor/
Mécanisme du moteur/Mecanismo del motor

REF NO	CODE	Q'TY	ヒンメイ	NAME OF PARTS	RMKS
1	S11934009	1	DDモータブ"ラケット	DD-MOTOR BRACKET	
2	028060243	2	ハ"ネサ"カ"ネ2-6	SPRING WASHER 2-6	
3	062061606	2	ナヘ"コ6X16	SCREW 6X16	
4	S11935009	1	フ"ーリカハ"ー	PULLEY COVER	
5	062300612	2	ナヘ"コ3X6	SCREW 3X6	
6	028030242	2	ハ"ネサ"カ"ネ2-3	SPRING WASHER 2-3	
7	S11936001	1	センサトメカラー	SENSOR STOP COLLAR	
8	018401022	2	アナホ"ルト4X10	BOLT 4X10	
9	S11937001	1	センサト"グ"クミ	SENSOR DOG ASSEMBLY	
10	014400422	2	アナトメネシ"4X4クホ"ミ	SET SCREW 4X4	
11	S12492009	1	フ"ーリクミ	PULLEY ASSEMBLY	
11 1	014500522	2	アナトメネシ"5クホ"ミ	SET SCREW 5	
12	152593000	1	カツプ"リンク"クミ	COUPLING ASSEMBLY	
12-1	152387000	1	カツプ"リンク"C	COUPLING (C)	
12 2	014770622	4	アナトメネシ"6.35クホ"ミ	SET SCREW 6.35	
13	S11943009	1	カハ"ー	COVER	
14	062300612	4	ナヘ"コ3X6	SCREW 3X6	
15	028030242	4	ハ"ネサ"カ"ネ2-3	SPRING WASHER 2-3	

N. 針板関係/Needle plate mechanism/Stichplattenmechanismus/
Mécanisme de plaque à aiguille/Mecanismo de la placa de aguja

REF.NO.	CODE	Q'TY	ヒンメイ	NAME OF PARTS	RMKS
1	S11961001	1	ハリイタササエ1	NEEDLE PLATE SUPPORT 1	
2	S11962001	1	ハリイタササエ2	NEEDLE PLATE SUPPORT 2	
3	S11963001	1	ハリイタササエ3	NEEDLE PLATE SUPPORT 3	
4	S11964001	1	ハリイタササエ4	NEEDLE PLATE SUPPORT 4	
5	018501222	10	アナホ"ルト5X12	BOLT 5X12	
6	028050242	10	ハ"ネサ"カ"ネ2-5	SPRING WASHER 2-5	
7	025050232	10	ヒラサ"カ"ネチユウ-5	PLAIN WASHER 5	
9	S11966001	1	イチキ"メウエ	POSITIONING UPPER	
10	S11967001	1	イチキ"メシタ	POSITIONING LOWER	
11	062400616	1	ナヘ"コM4X6	SCREW M4X6	
12	028040243	1	ハ"ネサ"カ"ネ2-4	SPRING WASHER 2-4	
13	S11954000	1	ハリイタ"タ"イル	NEEDLE PLATE (L)	
14	S11955000	1	ハリイタ"タ"イル	NEEDLE PLATE (R)	
15	100032003	20	サラネシ"4.37	SCREW 4.37	

P. スタッカー関係/Stacker mechanism/Anhäufung/
Mécanisme de l'empileur/Mecanismo de apilador

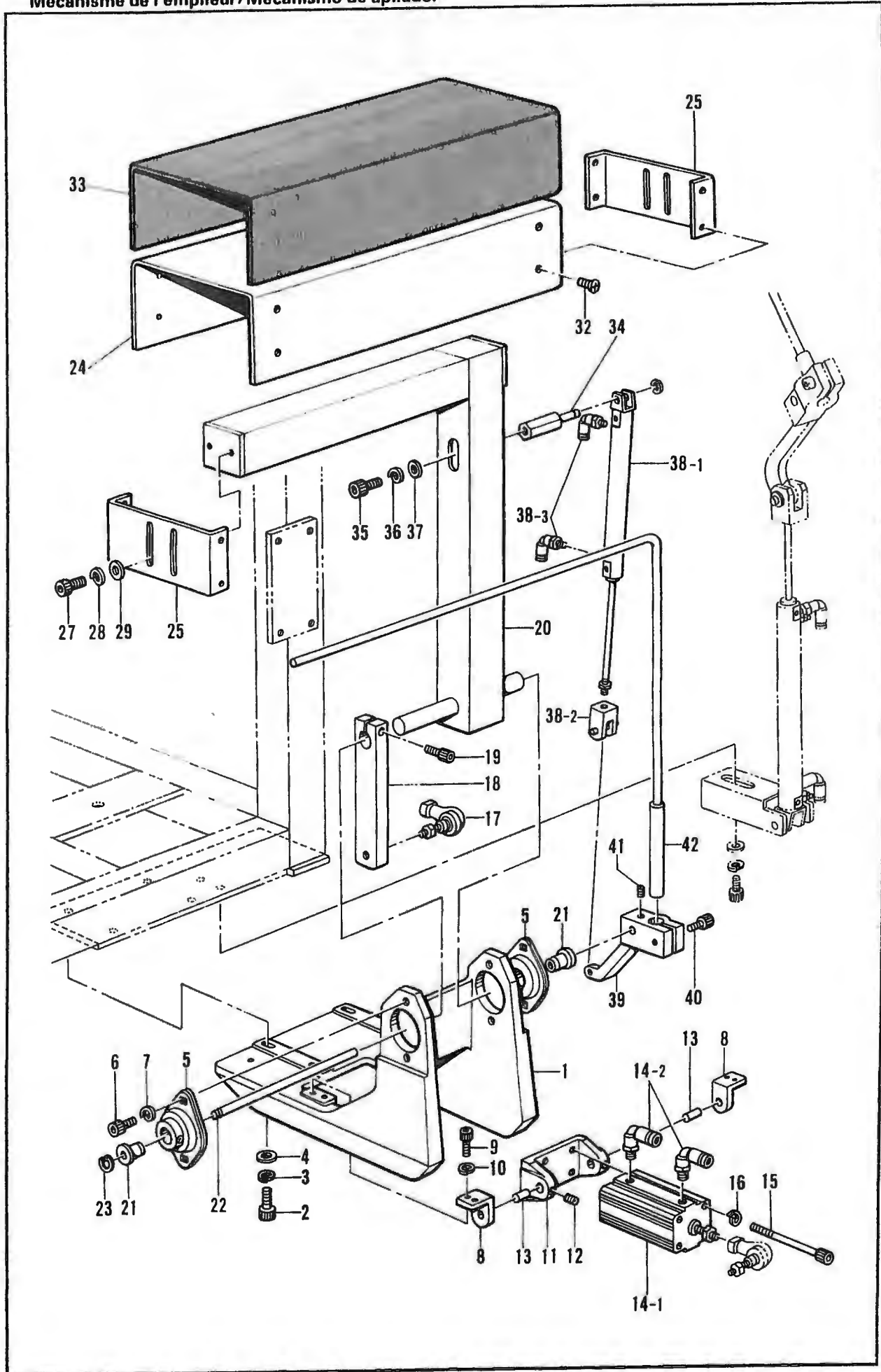

P. スタッカー関係/Stacker mechanism/Anhäufung/
Mécanisme de l'empileur/Mecanismo de apilador

REF NO.	CODE	Q'TY	ヒンメイ	NAME OF PARTS	RMKS
<ヒョウジュンスタッカーヨウ /FOR STANDARD STACKER >					
1	S11968009	1	ベース	BASE	
2	018082522	4	アナボルト8X25	BOLT 8X25	
3	028080242	4	ハネサカネ2-8	SPRING WASHER 2-8	
4	025080232	4	ヒラサカネチユウ 8	PLAIN WASHER 8	
5	S11969000	2	フランジガタユニット2	FRANGE TYPE UNIT 2	
6	018081222	4	アナボルト8X12	BOLT 8X12	
7	028080242	4	ハネサカネ2-8	SPRING WASHER 2-8	
8	S11970009	2	ヒンジ	HINGE	
9	018061422	4	アナボルト6X14	BOLT 6X14	
10	028060242	4	ハネサカネ2-6	SPRING WASHER 2-6	
11	S11971009	1	ナツクル	KNUCKLE	
12	014400522	2	アナクボミ4X5	SET SCREW 4X5	
13	S11972001	2	クレビスピン	CLEVIS PIN	
14	S11973000	1	シリンダ-32X80クミ	CYLINDER 32X80 ASSEMBLY	
14-1	S11974000	1	シリンダ-32X80	CYLINDER 32X80	
14-2	S04909000	2	エルボユニオン	ELBOW UNION	
15	S11975000	4	CQ2ボルトM5X135	CQ2 BOLT M5X135	
16	028050242	4	ハネサカネ2-5	SPRING WASHER 2-5	
17	S11976000	1	リンクボール10	LINK BALL 10	
18	S11977001	1	レバー(3)	LEVER 3	
19	018062522	1	アナボルト6X25	BOLT 6X25	
20	S11978009	1	フレーム	FRAME	
21	S11979000	2	フランジブッシュ1220	FLANGE BUSH 1220	
22	S11980001	1	レバーシャフト	LEVER SHAFT	
23	048120142	1	トメワシクヨウC12	STOP RING C12	
24	S17703000	1	スタッカープレート	STACKER PLATE	
25	S17707009	2	スタッカーブラケット	STACKER BRACKET	
27	018501022	4	アナボルト5X10	BOLT 5X10	
28	028050242	4	ハネサカネ2-5	SPRING WASHER 2-5	
29	025050232	4	ヒラサカネチユウ5	PLAIN WASHER 5	
32	004400702	8	ササネシ4X7	SCREW 4X7	
33	S17704000	1	スタッカーテーブルゴム	STACKER TABLE RUBBER	
34	S11985001	1	クレビスシャフト1	CLEVIS SHAFT 1	
35	018081222	1	アナボルト8X12	BOLT 8X12	
36	028080242	1	ハネサカネ2-8	SPRING WASHER 2-8	
37	025080232	1	ヒラサカネチユウ 8	PLAIN WASHER 8	
38	S11986000	1	シリンダ-20X150Cクミ	CYLINDER 20X150 (C) ASSEMBLY	
38-1	S11987000	1	シリンダ-20X150C	CYLINDER 20X150 (C)	
38-2	S11988000	1	2ヤマナツクルシヨイント2	KNUCKLE JOINT 2	
38-3	S11426000	2	エルボユニオン4M5	ELBOW UNION 4M5	
39	S11989009	1	レバー(1)	LEVER 1	
40	018062522	1	アナボルト6X25	BOLT 6X25	
41	014060632	1	アナトメ6X6クボミ	SET SCREW 6X6	
42	S11990001	1	オサエボウ	PRESSER BAR	

P. スタッカー関係/Stacker mechanism/Anhäufung/
Mécanisme de l'empileur/Mecanismo de apilador

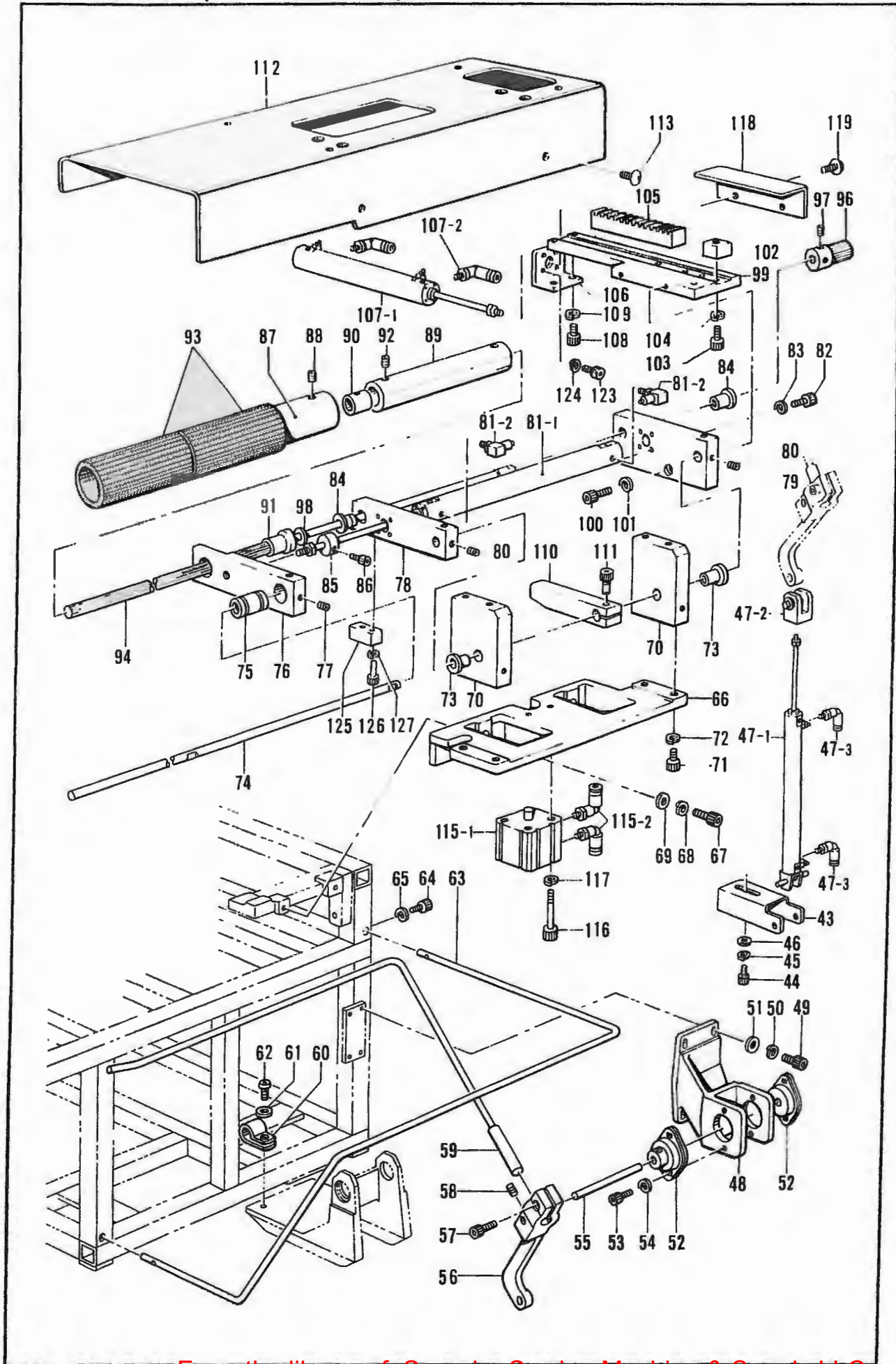

P. スタッカー関係 / Stacker mechanism / Anhäufung /
 Mécanisme de l'empileur / Mecanismo de apilador

REI. NO.	CODE	Q'TY	ヒンメイ	NAME OF PARTS	RMKS
<ヒョウジ ンスタッカー・ワーキングスタッカーヨウ / FOR STANDARD STACKER AND WORKING STACKER >					
43	S11991009	1	スタツカーウケカナク	STACKER SUPPORT METAL FITTING	
44	018061422	2	アナホ"ルト6X14	BOLT 6X14	
45	028060242	2	ハ"ネサ"カ"ネ2-6	SPRING WASHER 2 6	
46	025060237	2	ヒラサ"カ"ネチユウ 6	PLAIN WASHER 6	
47	S11992000	1	シリンダ"-25X200Cクミ	CYLINDER 25X200 (C) ASSEMBLY	
47-1	S11993000	1	シリンダ"-25X200C	CYLINDER 25X200 (C)	
47-2	S11994000	1	2ヤマナツクルシ"ヨイント1	KNUCKLE JOINT 1	
47-3	S11426000	2	エルホ"ユニオン4M5	ELBOW UNION 4M5	
48	S11995009	1	ヘ"-ス(2)	BASE 2	
49	018062022	4	アナホ"ルト6X20	BOLT 6X20	
50	028060242	4	ハ"ネサ"カ"ネ2-6	SPRING WASHER 2-6	
51	025060232	4	ヒラサ"カ"ネチユウ 6	PLAIN WASHER 6	
52	S11996000	2	フランシ"カ"タユニット1	FLANGE TYPE UNIT 1	
53	018061422	4	アナホ"ルト6X14	BOLT 6X14	
54	028060242	4	ハ"ネサ"カ"ネ2-6	SPRING WASHER 2-6	
55	S11997001	1	シャフト	SHAFT	
56	S11998009	1	レハ"- (2)	LEVER 2	
57	018062522	1	アナホ"ルト6X25	BOLT 6X25	
58	014060632	1	アタメ6X6クホ"ミ	SET SCREW 6X6	
59	S11999001	1	キシ"ハライホ"ウ	CLOTH WIPER SHAFT	
60	525907000	1	コート"ホルタ"#9	CORD HOLDER #9	
61	025040233	1	ヒラサ"カ"ネチユウ4	PLAIN WASHER 4	
62	062400806	1	ナヘ"コ4X8	SCREW 4X8	
63	S12042009	1	スタツカー"ガード"	STACKER GUARD	
64	018501222	4	アナホ"ルト5X12	BOLT 5X12	
65	028050242	4	ハ"ネサ"カ"ネ2-5	SPRING WASHER 2-5	
67	018062022	2	アナホ"ルト6X20	BOLT 6X20	
68	028060242	2	ハ"ネサ"カ"ネ2-6	SPRING WASHER 2-6	
69	025060232	2	ヒラサ"カ"ネチユウ 6	PLAIN WASHER 6	
73	S12002000	2	フランシ"フ"ツシユ1012	FLANGE BUSH 1012	
74	S12003000	1	LMシャフト	LM SHAFT	
75	S12004000	1	リニアフ"ツシユ	LINEAR BUSH	
76	S12005001	1	タイプレート	TIE PLATE	
77	014400522	2	アタクホ"ミ4X5	SET SCREW 4X5	
78	S12006000	1	イント"プレートB	END PLATE (B)	
79	S12007000	1	イント"プレートA	END PLATE (A)	
80	014400522	4	アタクホ"ミ4X5	SET SCREW 4X5	
81	S12008000	1	シリンダ"-20X150クミ	CYLINDER 20X150 ASSEMBLY	
81-1	S12009000	1	シリンダ"-20X150	CYLINDER 20X150	
81-2	S12150000	2	ホ"-スエルホ"M-5HL-4	TUBE ELBOW (M-5HL-4)	
82	018401622	8	アナホ"ルト4X16	BOLT 4X16	
83	028040242	8	ハ"ネサ"カ"ネ2-4	SPRING WASHER 2-4	
84	S12010000	2	フランシ"フ"ツシユ1010	FLANGE BUSH 1010	
85	S12011001	1	ストツハ"	STOPPER	
86	018401022	1	アナホ"ルト4X10	BOLT 4X10	
87	S12012000	1	ローラー	ROLLER	
88	014500522	2	アタメネシ"5クホ"ミ	SET SCREW 5	
89	S12013000	1	ローラー"ササエ	ROLLER SUPPORT	
90	S12014000	1	スプラインナツト1	SPLINE NUT 1	
91	S12015000	1	スプラインナツト2	SPLINE NUT 2	
92	014500522	4	アタメネシ"5クホ"ミ	SET SCREW 5	
93	S20789000	2	スリーブ"ロール	SLEEVE ROLL	
94	S17718000	1	スプラインシ"ク	SPLINE SHAFT	
96	S12019001	1	ギ"ヤ	GEAR	
97	014500522	2	アタメネシ"5クホ"ミ	SET SCREW 5	
98	S09027001	1	ヒラサ"カ"ネチユウ10	PLAIN WASHER 10	
99	S12020001	1	ローラー"ガイド"	ROLLER GUIDE	
100	018401622	1	アナホ"ルト4X16	BOLT 4X16	
101	028040242	2	ハ"ネサ"カ"ネ2-4	SPRING WASHER 2-4	
102	S12021001	1	ラツクストツハ"	RACK STOPPER	

P. スタッカー関係 / Stacker mechanism / Anhäufung /
Mécanisme de l'empileur / Mecanismo de apilador

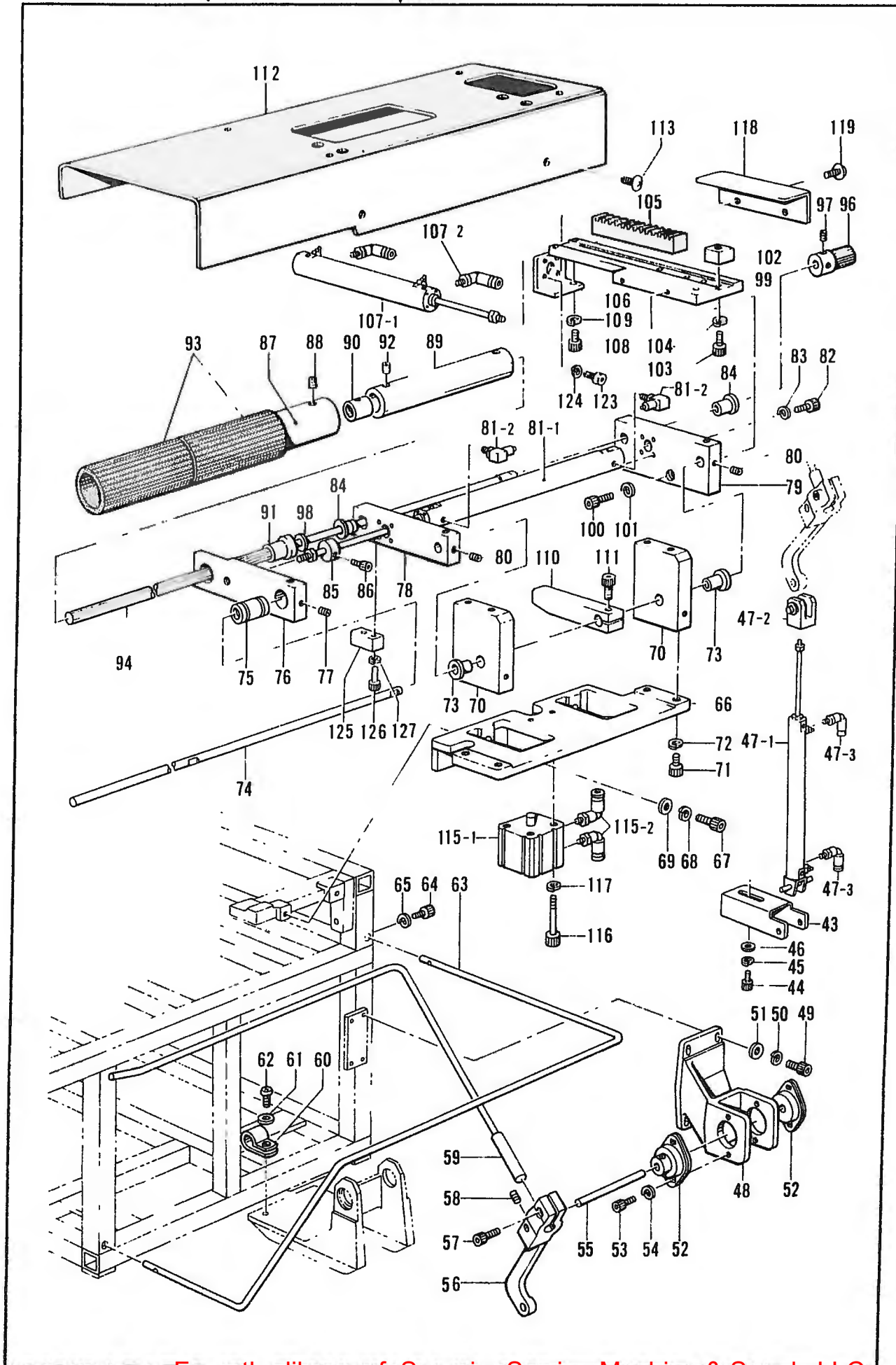

P. スタッカー関係/Stacker mechanism/Anhäufung/
 Mécanisme de l'empileur/Mecanismo de apilador

RII NO	CODE	Q'TY	品名	NAME OF PARTS	RMKS
103	018401622	1	アナボルト4X16	BOLT 4X16	
104	028040242	1	ハネザカネ2-4	SPRING WASHER 2 4	
105	S12022001	1	ラック	RACK	
106	S12023001	1	ローラーブラケット	ROLLER BRACKET	
107	S12024000	1	シリンダー-20X95クミ	CYLINDER 20X95 ASSEMBLY	
107 1	S12025000	1	シリンダー-20X95	CYLINDER 20X95	
107 2	S11426000	2	エルボユニオン4M5	ELBOW UNION 4M5	
108	018401022	7	アナボルト4X10	BOLT 4X10	
109	028040242	6	ハネザカネ2-4	SPRING WASHER 2 4	
110	S12026001	1	ローラーレバー	ROLLER LEVER	
111	018501622	1	アナボルト5X16	BOLT 5X16	
115	S12030000	1	シリンダー-20X15クミ	CYLINDER 20X15 ASSEMBLY	
115 1	S12031000	1	シリンダー-20X15	CYLINDER 20X15	
115 2	S11426000	2	エルボユニオン4M5	ELBOW UNION 4M5	
116	S12276000	2	CQ2ボルトM5X35	CQ2 BOLT M5X35	
117	028050243	2	ハネザカネ2-5	SPRING WASHER 2-5	
118	S12033009	1	ローラーカバー-A	ROLLER COVER (A)	
119	008400604	2	トラスコ4X6	SCREW 4X6	
123	018501022	4	アナボルト5X10	BOLT 5X10	
124	028050242	4	ハネザカネ2-5	SPRING WASHER 2-5	
125	S12277000	1	スペーサー	SPACER	
126	018401022	2	アナボルト4X10	BOLT 4X10	
127	028040242	2	ハネザカネ2-4	SPRING WASHER 2-4	
〈キョウツウピン /FOR COMMON PARTS〉					
66	S12000009	1	ローラーベース	ROLLER BASE	
70	S12001001	2	ローラーシャフトササエ	ROLLER SHAFT SUPPORT	
71	018401222	4	アナボルト4X12	BOLT 4X12	
72	028040242	4	ハネザカネ2-4	SPRING WASHER 2-4	
112	S12029109	1	ローラーカバー-B	ROLLER COVER (B)	
113	008400604	6	トラスコ4X6	SCREW 4X6	

P. スタッカー関係/Stacker mechanism/Anhäufung/
 Mécanisme de l'empileur/Mecanismo de apilador

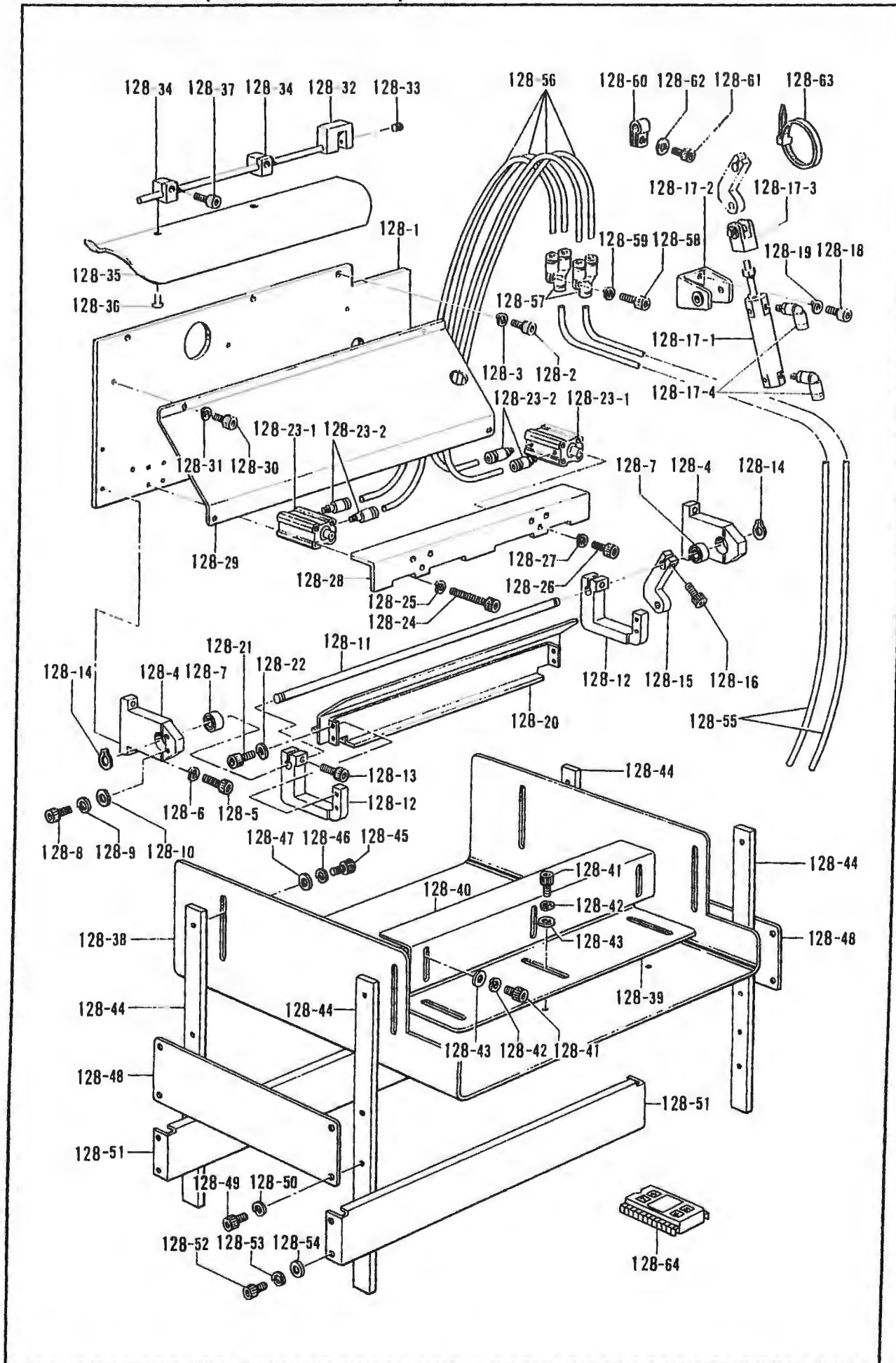

P. スタッカー関係/Stacker mechanism/Anhäufung/
 Mécanisme de l'empileur/Mecanismo de apilador

RLI NO	CODF	Q'TY	ヒンメイ	NAME OF PARTS	RMKS
<コクナイヨウ、オプション>					
128	*	1	スタッカー(WORK)クミ	
128 1	S14462009	1	トリツケイタ	
128 2	018401027	6	アナホ"ルト4X10	
128 3	028040242	6	ハ"ネサ"カ"ネ2-4	
128 4	S14463009	2	ヘ"アリング"ササエ	
128 5	018501622	4	アナホ"ルト5X16	
128 6	028050747	4	ハ"ネサ"カ"ネ2-5	
128 7	S12078000	2	フカミソ"タマジ"クウケ?	
128 8	018400832	4	アナホ"ルト4X8	
128 9	028040242	4	ハ"ネサ"カ"ネ2-4	
128 10	025040237	4	ヒラサ"カ"ネチユウ4	
128 11	S14464001	1	LMシャフト12	
128 12	S14465009	2	レハ"ーB	
128 13	018502022	2	アナホ"ルト5X20	
128 14	048120142	2	トメワ"クヨウC12	
128 15	S14466001	1	レハ"ーA	
128 16	018502022	1	アナホ"ルト5X20	
128 17	S14468000	1	シリンタ"-25X70クミ	
128 17 1	S14469000	1	シリンタ"-25X70	
128 17 2	S12139000	1	ヨウト"ウウケカナク"1	
128 17 3	S11994000	1	2ヤマナツクルシ"ヨイント1	
128 17 4	S11426000	2	エルホ"ユニオン4M5	
128-18	018500822	4	アナホ"ルト5X8	
128 19	028050242	4	ハ"ネサ"カ"ネ2-5	
128 20	S14470000	1	スヘ"リイタ	
128 21	018500822	4	アナホ"ルト5X8	
128 22	028050242	4	ハ"ネサ"カ"ネ2-5	
128 23	S14471000	2	シリンタ"-20X40クミ	
128 23-1	S14472000	2	ウスカ"タシリンタ"20X40	
128-23-2	S04905000	4	ハーフユニオン	
128-24	S14473000	8	CQ2ホ"ルトM5X60	
128-25	028050243	16	ハ"ネサ"カ"ネ2-5	
128 26	018501622	2	アナホ"ルト5X16	
128-27	028050242	2	ハ"ネサ"カ"ネ2-5	
128-28	S14475009	1	プレスイタ	
128-29	S14477000	1	スヘ"リイタA	
128-30	062400806	5	ナヘ"コ4X8	
128-31	028040243	5	ハ"ネサ"カ"ネ2-4	
128-32	S14478001	1	カ"イト"イタササエ	
128-33	014500522	2	アナトメネジ"5クホ"ミ	
128-34	S14479001	2	カ"イト"イタコチイ	
128-35	S14480000	1	カ"イト"イタ	
128-36	003400804	2	サラネジ"4X8	
128-37	018401622	2	アナホ"ルト4X16	
128-38	S14481009	1	ミゴ"ロウケ	
128-39	S14482009	1	マクラシタ	
128-40	S14483009	1	マクラウエ	
128-41	018400832	6	アナホ"ルト4X8	
128-42	028040243	6	ハ"ネサ"カ"ネ2-4	
128-43	025040233	6	ヒラサ"カ"ネチユウ4	
128-44	S14484009	4	スタント"	
128-45	018501022	4	アナホ"ルト5X10	
128-46	028050242	4	ハ"ネサ"カ"ネ2-5	
128-47	025050232	4	ヒラサ"カ"ネチユウ-5	
128-48	S14485009	2	レンケツイタ	
128-49	018501022	8	アナホ"ルト5X10	
128-50	028050242	8	ハ"ネサ"カ"ネ2-5	
128-51	S14486009	2	コチイタ	
128-52	018501022	8	アナホ"ルト5X10	
128-53	028050242	8	ハ"ネサ"カ"ネ2-5	
128-54	025050232	8	ヒラサ"カ"ネチユウ-5	

P. スタッカー関係 / Stacker mechanism / Anhäufung /
Mécanisme de l'empileur / Mecanismo de apilador

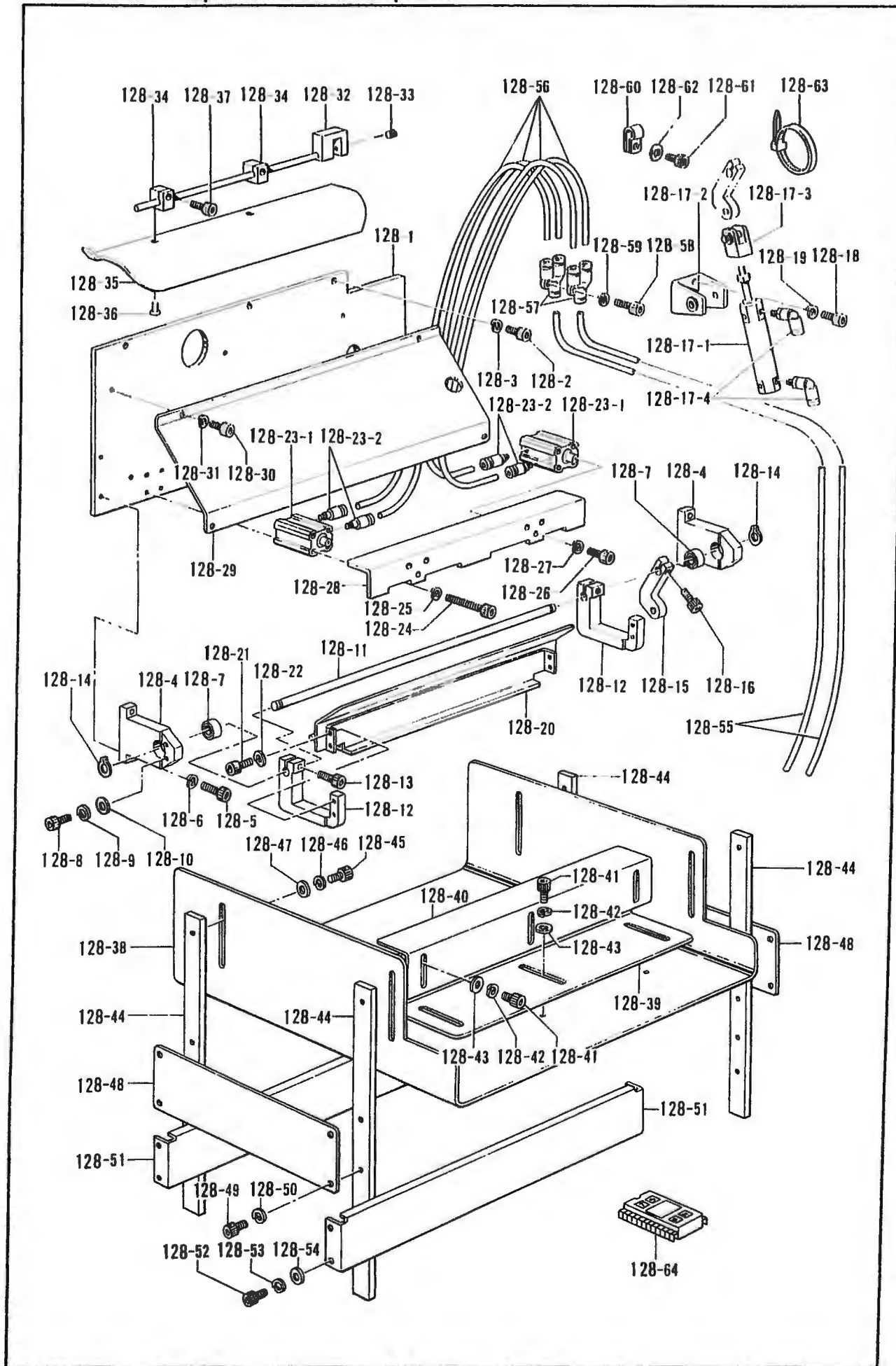

P. スタッカー関係/Stacker mechanism/Anhäufung/
 Mécanisme de l'empileur/Mecanismo de apilador

RFI NO	CODE	Q'TY	品名	NAME OF PARTS	RMKS
128 55	S12195000	2	エアホース4X2.5-19	-----	
128 56	S12183000	4	エアホース4X2.5-7	-----	
128 57	S12104000	2	ユニオンワイ4	-----	
128 58	018402522	1	アナボルト4X25	-----	
128 59	028040242	1	ハネサカネ2-4	-----	
128 60	146202000	2	ナイロンクリップ6N	-----	
128 61	062400806	2	ナベコ4X8	-----	
128 62	025040233	2	ヒラサカネチユウ4	-----	
128 63	S04159000	3	ハント1M	-----	
128 64	S12057100	1	PROM750-2ワーク	-----	

U. 駆動部・送り関係/Drive, feed mechanism/Transporvorrichtung/
 Mécanisme d'alimentation, entraînement/Mecanismo de la alimentación, mando

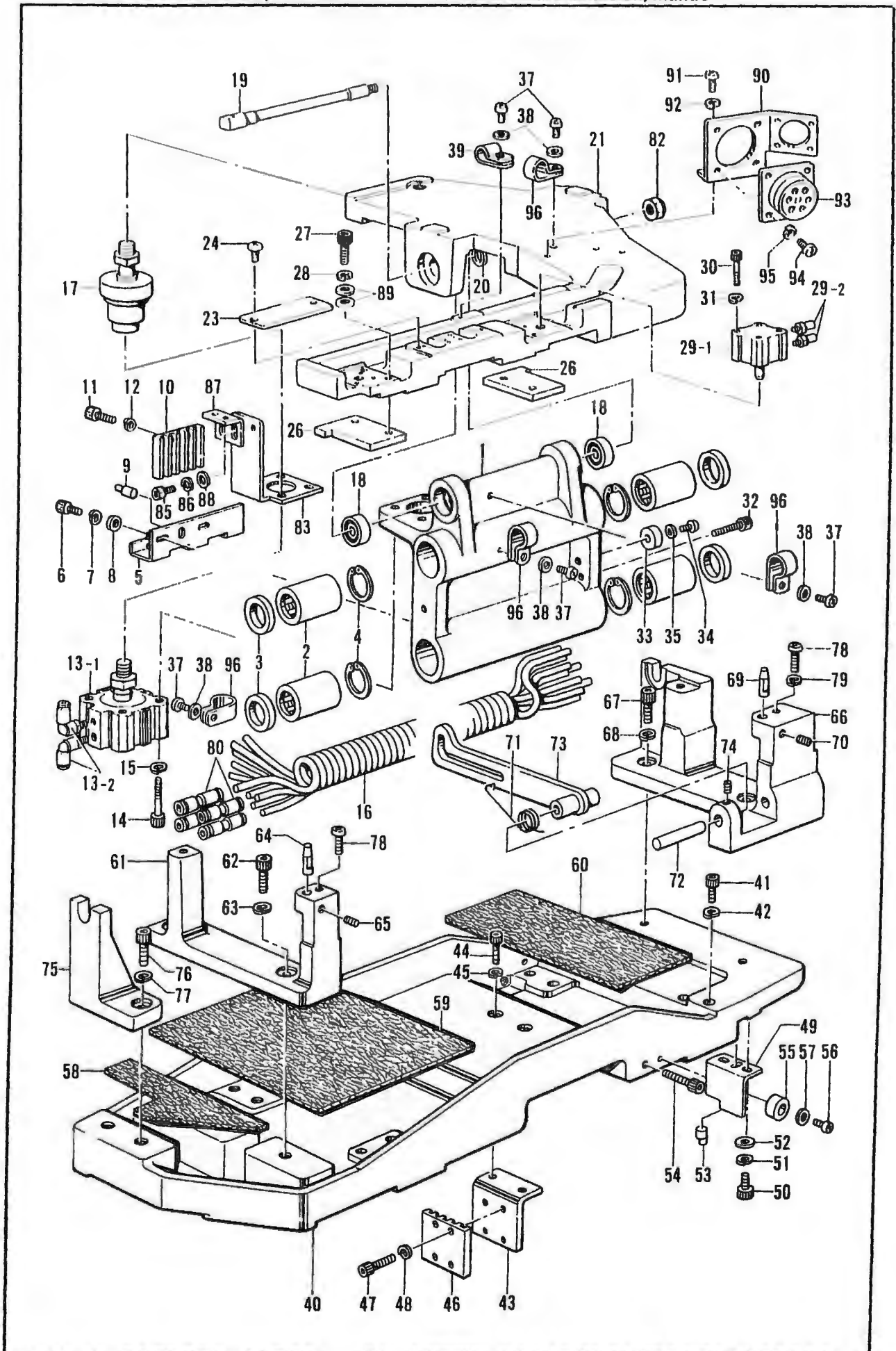

Q. 駆動側・送り関係/Drive, feed mechanism/Transporvorrichtung/
Mécánisme d'alimentation, entraînement/Mecanismo de la alimentación, mando

REF.NO.	CODE	Q'TY	ヒンメイ	NAME OF PARTS	RMKS
1	S17719009	1	オサエサエ	PRESSER SUPPORT	
2	S12035000	4	リニアボールベアリング	LINEAR BALL BEARING	
3	S12036000	4	クミアフセシール	COMBINATION SEAL	
4	048350242	4	トメワアナヨウC35	STOP RING C35	
5	S17706001	1	スリットB	SLIT (B)	
6	018400832	2	アナボルト4X8	BOLT 4X8	
7	028040242	2	ハネサカネ2-4	SPRING WASHER 2-4	
8	025040232	2	ヒラサカネチユウ4	PLAIN WASHER 4	
9	S12038001	1	スリットピン	PIN	
10	S12039001	1	ベルトホシイタB	BELT HOLD PLATE (B)	
11	018501622	4	アナボルト5X16	BOLT 5X16	
12	028050242	4	ハネサカネ2-5	SPRING WASHER 2-5	
13	S17725000	1	シリンタ-40X5クミ	CYLINDER 40X5 ASSEMBLY	
13-1	S17726000	1	シリンタ-40X5	CYLINDER 40X5	
13 2	S04909000	2	エルボユニオン	ELBOW UNION	
14	S19553000	4	CQ2ボルトM5X40	CQ2 BOLT M5X40	
15	028050243	4	ハネサカネ2-5	SPRING WASHER 2-5	
16	S17727000	1	コイルチューブ	COIL TUBE	
17	S12044000	1	フローティングジョイント	FLOATING JOINT	
18	S12045000	2	アンギユラタマシクウゲ1	ANGULAR BALL BEARING 1	
19	S15538001	1	ポケットオサエシク	POCKET PRESSER SHAFT	
20	S15539001	1	カラ-2-15	COLLAR 2-15	
21	S17716009	1	オサエ	SEWING CLAMP SUPPORT	
23	S17717009	1	オサエカバー	COVER	
24	008400604	2	トラスコ4X6	SCREW 4X6	
26	S12050001	2	ブロックササエ	BLOCK SUPPORT	
27	018502022	4	アナボルト5X20	BOLT 5X20	
28	028050242	4	ハネサカネ2-5	SPRING WASHER 2-5	
29	S12051000	2	ロックシリンタ-クミA	LOCK CYLINDER ASSEMBLY (A)	
29-1	S12052000	2	ロックシリンタ-	LOCK CYLINDER	
29-2	S11433000	4	ホースニツフル4M5	HOSE NIPPLE 4M5	
30	S12053000	8	CQ2ボルトM3X25	CQ2 BOLT M3X25	
31	028030243	8	ハネサカネ2-3	SPRING WASHER 2-3	
32	018503022	1	アナボルト5X30	BOLT 5X30	
33	S12054000	2	クッション	CUSHION	
34	062400806	2	ナヘコ4X8	SCREW 4X8	
35	025040233	2	ヒラサカネチユウ4	PLAIN WASHER 4	
37	062400806	5	ナヘコ4X8	SCREW 4X8	
38	025040233	5	ヒラサカネチユウ4	PLAIN WASHER 4	
39	149287000	1	ナイロンクランプ7N	NYLON CLAMP 7N	
40	S15540000	1	ミシンササエ	HEAD SUPPORT	
41	018401622	16	アナボルト4X16	BOLT 4X16	
42	028040242	16	ハネサカネ2-4	SPRING WASHER 2-4	
43	S12056001	1	ベルトホシイタA	BELT HOLD PLATE (A)	
44	018502022	2	アナボルト5X20	BOLT 5X20	
45	028050242	2	ハネサカネ2-5	SPRING WASHER 2-5	
46	S12039001	1	ベルトホシイタB	BELT HOLD PLATE (B)	
47	018501622	4	アナボルト5X16	BOLT 5X16	
48	028050242	4	ハネサカネ2-5	SPRING WASHER 2-5	
49	S15541001	1	スリットA	SLIT (A)	
50	018400832	2	アナボルト4X8	BOLT 4X8	
51	028040242	2	ハネサカネ2-4	SPRING WASHER 2-4	
52	025040232	2	ヒラサカネチユウ4	PLAIN WASHER 4	
53	S12038001	1	スリットピン	PIN	
54	018502522	1	アナボルト5X25	BOLT 5X25	
55	S12054000	2	クッション	CUSHION	
56	062400806	2	ナヘコ4X8	SCREW 4X8	
57	025040232	2	ヒラサカネチユウ4	PLAIN WASHER 4	
58	S12268000	1	フェルトL	FELT (L)	
59	S12269000	1	フェルトM	FELT (M)	
60	S12270000	1	フェルトR	FELT (R)	
61	S12059009	1	ミシンウケダライ	HEAD SUPPORT BASE (L)	

Q. 駆動部・送り関係 / Drive, feed mechanism / Transportvorrichtung /
Mécánisme d'alimentation, entraînement / Mecanismo de la alimentación, mando

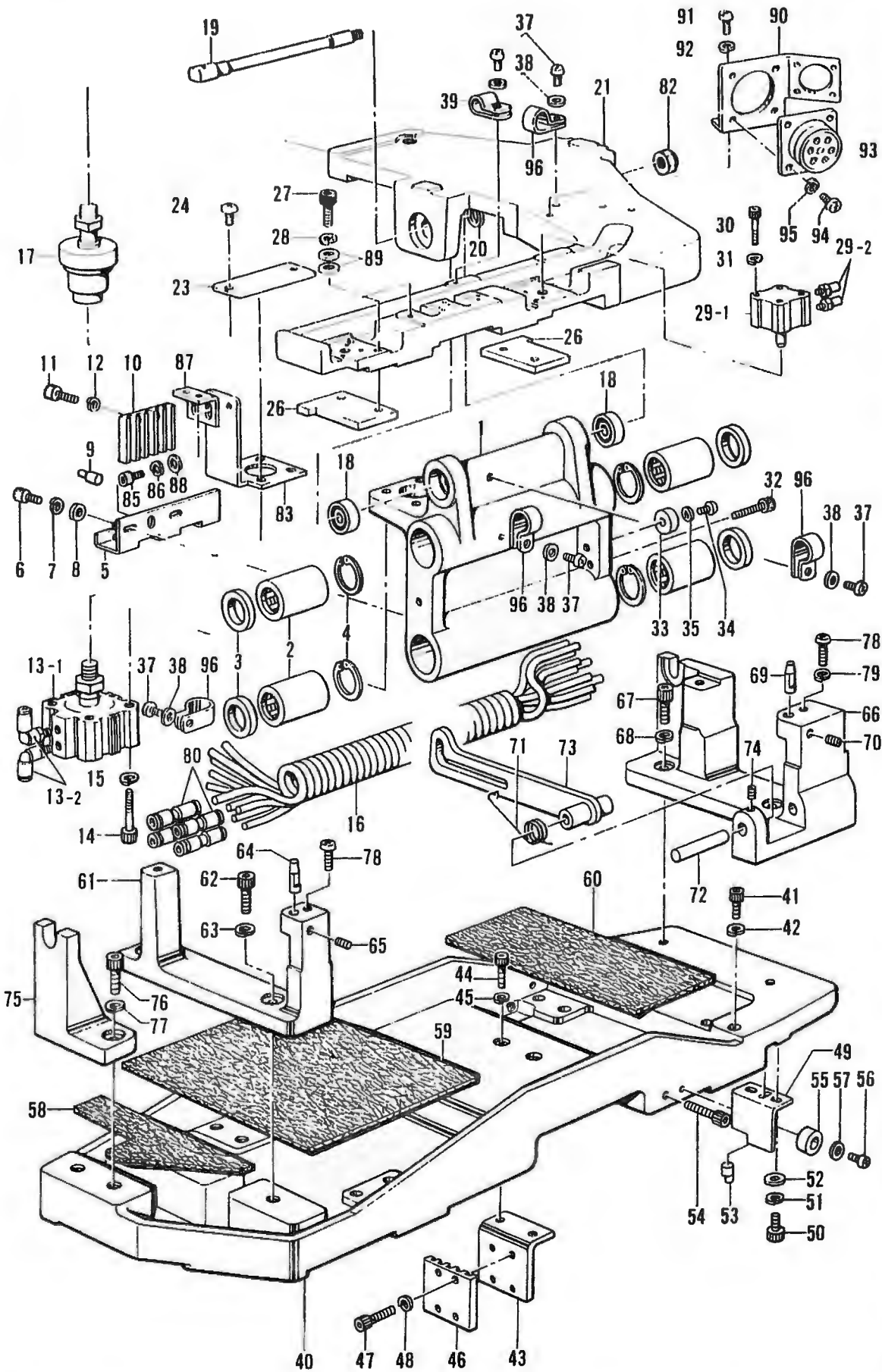

U. 駆動部・送り関係/Drive, feed mechanism/Transporvorrichtung/
 Mécanisme d'alimentation, entraînement/Mecanismo de la alimentación, mando

REF NO.	CODE	Q'TY	品名	NAME OF PARTS	RMKS
62	018082022	2	アナボ"ルト8X20	BOLT 8X20	
63	028080242	2	ハ"ネサ"カ"ネ2-8	SPRING WASHER 2 8	
64	S12060001	1	イチキ"メピン	POSITIONING PIN	
65	014500522	1	アナトメネシ"5クホ"ミ	SET SCREW 5	
66	S12061009	1	ミシンウケタ"イR	HEAD SUPPORT (R)	
67	018082022	2	アナボ"ルト8X20	BOLT 8X20	
68	028080242	2	ハ"ネサ"カ"ネ2-8	SPRING WASHER 2-8	
69	S12060001	1	イチキ"メピン	POSITIONING PIN	
70	014500522	1	アナトメネシ"5クホ"ミ	SET SCREW 5	
71	152859001	1	トウフ"ササエレハ"ーハ"ネ	SPRING	
72	152858001	1	トウフ"ササエレハ"ー"ン"ク	HEAD SUPPORT LEVER SHAFT	
73	152857001	1	トウフ"ササエレハ"ー	HEAD SUPPORT LEVER	
74	014400522	1	アナクホ"ミ4X5	SET SCREW 4X5	
75	S12062009	1	トウフ"ウケ	HEAD HOLDER	
76	018082022	2	アナボ"ルト8X20	BOLT 8X20	
77	028080242	2	ハ"ネサ"カ"ネ2-8	SPRING WASHER 2-8	
78	062501202	4	ナヘ"コM5X12	SCREW M5X12	
79	028050242	2	ハ"ネサ"カ"ネ2-5	SPRING WASHER 2-5	
80	S04587000	8	ストレートツキ"テ	STRAIGHT JOINT	
82	S15545000	1	UナットM8P1	U-NUT M8P1	
83	S17724001	1	センサーリツケイタシタ	SENSOR SET PLATE LOWER	
85	018400832	2	アナボ"ルト4X8	BOLT 4X8	
86	028040242	2	ハ"ネサ"カ"ネ2-4	SPRING WASHER 2-4	
87	S15551001	1	センサーリツケイタウエ	SENSOR SET PLATE UPPER	
88	025040232	2	ヒラサ"カ"ネチユウ4	PLAIN WASHER 4	
89	113431002	8	サ"カ"ネ	WASHER	
90	S19066001	1	マルチコネクタートリツケ	MULTI CONNECTOR SET PLATE	
91	062401006	2	ナヘ"コ4X10	SCREW 4X10	
92	028040243	2	ハ"ネサ"カ"ネ2-4	SPRING WASHER 2-4	
93	S19550000	1	マルチコネクタ-6S	MULTI CONNECTOR (6S)	
94	062400812	4	ナヘ"コ4X8	SCREW 4X8	
95	028040242	4	ハ"ネサ"カ"ネ2-4	SPRING WASHER 2-4	
96	554482000	4	コード"ホルタ"12N	CORD HOLDER 12N	

K. 送り案内機構 / Feed guide mechanism / Transportführung /
 Mécanisme du guide de l'entraînement / Mecanismo de la guía de alimentación

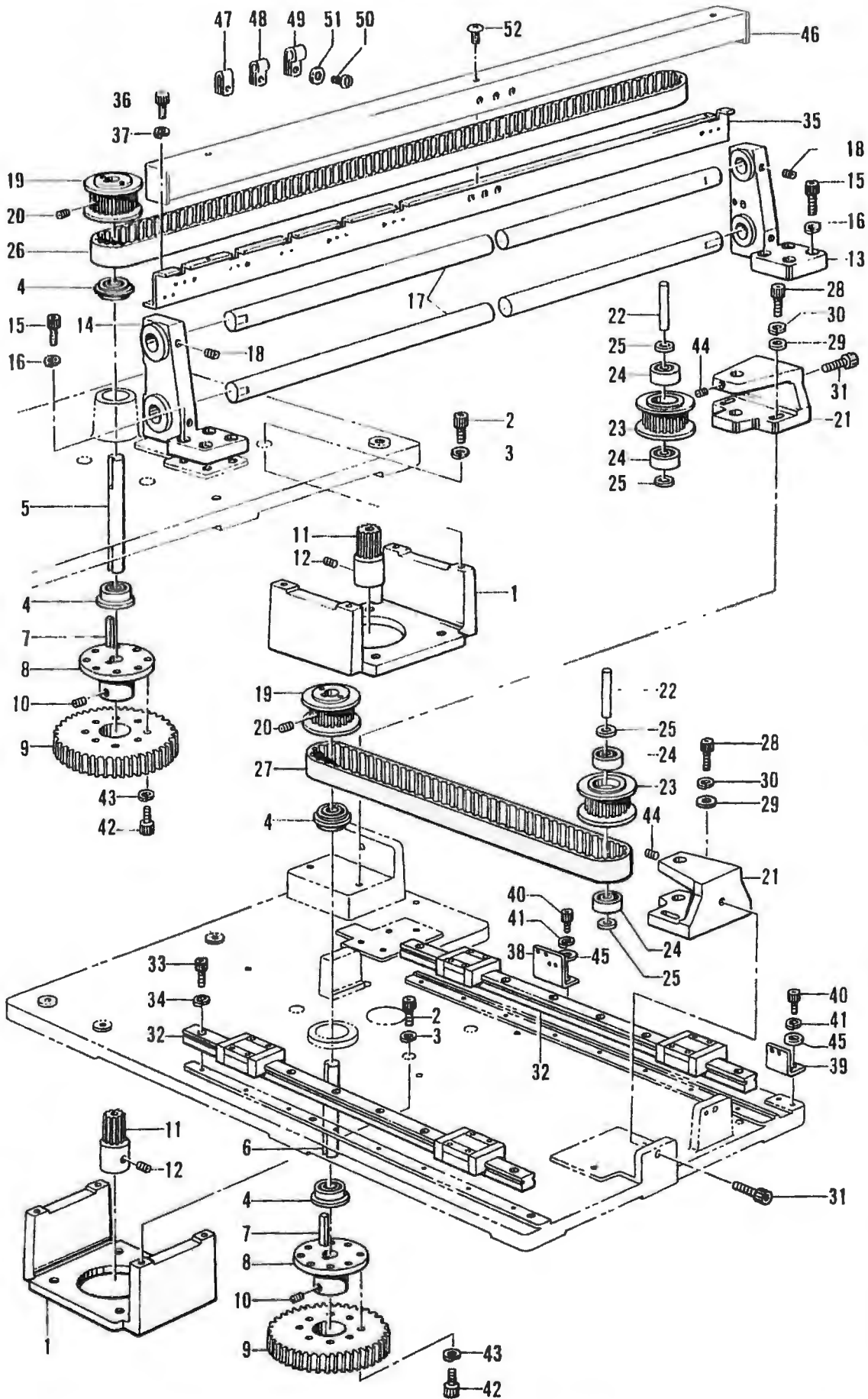

R. 送り案内関係/Feed guide mechanism/Transportführung/
 Mécanisme du guide de l'entraînement/Mecanismo de la guía de alimentación

RLF NO	CODE	Q'TY	品名	NAME OF PARTS	RMKS
1	S12063009	2	モーターササエ	MOTOR SUPPORT	
2	018062022	8	アナボ"ルト6X20	BOLT 6X20	
3	028060242	8	ハ"ネサ"カ"ネ2-6	SPRING WASHER 2-6	
4	S12064000	4	フカミソ"タマシ"クウケ1	DEEP GROOVE BALL BEARING 1	
5	S12065000	1	プーリーシ"クA	PULLEY SHAFT (A)	
6	S12066000	1	プーリーシ"クB	PULLEY SHAFT (B)	
7	S12067000	4	キー	KEY	
8	S12068001	2	ギ"ヤササエ	GEAR SUPPORT	
9	S12069000	2	ナイロンギ"ヤ	NYLON GEAR	
10	014060632	2	アナトメ6X6クホ"ミ	SET SCREW 6X6	
11	S12070000	2	ギ"ヤ	GEAR	
12	014060632	4	アナトメ6X6クホ"ミ	SET SCREW 6X6	
13	S12071009	1	シャフトササエミキ"	SHAFT SUPPORT RIGHT	
14	S12072009	1	シャフトササエヒタ"リ	SHAFT SUPPORT LEFT	
15	018062522	8	アナボ"ルト6X25	BOLT 6X25	
16	028060242	8	ハ"ネサ"カ"ネ2-6	SPRING WASHER 2-6	
17	S12073000	2	LMシャフト25	LM SHAFT 25	
18	014061032	4	アナトメ6X10クホ"ミ	SET SCREW 6X10	
19	S12074000	2	プーリーB	PULLEY (B)	
20	014060632	2	アナトメ6X6クホ"ミ	SET SCREW 6X6	
21	S12075009	2	プーリーササエA	PULLEY SUPPORT (A)	
22	S12076000	2	プーリーシ"クD	PULLEY SHAFT (D)	
23	S12077000	2	プーリーA	PULLEY (A)	
24	S12078000	4	フカミソ"タマシ"クウケ2	DEEP GROOVE BALL BEARING 2	
25	S12079000	4	カラ-2	COLLAR 2	
26	S12080000	1	タイミンク"ベルトA	TIMING BELT (A)	
27	S12081000	1	タイミンク"ベルトB	TIMING BELT (B)	
28	018062022	4	アナボ"ルト6X20	BOLT 6X20	
29	025060232	4	ヒラサ"カ"ネチユウ 6	PLAIN WASHER 6	
30	028060242	4	ハ"ネサ"カ"ネ2-6	SPRING WASHER 2-6	
31	018063022	2	アナボ"ルト6X30	BOLT 6X30	
32	S12082000	2	リニアガイド"	LINEAR GUIDE	
33	018401622	16	アナボ"ルト4X16	BOLT 4X16	
34	028040242	16	ハ"ネサ"カ"ネ2-4	SPRING WASHER 2-4	
35	S17702001	1	カバーササエ	COVER SUPPORT	
36	018400832	3	アナボ"ルト4X8	BOLT 4X8	
37	028040242	3	ハ"ネサ"カ"ネ2-4	SPRING WASHER 2-4	
38	S12084001	1	フォトリツケイタA	PHOTO SENSOR SET PLATE (A)	
39	S12085001	1	フォトリツケイタB	PHOTO SENSOR SET PLATE (B)	
40	018400832	4	アナボ"ルト4X8	BOLT 4X8	
41	028040242	4	ハ"ネサ"カ"ネ2-4	SPRING WASHER 2-4	
42	018501622	16	アナボ"ルト5X16	BOLT 5X16	
43	028050242	16	ハ"ネサ"カ"ネ2-5	SPRING WASHER 2-5	
44	014400522	2	アナクホ"ミ4X5	SET SCREW 4X5	
45	025040232	4	ヒラサ"カ"ネチユウ4	PLAIN WASHER 4	
46	S17705001	1	センサーカバー	SENSOR COVER	
47	S10243000	2	ナイロンクランプ"NK-3N	CORD HOLDER NK-3N	
48	149547000	2	コード"オサエ 4N	CORD HOLDER 4N	
49	S00480000	1	コード"ホルタ"5N	CORD HOLDER 5N	
50	062400806	5	ナ"ヘ"コ4X8	SCREW 4X8	
51	025040233	5	ヒラサ"カ"ネチユウ4	PLAIN WASHER 4	
52	008400604	3	+トラスコ4X6	SCREW 4X6	

S. 折曲メカニズム (特別注文部品)/Folding margin mechanism (Option parts)/Faltungsvorrichtung (Sonderzubehör)/
 Mécanisme de marge d'ourlet (Pièces en option)/Mecanismo de margen de plegado (Piezas a opción)

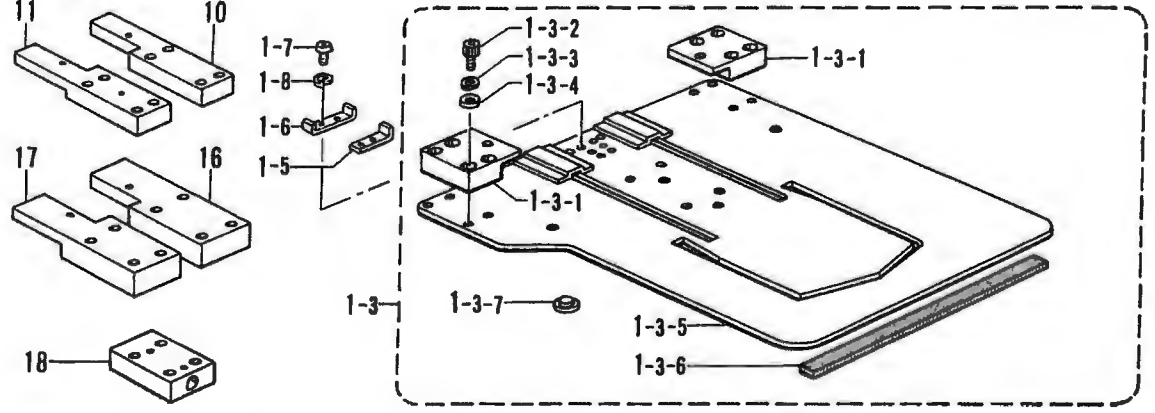
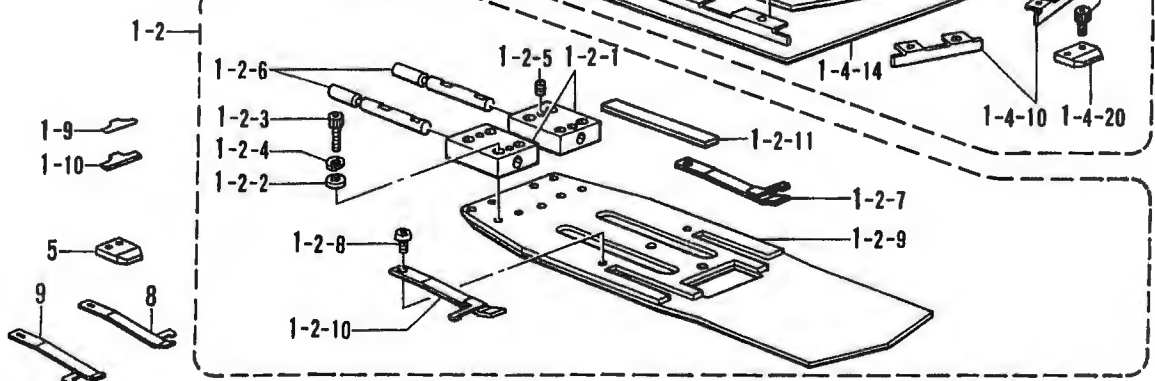
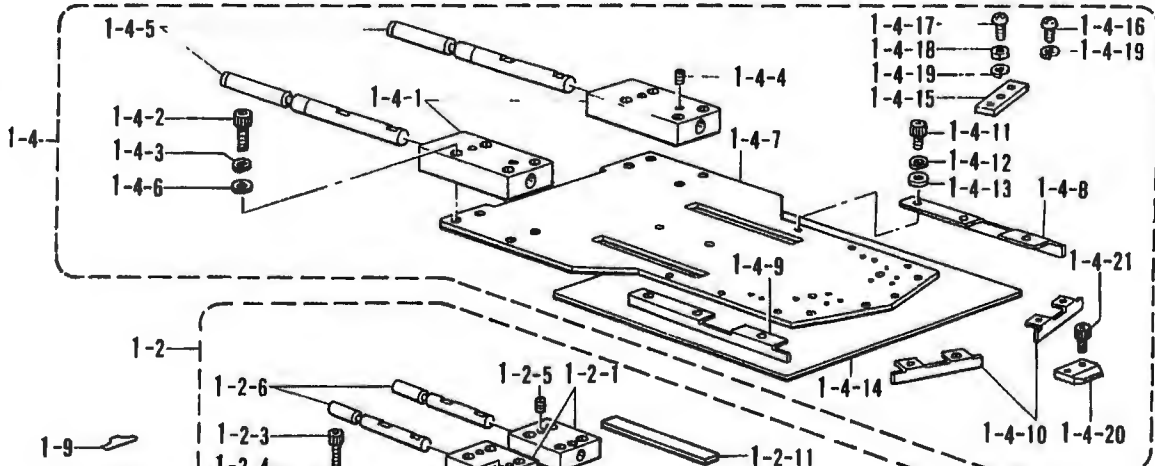
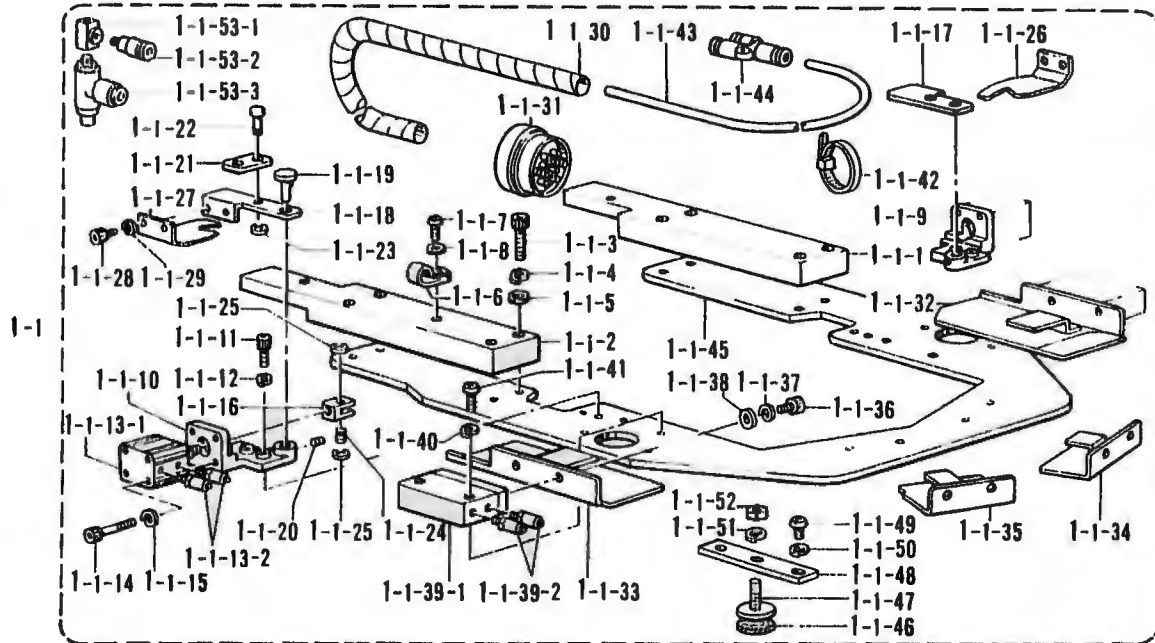

S. 折曲ゲ関係 (特別注文部品)/Folding margin mechanism (Option parts)/Faltungsvorrichtung (Sonderzubehör)/
 Mécanisme de marge d'ourlet (Pièces en option)/Mecanismo de margen de plegado (Piezas a opción)

RI F NO	CODE	Q'TY	ヒンメイ	NAME OF PARTS	RMKS
1	S12283	1	オリキクミ-3カク	FOLDING GROUP ASSEMBLY (TRIANGLE)	
1 1	S12284	1	オリササエクミ-3カク	FOLDING CLAMP ASSEMBLY (TRIANGLE)	
1 1 1	S12086001	1	コネクトフ"ロツクR	CONNECT BLOCK (R)	
1 1 2	S12087001	1	コネクトフ"ロツクL	CONNECT BLOCK (L)	
1 1 3	018502522	8	アナホ"ルト5X25	BOLT 5X25	
1 1 4	028050242	8	ハ"ネサ"ガ"ネ2-5	SPRING WASHER 2-5	
1-1 5	025050232	8	ヒラサ"ガ"ネチユウ-5	PLAIN WASHER 5	
1 1 6	525907000	1	コート"ホルタ"#9	CORD HOLDER #9	
1 1 7	062401006	1	ナヘ"コ4X10	SCREW 4X10	
1 1 8	025040233	1	ヒラサ"ガ"ネチユウ4	PLAIN WASHER 4	
1 1 9	S12088009	1	レハ"-ヘ"-スR	LEVER BASE (R)	
1 1 10	S12089009	1	レハ"-ヘ"-スL	LEVER BASE (L)	
1 1 11	018401222	4	アナホ"ルト4X12	BOLT 4X12	
1 1 12	028040242	4	ハ"ネサ"ガ"ネ2-4	SPRING WASHER 2-4	
1-1 13	S12090000	2	シリンダ"-12X10クミ	CYLINDER 12X10 ASSEMBLY	
1 1 13 1	S12091000	2	シリンダ"-12X10	CYLINDER 12X10	
1-1 13-2	S11433000	4	ホースニツフ"ル4M5	HOSE NIPPLE 4M5	
1 1 14	S12092000	8	CQ2ホ"ルトM3X30	CQ2 BOLT M3X30	
1 1-15	028030243	8	ハ"ネサ"ガ"ネ2-3	SPRING WASHER 2-3	
1-1 16	S12093001	2	ナツクル	KNUCKLE	
1-1 17	S12094001	1	ヒンジ"R	HINGE (R)	
1-1 18	S12095001	1	ヒンジ"L	HINGE (L)	
1-1 19	S12096001	2	ヒンジ"ピン	PIN	
1-1 20	014400522	2	アナホ"ミ4X5	SET SCREW 4X5	
1-1 21	S12097001	2	タイフ"レート	TIE PLATE	
1-1 22	S12098001	2	ピン	PIN	
1-1 23	048050342	2	トメフE5	STOP RING E5	
1-1 24	S12099001	2	ナツクル"ピン	PIN	
1-1 25	048050342	4	トメフE5	STOP RING E5	
1-1 26	S12475100	1	メントリイタR"タイ	TUCKING BLADE (R) LARGE	
1-1 27	S12476100	1	メントリイタL"タイ	TUCKING BLADE (L) LARGE	
1-1 28	018400632	4	アナホ"ルト4X6	BOLT 4X6	
1-1 29	028040242	4	ハ"ネサ"ガ"ネ2-4	SPRING WASHER 2-4	
1-1 30	S12214000	1	スハ"イラル640L	SPIRAL 640L	
1-1 31	S12106000	1	マルチコネクタP	MULTI CONNECTOR (P)	
1-1 32	S12285---	1	オリイタR-3カク	TUCKING BLADE (R) (TRIANGLE)	
1-1 33	S12286---	1	オリイタL-3カク	TUCKING BLADE (L) (TRIANGLE)	
1-1 34	S12287---	1	オリイタRD-3カク	TUCKING BLADE (RD) (TRIANGLE)	
1-1 35	S12288---	1	オリイタLD-3カク	TUCKING BLADE (LD) (TRIANGLE)	
1-1 36	018400632	8	アナホ"ルト4X6	BOLT 4X6	
1-1 37	028040242	8	ハ"ネサ"ガ"ネ2-4	SPRING WASHER 2-4	
1-1 38	025040232	12	ヒラサ"ガ"ネチユウ4	PLAIN WASHER 4	
1-1 39	S12102000	4	ツインロツト"シリンダ"-クミ	TWIN ROD CYLINDER ASSEMBLY	
1-1 39-1	S12103000	4	ツインロツト"シリンダ"-	TWIN ROD CYLINDER	
1-1 39-2	S11433000	8	ホースニツフ"ル4M5	HOSE NIPPLE 4M5	
1-1 40	028040243	8	ハ"ネサ"ガ"ネ2-4	SPRING WASHER 2-4	
1-1 41	062402016	8	ナヘ"コM4X20	SCREW M4X20	
1-1 42	S04159000	3	バンド"1M	BAND 1M	
1-1 43	S12205000	1	エアホ-ス4X2.5-29	AIR TUBE 4X2.5-29 (L=7500)	
1-1 44	S12104000	6	ユニオンワイ4	UNION-Y 4	
1-1 45	S12289---	1	オリササエ-3カク	FOLDING CLAMP (TRIANGLE)	
1-1 46	S12297000	2	スポンジ"2-30	SPONGE 2-30	
1-1 47	S12291001	2	アシ"ヤストネジ"	ADJUST SCREW	
1-1 48	S12294001	2	トリツクイタ(オリササエ)	FITTING PLATE (FOLDING CLAMP)	
1-1 49	062401006	4	ナヘ"コ4X10	SCREW 4X10	
1-1 50	028040243	4	ハ"ネサ"ガ"ネ2-4	SPRING WASHER 2-4	
1-1 51	028060243	2	ハ"ネサ"ガ"ネ2-6	SPRING WASHER 2-6	
1-1 52	021060206	2	ナツト2シユ6	NUT 6	
1-1 53	S15564000	1	チ-M5クミ	T-M5 ASSEMBLY	
1-1 53-1	S15563000	1	チ-M5	T-M5	
1-1 53-2	S04905000	1	ハーフユニオン	HALF UNION	
1-1 53-3	S14328000	2	シホ"リ"ベン	THROTTLE VALVE	

S. 折曲関係 (特別注文部品)/Folding margin mechanism (Option parts)/Faltungsvorrichtung (Sonderzubehör)/
 Mécanisme de marge d'ourlet (Pièces en option)/Mecanismo de margen de plegado (Piezas a opción)

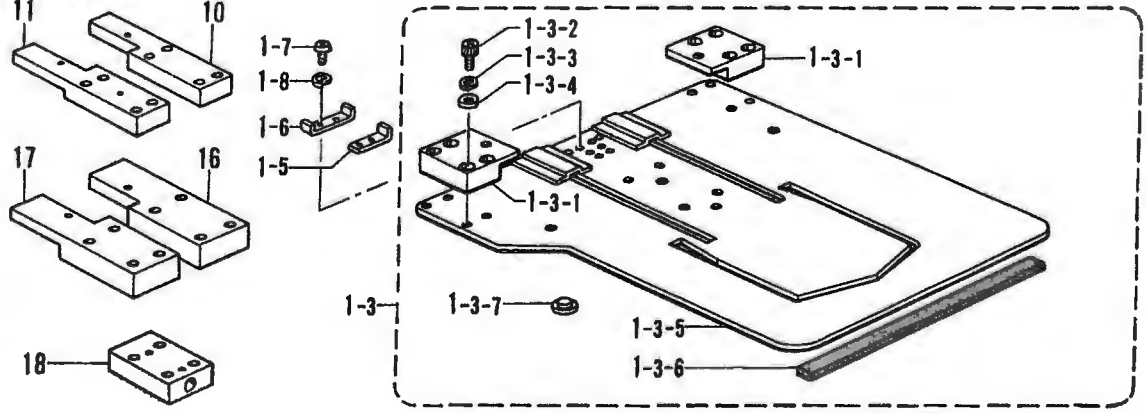
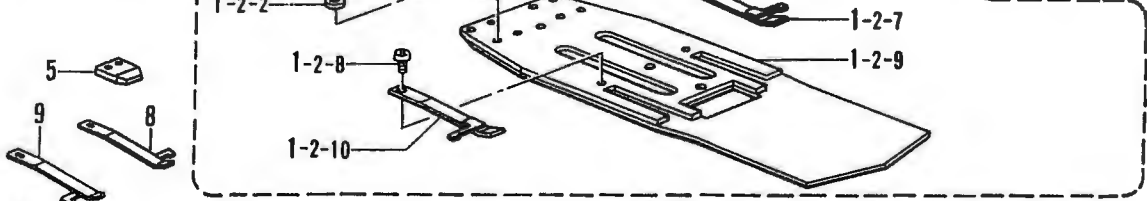
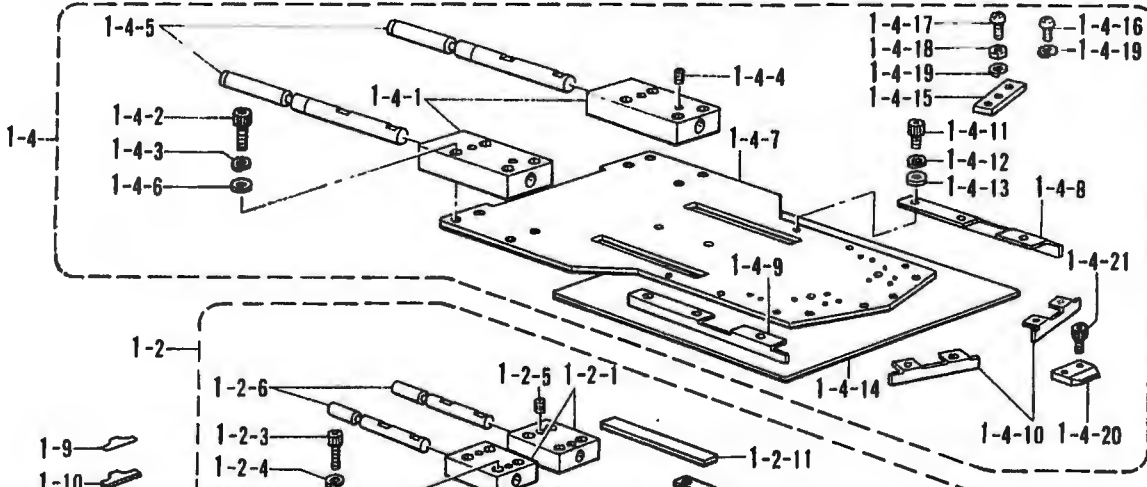
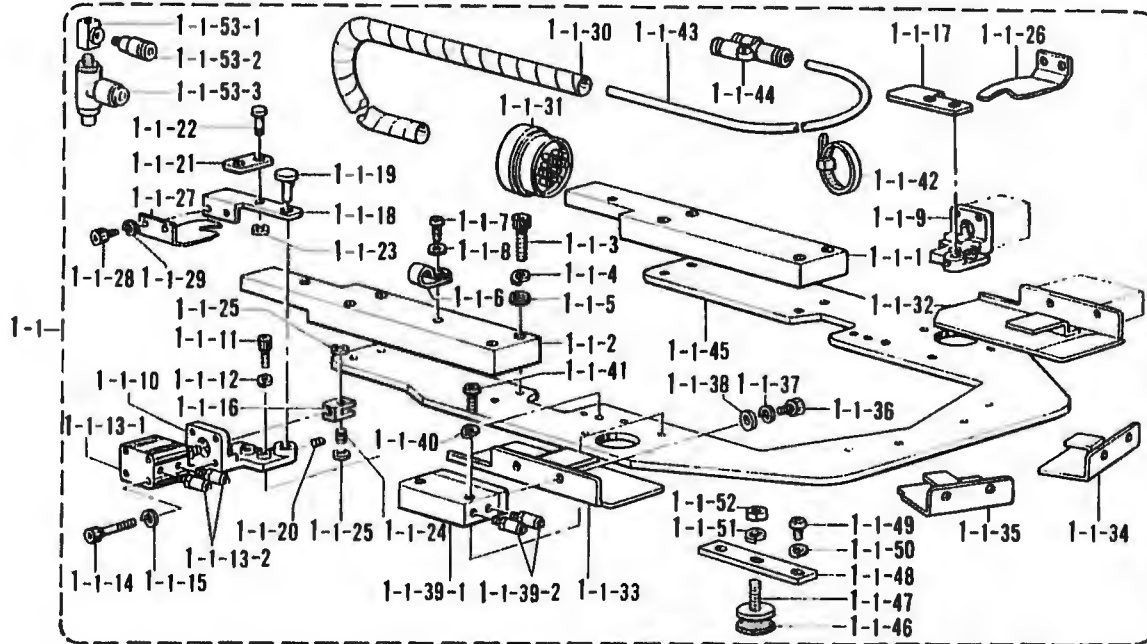

S. 折曲ゲ関係 (特別注文部品)/Folding margin mechanism (Option parts)/Faltungsvorrichtung (Sonderzubehör)/
 Mécanisme de marge d'ourlet (Pièces en option)/Mecanismo de margen de plegado (Piezas a opción)

RII NO	CODI	Q'TY	ヒンメイ	NAME OF PARTS	RMKS
1 2	S12292	1	ケージクミ-3カク	CENTER BLADE ASSEMBLY (TRIANGLE)	
1 2 1	S12107001	2	コネクトブロック(ケージ)	CONNECT BLOCK (CENTER BLADE) (GAGE)	
1 2 2	025040232	8	ヒラサガネチユウ4	PLAIN WASHER 4	
1 2 3	018402032	8	アナボルト4X20	BOLT 4X20	
1 2 4	028040242	8	ハネサガネ2-4	SPRING WASHER 2-4	
1 2 5	014500522	4	アナトメネシ5クホミ	SET SCREW 5	
1 2 6	S12108001	2	コネクトピン(ケージ)	PIN (CENTER BLADE) (GAGE)	
1 2 7	S12109000	1	イタハネR	PLATE SPRING (R)	
1 2 8	060300414	2	ハイント3X4	SCREW 3X4	
1 2 9	S12793	1	ケージ-3カク	CENTER BLADE (TRIANGLE)	
1 2 10	S12105000	1	イタハネL	PLATE SPRING (L)	
1-2-11	S12278000	2	ウケイタ(ケージ)	SUPPORT PLATE (CENTER BLADE) (GAGE)	
1 3	S12295	1	オサエクミ-3カク	SEWING CLAMP ASSEMBLY (TRIANGLE)	
1 3 1	S12110001	2	コネクトブロック(オサエ)	CONNECT BLOCK (PRESSER)	
1-3-2	018401022	8	アナボルト4X10	BOLT 4X10	
1 3 3	028040242	8	ハネサガネ2-4	SPRING WASHER 2-4	
1-3-4	025040232	8	ヒラサガネチユウ4	PLAIN WASHER 4	
1 3 5	S12296	1	オサエ-3カク	SEWING CLAMP (TRIANGLE)	
1 3 6	S12298000	2	フォーム3X15X1000	FORM 3X15X1000	
1-3-7	S12279000	6	ウケイタ(オサエ)	SUPPORT PLATE (PRESSER)	
1-4	S12299	1	ナカオサエクミ-3カク	INNER CLAMP ASSEMBLY (TRIANGLE)	
1-4-1	S12113001	2	コネクトブロック(ナカ)	CONNECT BLOCK (INNER)	
1-4-2	018502522	8	アナボルト5X25	BOLT 5X25	
1-4-3	028050242	8	ハネサガネ2-5	SPRING WASHER 2-5	
1-4-4	014500522	4	アナトメネシ5クホミ	SET SCREW 5	
1-4-5	S12114001	2	コネクトピン(ナカ)	PIN (INNER)	
1-4-6	025050232	8	ヒラサガネチユウ-5	PLAIN WASHER 5	
1-4-7	S12300	1	ナカオサエ-3カク	INNER CLAMP (TRIANGLE)	
1-4-8	S12301	1	ナカオサエウエ1-3カク	INNER CLAMP BLADE-1 (TRIANGLE)	
1-4-9	S12302	1	ナカオサエウエ2-3カク	INNER CLAMP BLADE-2 (TRIANGLE)	
1-4-10	S12303	2	ナカオサエウエ3-3カク	INNER CLAMP BLADE-3 (TRIANGLE)	
1-4-11	018300532	8	アナボルト3X5	BOLT 3X5	
1-4-12	028030242	8	ハネサガネ2-3	SPRING WASHER 2-3	
1-4-13	025030232	8	ヒラサガネチユウ3	PLAIN WASHER 3	
1-4-14	S12117000	1	フォーム2X200X200	FORM 2X200X200	
1-4-15	S12485001	2	トリツケイタ(ナカオサエ)	FITTING PLATE (INNER CLAMP)	
1-4-16	062400806	4	ナヘコ4X8	SCREW 4X8	
1-4-17	062401416	2	ナヘコ4X14	SCREW 4X14	
1-4-18	021400103	2	ナツト1シユ4	NUT 4	
1-4-19	028040243	6	ハネサガネ2-4	SPRING WASHER 2-4	
1-4-20	S12487000	4	オリイタウケ(ナカオサエ)	FOLDING PLATE SUPPORT (INNER CLAMP)	
1-4-21	018300532	8	アナボルト3X5	BOLT 3X5	
1-5	S12111001	3	スリットC	SLIT (C)	
1-6	S12112001	3	スリットD	SLIT (D)	
1-7	062300502	6	ナヘコ3X5	SCREW 3X5	
1-8	028030242	6	ハネサガネ2-3	SPRING WASHER 2-3	
1-9	S16514000	2	スペーサ0.05	SPACER 0.05	
1-10	S16513000	2	スペーサ0.1	SPACER 0.1	
5	S12494000	1	オリイタウケシヨウ	FOLDING PLATE SUPPORT (SMALL)	
8	S15565000	1	イタハネR0.8	PLATE SPRING (R) 0.8	
9	S15566000	1	イタハネL0.8	PLATE SPRING (L) 0.8	
10	S12507001	1	コネクトブロックSR	CONNECT BLOCK (SR)	
11	S12508001	1	コネクトブロックSL	CONNECT BLOCK (SL)	
16	S21121001	1	コネクトブロックSSR	CONNECT BLOCK (SSR)	
17	S21122001	1	コネクトブロックSSL	CONNECT BLOCK (SSL)	
18	S21123001	2	コネクトブロックS	CONNECT BLOCK (S)	

S. 折曲ケ関係 (特別注文部品)/Folding margin mechanism (Option parts)/Faltungsvorrichtung (Sonderzubehör)/
 Mécanisme de marge d'ourlet (Pièces en option)/Mecanismo de margen de plegado (Piezas a opción)

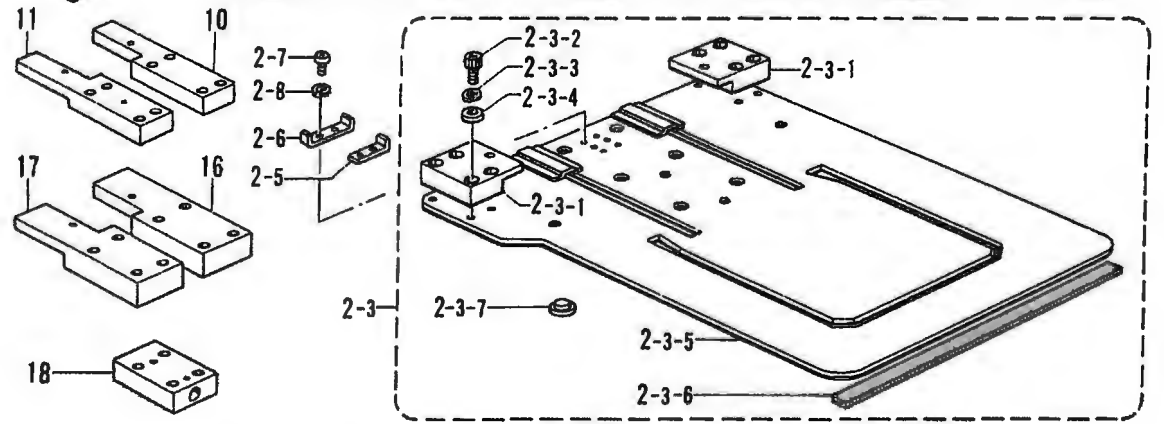
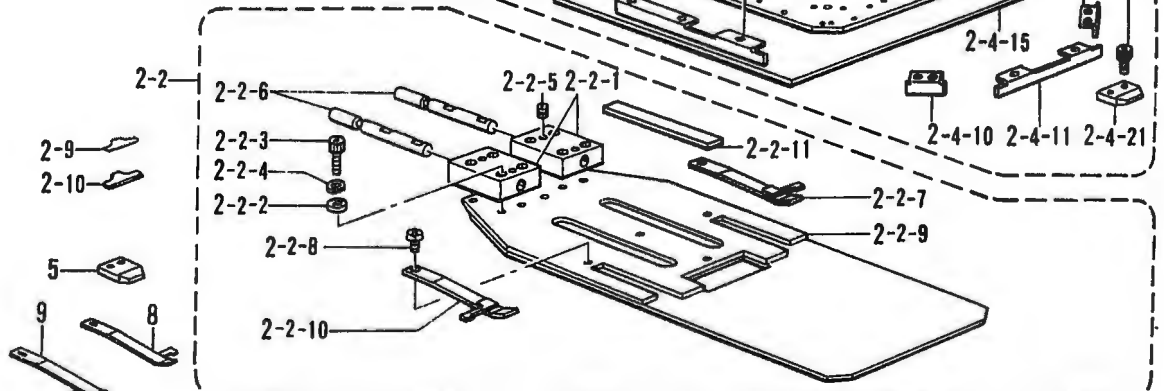
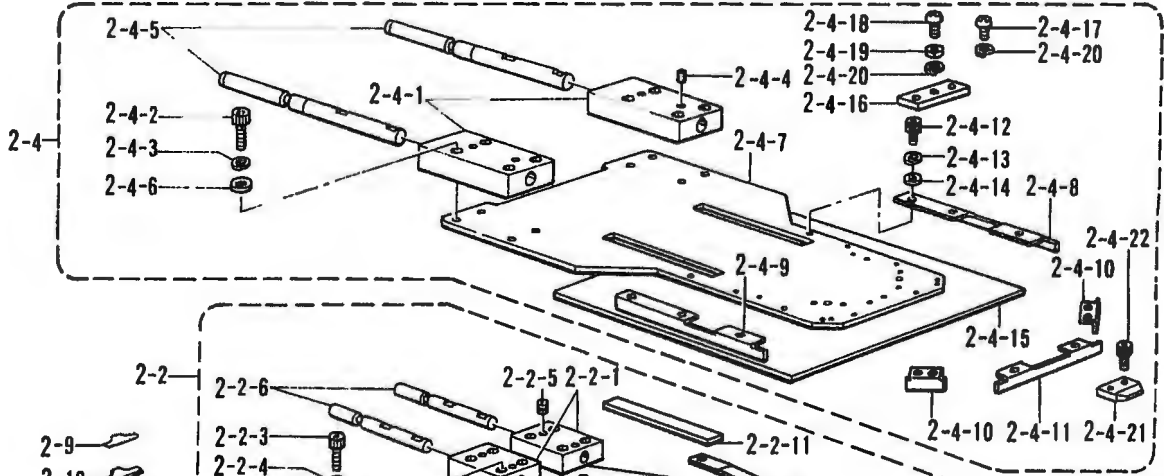
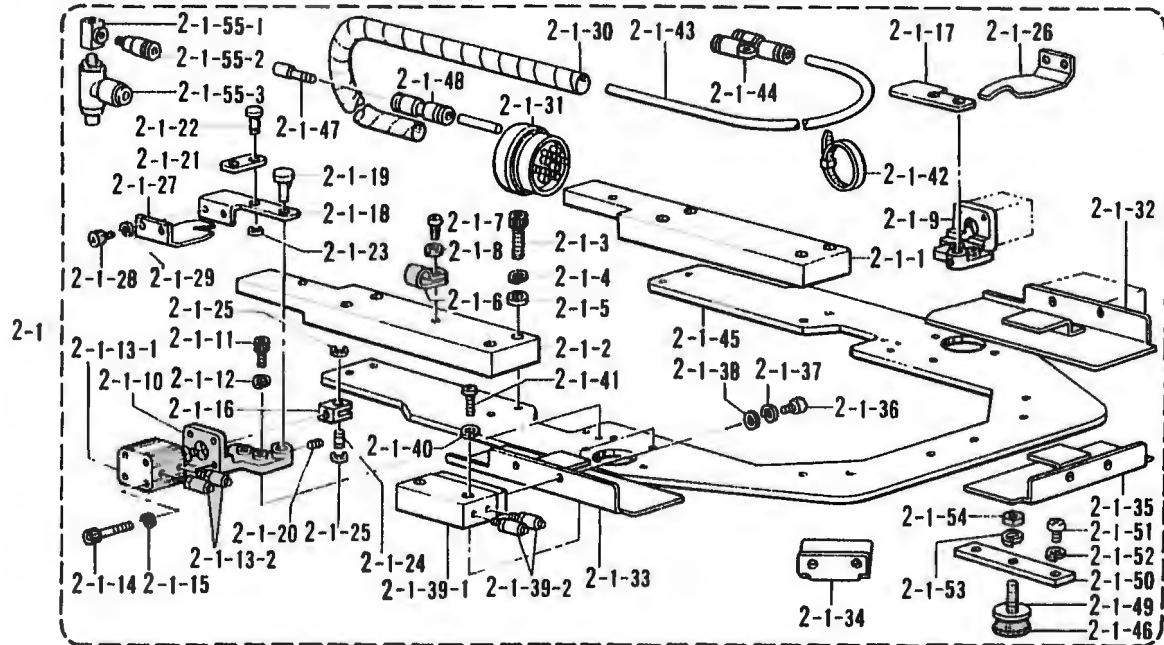

S. 11447 1011 (特別注品部) / Folding margin mechanism (Option parts) / Faltungsvorrichtung (Sonderzubehör) / Mécanisme de marge d'ourlet (Pièces en option) / Mecanismo de margen de plegado (Piezas a opción)

RII NO	CODE	Q'TY	ヒンメイ	NAME OF PARTS	RMKS
2	S12305	1	オリキクミ-5カク	FOLDING GROUP ASSEMBLY (MITER)	
2 1	S12306	1	オリササイクミ-5カク	FOLDING CLAMP ASSEMBLY (MITER)	
2 1 1	S12086001	1	コネクタブ"ロツクR	CONNECT BLOCK (R)	
2 1 2	S12087001	1	コネクタブ"ロツクL	CONNECT BLOCK (L)	
2 1 3	018502522	8	アナホ"ルト5X25	BOLT 5X25	
2 1 4	028050242	8	ハ"ネサ"カ"ネ2-5	SPRING WASHER 2-5	
2 1 5	025050232	8	ヒラサ"カ"ネチユウ-5	PLAIN WASHER 5	
2 1 6	525907000	1	コード"ホルダ"9N	CORD HOLDER 9N	
2 1 7	062401006	1	ナヘ"コ4X10	SCREW 4X10	
2 1 8	025040233	1	ヒラサ"カ"ネチユウ4	PLAIN WASHER 4	
2 1 9	S12088009	1	レハ"ー"ヘ"ー"スR	LEVER BASE (R)	
2 1 10	S12089009	1	レハ"ー"ヘ"ー"スL	LEVER BASE (L)	
2 1 11	018401222	4	アナホ"ルト4X12	BOLT 4X12	
2-1 12	02B040242	4	ハ"ネサ"カ"ネ2-4	SPRING WASHER 2-4	
2-1 13	S12090000	2	シリンダ"ー"12X10クニ	CYLINDER 12X10 ASSEMBLY	
2-1 13 1	S12091000	2	シリンダ"ー"12X10	CYLINDER 12X10	
2 1 13 2	S11433000	4	ホースニツプル4M5	HOSE NIPPLE 4M5	
2-1 14	S12092000	8	CQ2ホ"ルトM3X30	CQ2 BOLT M3X30	
2-1 15	028030243	8	ハ"ネサ"カ"ネ2-3	SPRING WASHER 2-3	
2-1-16	S12093001	2	ナツクル	KNUCKLE	
2-1 17	S12094001	1	ヒンシ"R	HINGE (R)	
2-1-18	S12095001	1	ヒンシ"L	HINGE (L)	
2-1-19	S12096001	2	ヒンシ"ピン	PIN	
2-1-20	014400522	2	アナクホ"ミ4X5	SET SCREW 4X5	
2-1-21	S12097001	2	タイフ"プレート	TIE PLATE	
2-1-22	S12098001	2	ピン	PIN	
2-1 23	048050342	2	トメワE5	STOP RING E5	
2-1-24	S12099001	2	ナツクルピン	PIN	
2-1-25	048050342	4	トメワE5	STOP RING E5	
2-1-26	S12475100	1	メントリイタR"タイ	TUCKING BLADE (R) LARGE	
2-1-27	S12476100	1	メントリイタL"タイ	TUCKING BLADE (L) LARGE	
2-1-28	018400632	4	アナホ"ルト4X6	BOLT 4X6	
2-1-29	028040242	4	ハ"ネサ"カ"ネ2-4	SPRING WASHER 2-4	
2-1-30	S12214000	1	スパイラル640L	SPIRAL 640L	
2-1-31	S12106000	1	マルチコネクタP	MULTI CONNECTOR (P)	
2-1-32	S12307---	1	オリイタR-5カク	TUCKING BLADE (R) (MITER)	
2-1-33	S12308---	1	オリイタL-5カク	TUCKING BLADE (L) (MITER)	
2-1-34	S12309---	2	オリイタS-5カク	TUCKING BLADE (S) (MITER)	
2-1-35	S12310---	1	オリイタM-5カク	TUCKING BLADE (M) (MITER)	
2-1-36	018400632	10	アナホ"ルト4X6	BOLT 4X6	
2-1-37	028040242	10	ハ"ネサ"カ"ネ2-4	SPRING WASHER 2-4	
2-1-38	025040232	14	ヒラサ"カ"ネチユウ4	PLAIN WASHER 4	
2-1-39	S12102000	5	ツインロッド"シリンダ"ークミ	TWIN ROD CYLINDER ASSEMBLY	
2-1-39-1	S12103000	5	ツインロッド"シリンダ"ー	TWIN ROD CYLINDER	
2-1-39-2	S11433000	10	ホースニツプル4M5	HOSE NIPPLE 4M5	
2-1-40	028040243	10	ハ"ネサ"カ"ネ2-4	SPRING WASHER 2-4	
2-1-41	062402016	10	ナヘ"コM4X20	SCREW M4X20	
2-1-42	S04159000	2	バンド"1M	BAND 1M	
2-1-43	S12205000	1	エアホース4X2.5-29	AIR TUBE 4X2.5-29 (L=7500)	
2-1-44	S12104000	8	ユニオンワイ4	UNION-Y 4	
2-1-45	S12311---	1	オリササエ-5カク	FOLDING CLAMP (MITER)	
2-1-46	S12297000	2	スポンジ"2-30	SPONGE 2-30	
2-1-47	S04897000	2	メクラセン	BLIND CAP	
2-1-48	S04587000	2	ストレートツキ"テ	STRAIGHT JOINT	
2-1-49	S12291001	2	アシ"ヤストネジ"	ADJUST SCREW	
2-1-50	S12294001	2	トリツケイタ(オリササエ)	FITTING PLATE (FOLDING CLAMP)	
2-1-51	062401006	4	ナヘ"コ4X10	SCREW 4X10	
2-1-52	028040243	4	ハ"ネサ"カ"ネ2-4	SPRING WASHER 2-4	
2-1-53	028060243	2	ハ"ネサ"カ"ネ2-6	SPRING WASHER 2-6	
2-1-54	021060206	2	ナツト2シユ6	NUT 6	

S. 折曲ケ関係 (特別注文部品)/Folding margin mechanism (Option parts)/Faltungsvorrichtung (Sonderzubehör)/
 Mécanisme de marge d'ourlet (Pièces en option)/Mecanismo de margen de plegado (Piezas a opción)

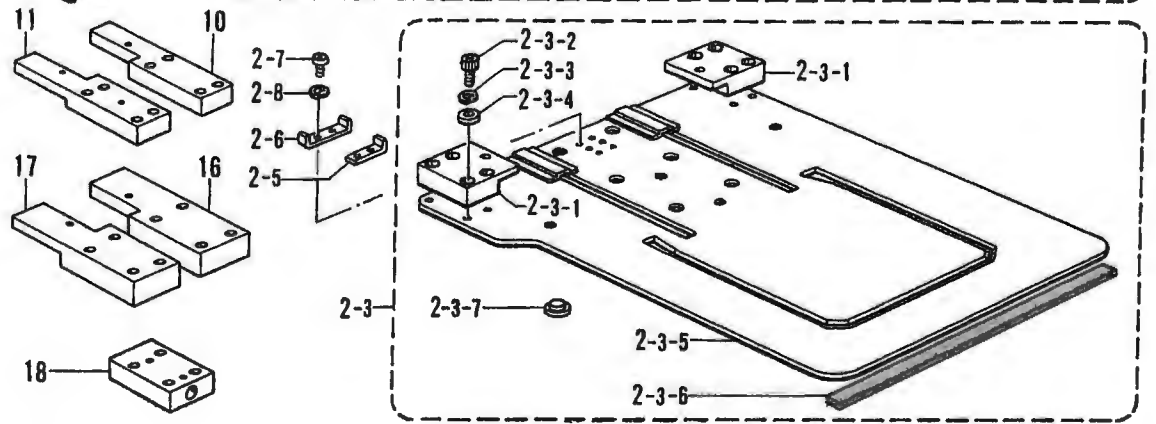
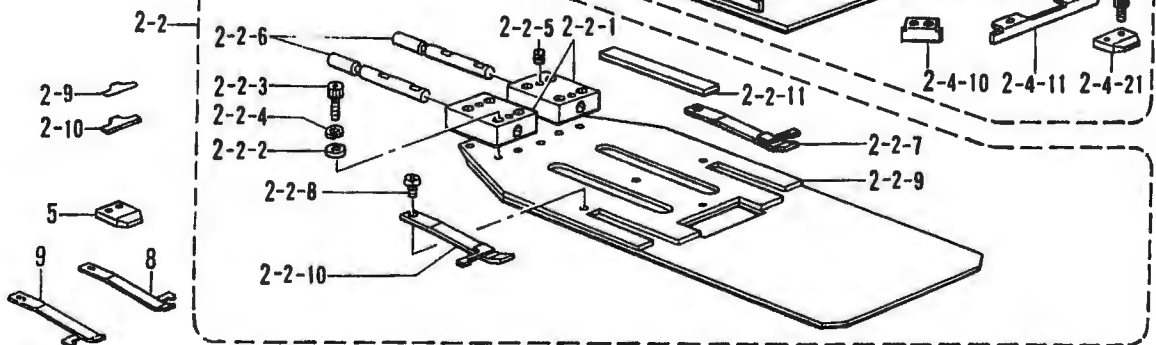
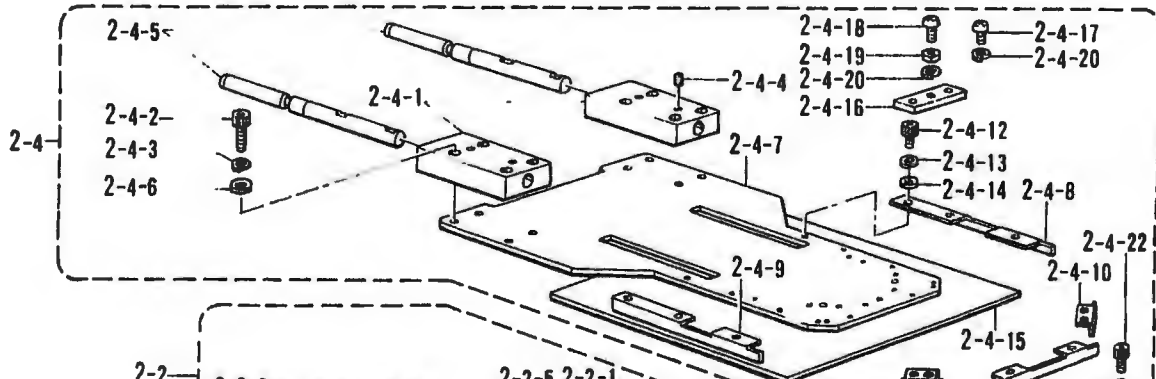
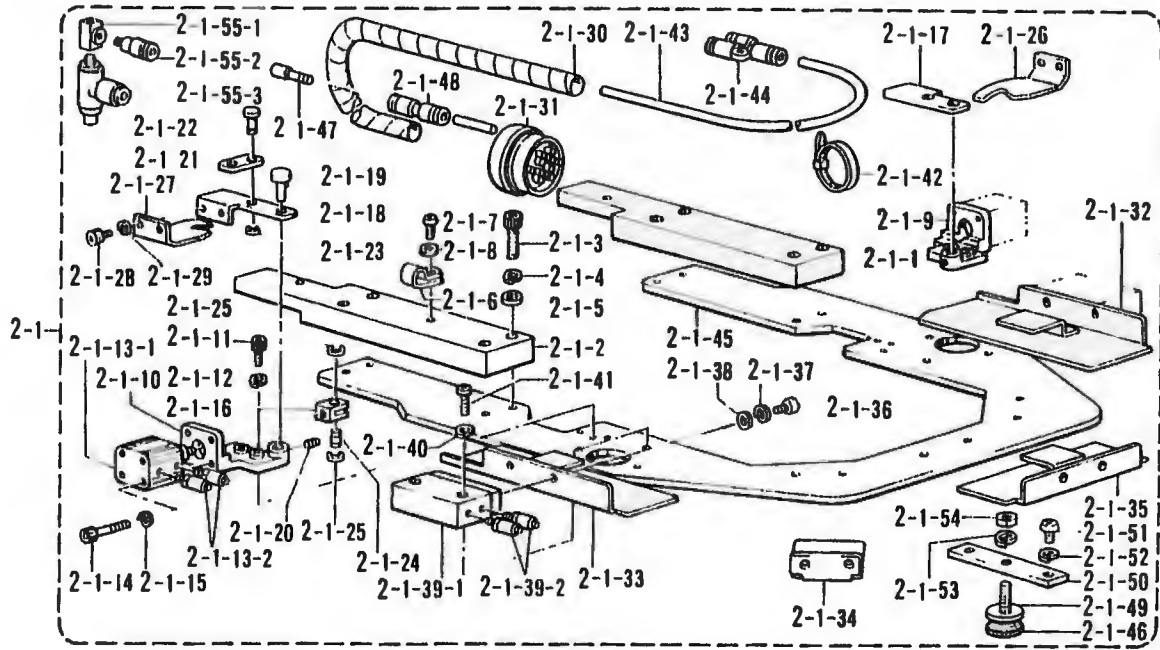

S. 折曲ゲ関係 (特別注文部品)/Folding margin mechanism (Option parts)/Faltungsvorrichtung (Sonderzubehör)/
 Mécanisme de marge d'ourlet (Pièces en option)/Mecanismo de margen de plegado (Piezas a opción)

REF NO	CODF	Q'TY	品名	NAME OF PARTS	RMKS
2 1 55	S15564000	1	チーM5クミ	T M5 ASSEMBLY	
2 1 55 1	S15563000	1	チーM5	T M5	
2 1 55 2	S04905000	1	ハーフユニオン	HALF UNION	
2 1 55 3	S14328000	2	ンボ"リハ"ン	THROTTLE VALVE	
2 2	S12312	1	ケ"ー"ジ"クミ-5カク	CENTER BLADE ASSEMBLY (MITER)	
2 2 1	S12107001	2	コネク"ト"ブロック(ケ"ー"ジ")	CONNECT BLOCK (CENTER BLADE) (GAGE)	
2 2 2	025040232	8	ヒラサ"カ"ネチユウ4	PLAIN WASHER 4	
2 2 3	018402032	8	アナボ"ルト4X20	BOLT 4X20	
2 2 4	028040242	8	ハ"ネサ"カ"ネ2-4	SPRING WASHER 2 4	
2 2 5	014500522	4	アナトメネシ"5クホ"ミ	SET SCREW 5	
2-2 6	S12108001	2	コネク"ト"ピン(ケ"ー"ジ")	PIN (CENTER BLADE) (GAGE)	
2-2 7	S12109000	1	イタハ"ネR	PLATE SPRING (R)	
2-2 8	060300414	2	ハ"イント"3X4	SCREW 3X4	
2-2 9	S12313	1	ケ"ー"ジ"-5カク	CENTER BLADE (MITER)	
2-2-10	S12105000	1	イタハ"ネL	PLATE SPRING (L)	
2-2 11	S12278000	2	ウケイ"タ(ケ"ー"ジ")	SUPPORT PLATE (CENTER BLADE) (GAGE)	
2-3	S12314---	1	オサエ"クミ-5カク	SEWING CLAMP ASSEMBLY (MITER)	
2-3 1	S12110001	2	コネク"ト"ブロック(オサエ)	CONNECT BLOCK (PRESSER)	
2-3 2	018401022	8	アナボ"ルト4X10	BOLT 4X10	
2-3 3	028040242	8	ハ"ネサ"カ"ネ2-4	SPRING WASHER 2-4	
2-3 4	025040232	8	ヒラサ"カ"ネチユウ4	PLAIN WASHER 4	
2-3 5	S12315---	1	オサエ-5カク	SEWING CLAMP (MITER)	
2-3 6	S12298000	2	フォーム3X15X1000	FORM 3X15X1000	
2-3 7	S12279000	6	ウケイ"タ(オサエ)	SUPPORT PLATE (PRESSER)	
2-4	S12316---	1	ナカオサエ"クミ-5カク	INNER CLAMP ASSEMBLY (MITER)	
2-4 1	S12113001	2	コネク"ト"ブロック(ナカ)	CONNECT BLOCK (INNER)	
2-4 2	018502522	8	アナボ"ルト5X25	BOLT 5X25	
2-4 3	028050242	8	ハ"ネサ"カ"ネ2-5	SPRING WASHER 2-5	
2-4 4	014500522	4	アナトメネシ"5クホ"ミ	SET SCREW 5	
2-4 5	S12114001	2	コネク"ト"ピン(ナカ)	PIN (INNER)	
2-4 6	025050232	8	ヒラサ"カ"ネチユウ-5	PLAIN WASHER 5	
2-4 7	S12317---	1	ナカオサエ-5カク	INNER CLAMP (MITER)	
2-4 8	S12318---	1	ナカオサエ"ウエ1-5カク	INNER CLAMP BLADE 1 (MITER)	
2-4 9	S12319---	1	ナカオサエ"ウエ2-5カク	INNER CLAMP BLADE 2 (MITER)	
2-4 10	S12320---	2	ナカオサエ"ウエ3-5カク	INNER CLAMP BLADE 3 (MITER)	
2-4 11	S12321---	1	ナカオサエ"ウエ4-5カク	INNER CLAMP BLADE 4 (MITER)	
2-4 12	018300532	10	アナボ"ルト3X5	BOLT 3X5	
2-4 13	028030242	10	ハ"ネサ"カ"ネ2-3	SPRING WASHER 2-3	
2-4 14	025030232	10	ヒラサ"カ"ネチユウ3	PLAIN WASHER 3	
2-4 15	S12117000	1	フォーム2X200X200	FORM 2X200X200	
2-4 16	S12485001	2	トリツケイ"タ(ナカオサエ)	FITTING PLATE (INNER CLAMP)	
2-4 17	062400806	4	ナヘ"コ4X8	SCREW 4X8	
2-4 18	062401416	2	ナヘ"コ4X14	SCREW 4X14	
2-4 19	021400103	2	ナツ"ト1シユ4	NUT 4	
2-4 20	028040243	6	ハ"ネサ"カ"ネ2-4	SPRING WASHER 2-4	
2-4 21	S12487000	3	オリイ"タウケ(ナカオサエ)	FOLDING PLATE SUPPORT (INNER CLAMP)	
2-4 22	018300532	6	アナボ"ルト3X5	BOLT 3X5	
2-5	S12111001	3	スリツ"C	SLIT (C)	
2-6	S12112001	3	スリツ"D	SLIT (D)	
2-7	062300502	6	ナヘ"コ3X5	SCREW 3X5	
2-8	028030242	6	ハ"ネサ"カ"ネ2-3	SPRING WASHER 2-3	
2-9	S16514000	2	スヘ"ーサ0.05	SPACER 0.05	
2-10	S16513000	2	スヘ"ーサ0.1	SPACER 0.1	
5	S12494000	1	オリイ"タウケシヨウ	FOLDING PLATE SUPPORT (SMALL)	
8	S15565000	1	イタハ"ネR0.8	PLATE SPRING (R) 0.8	
9	S15566000	1	イタハ"ネL0.8	PLATE SPRING (L) 0.8	
10	S12507001	1	コネク"ト"ブロックSR	CONNECT BLOCK (SR)	
11	S12508001	1	コネク"ト"ブロックSL	CONNECT BLOCK (SL)	
16	S21121001	1	コネク"ト"ブロックSSR	CONNECT BLOCK (SSR)	
17	S21122001	1	コネク"ト"ブロックSSL	CONNECT BLOCK (SSL)	
18	S21123001	2	コネク"ト"ブロックS	CONNECT BLOCK (S)	

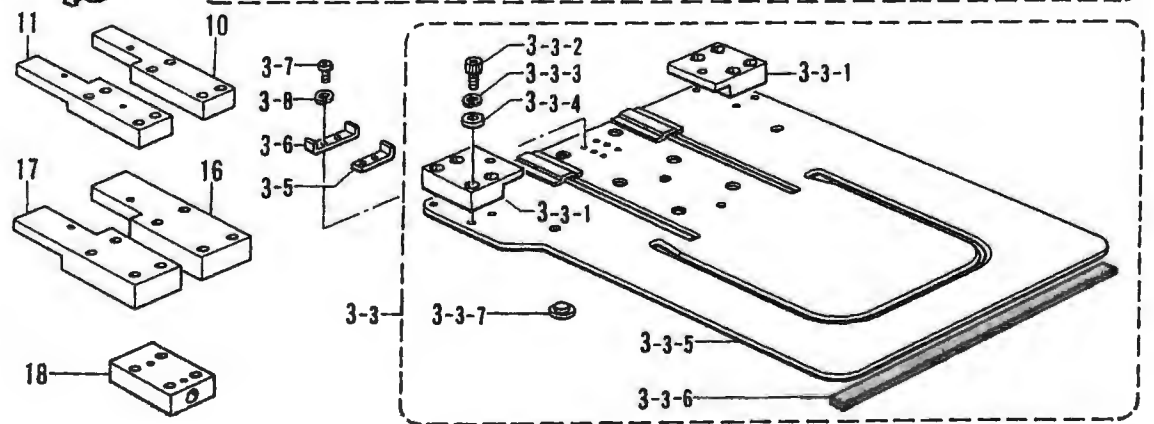
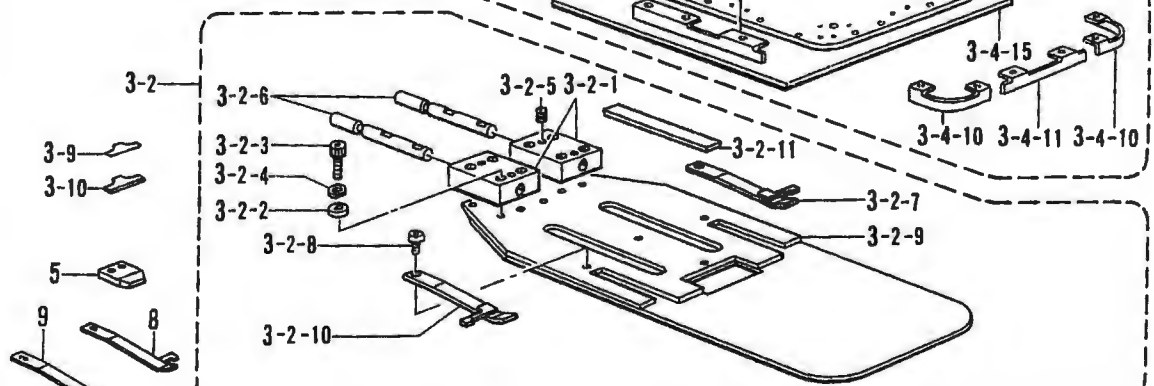
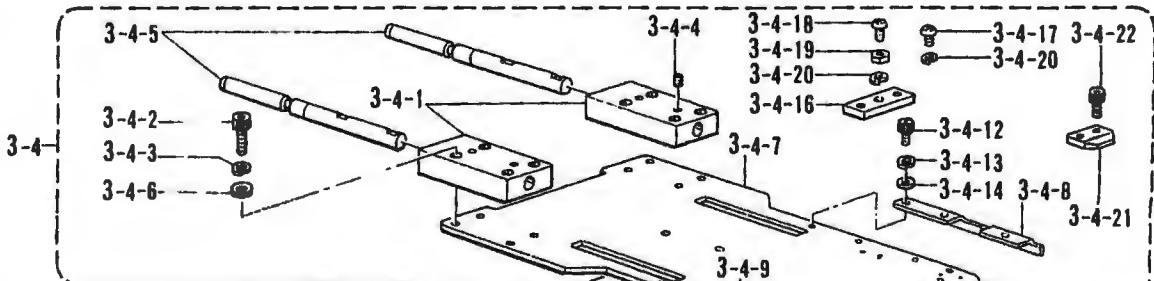
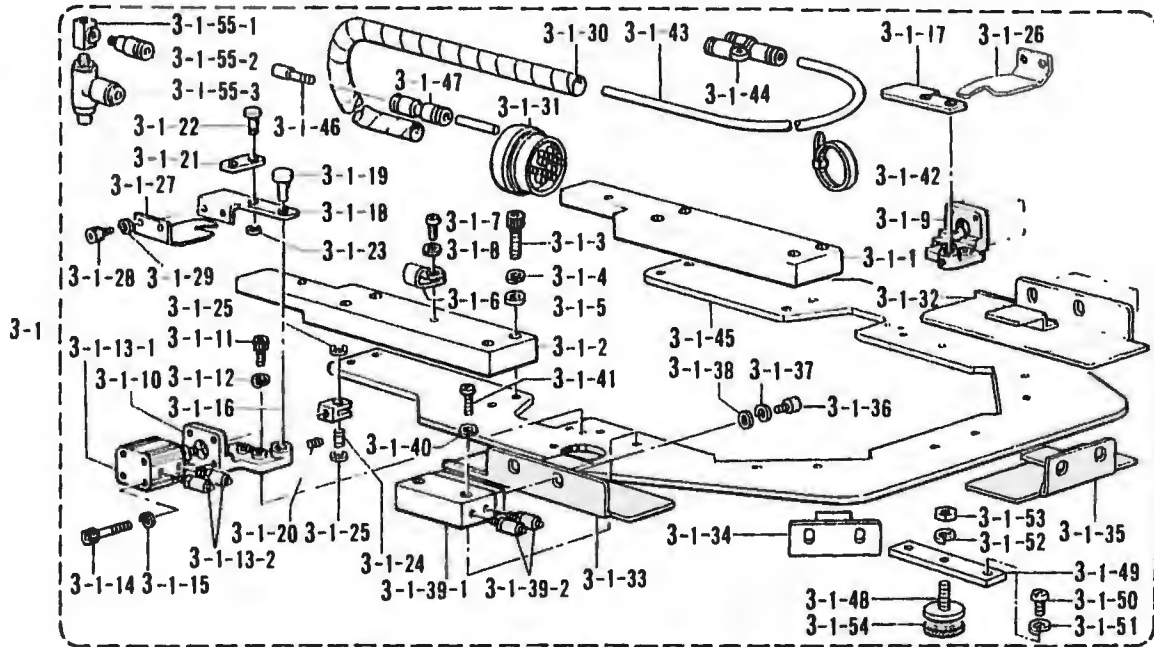

S. 折曲ゲ関係 (特別注文部品)/Folding margin mechanism (Option parts)/Faltungsvorrichtung (Sonderzubehör)/
 Mécanisme de marge d'ourlet (Pièces en option)/Mecanismo de margen de plegado (Piezas a opción)

RII NO	CODE	Q'TY	ヒンメイ	NAME OF PARTS	RMKS
3	S12323	1	オリキクミーマル	FOLDING GROUP ASSEMBLY (ROUND)	
3 1	S12324	1	オリササエクミーマル	FOLDING CLAMP ASSEMBLY (ROUND)	
3 1 1	S12086001	1	コネクタブ"ロツクR	CONNECT BLOCK (R)	
3 1 2	S12087001	1	コネクタブ"ロツクL	CONNECT BLOCK (L)	
3 1 3	018502522	8	アナボルト5X25	BOLT 5X25	
3 1 4	028050242	8	ハ"ネサ"カ"ネ2-5	SPRING WASHER 2-5	
3-1 5	025050232	8	ヒラサ"カ"ネチユウ-5	PLAIN WASHER 5	
3-1 6	525907000	1	コード"ホルダ"9N	CORD HOLDER 9N	
3-1 7	062401006	1	ナヘ"コ4X10	SCREW 4X10	
3 1 8	025040233	1	ヒラサ"カ"ネチユウ4	PLAIN WASHER 4	
3-1-9	S12088009	1	レハ"ーヘ"ーSR	LEVER BASE (R)	
3-1 10	S12089009	1	レハ"ーヘ"ーSL	LEVER BASE (L)	
3 1 11	018401222	4	アナボルト4X12	BOLT 4X12	
3-1 12	028040242	4	ハ"ネサ"カ"ネ2-4	SPRING WASHER 2-4	
3-1 13	S12090000	2	シリンダ"ー12X10クミ	CYLINDER 12X10 ASSEMBLY	
3-1 13 1	S12091000	2	シリンダ"ー12X10	CYLINDER 12X10	
3-1 13 2	S11433000	4	ホースニツプ"ル4M5	HOSE NIPPLE 4M5	
3-1 14	S12092000	8	CQ2ボルトM3X30	CQ2 BOLT M3X30	
3-1 15	028030243	8	ハ"ネサ"カ"ネ2-3	SPRING WASHER 2-3	
3-1-16	S12093001	2	ナツクル	KNUCKLE	
3-1-17	S12094001	1	ヒンジ"R	HINGE (R)	
3-1-18	S12095001	1	ヒンジ"L	HINGE (L)	
3-1-19	S12096001	2	ヒンジ"ピン	PIN	
3-1-20	014400522	2	アナクボ"ミ4X5	SET SCREW 4X5	
3-1-21	S12097001	2	タイフ"レート	TIE PLATE	
3-1 22	S12098001	2	ピン	PIN	
3 1-23	048050342	2	トメフE5	STOP RING E5	
3-1-24	S12099001	2	ナツクルピン	PIN	
3-1-25	048050342	4	トメフE5	STOP RING E5	
3-1-26	S12475100	1	メントリイタR"タイ	TUCKING BLADE (R) LARGE	
3-1-27	S12476100	1	メントリイタL"タイ	TUCKING BLADE (L) LARGE	
3-1-28	018400632	4	アナボルト4X6	BOLT 4X6	
3-1-29	028040242	4	ハ"ネサ"カ"ネ2-4	SPRING WASHER 2-4	
3-1-30	S12214000	1	スパ"イラル640L	SPIRAL 640L	
3-1-31	S12106000	1	マルチコネクタP	MULTI CONNECTOR (P)	
3-1-32	S12325---	1	オリイタR"マル	TUCKING BLADE (R) (ROUND)	
3-1-33	S12326---	1	オリイタL"マル	TUCKING BLADE (L) (ROUND)	
3-1-34	S12327---	2	オリイタS"マル	TUCKING BLADE (S) (ROUND)	
3-1-35	S12328---	1	オリイタM"マル	TUCKING BLADE (M) (ROUND)	
3-1-36	018400632	10	アナボルト4X6	BOLT 4X6	
3-1-37	028040242	10	ハ"ネサ"カ"ネ2-4	SPRING WASHER 2-4	
3-1-38	025040232	14	ヒラサ"カ"ネチユウ4	PLAIN WASHER 4	
3-1-39	S12102000	5	ツインロッド"シリンダ"ークミ	TWIN ROD CYLINDER ASSEMBLY	
3-1-39-1	S12103000	5	ツインロッド"シリンダ"ー	TWIN ROD CYLINDER	
3-1-39-2	S11433000	10	ホースニツプ"ル4M5	HOSE NIPPLE 4M5	
3-1-40	028040243	10	ハ"ネサ"カ"ネ2-4	SPRING WASHER 2-4	
3-1-41	062402016	10	ナヘ"コM4X20	SCREW M4X20	
3-1-42	S04159000	2	バンド"1M	BAND 1M	
3-1-43	S12205000	1	エアホース4X2.5-29	AIR TUBE 4X2.5-29 (L=7500)	
3-1-44	S12104000	8	ユニオンワイ4	UNION-Y 4	
3-1-45	S12329---	1	オリササエーマル	FOLDING CLAMP (ROUND)	
3-1-46	S04897000	2	メクラセン	BLIND CAP	
3-1-47	S04587000	2	ストレートツキ"テ	STRAIGHT JOINT	
3-1-48	S12291001	2	アジ"ヤストネジ"	ADJUST SCREW	
3-1-49	S12294001	2	トリツケイタ(オリササエ)	FITTING PLATE (FOLDING CLAMP)	
3-1-50	062401006	4	ナヘ"コ4X10	SCREW 4X10	
3-1-51	028040243	4	ハ"ネサ"カ"ネ2-4	SPRING WASHER 2-4	
3-1-52	028060243	2	ハ"ネサ"カ"ネ2-6	SPRING WASHER 2-6	
3-1-53	021060206	2	ナツト2シユ6	NUT 6	
3-1-54	S12297000	2	スポンジ"2-30	SPONGE 2-30	

S. 折曲ゲ関係 (特別注文部品)/Folding margin mechanism (Option parts)/Faltungsvorrichtung (Sonderzubehör)/
 Mécanisme de marge d'ourlet (Pièces en option)/Mecanismo de margen de plegado (Piezas a opción)

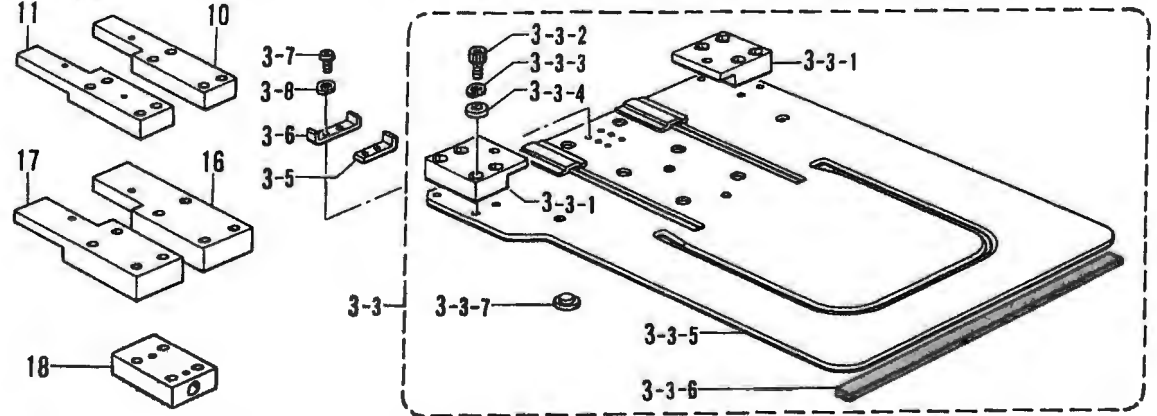
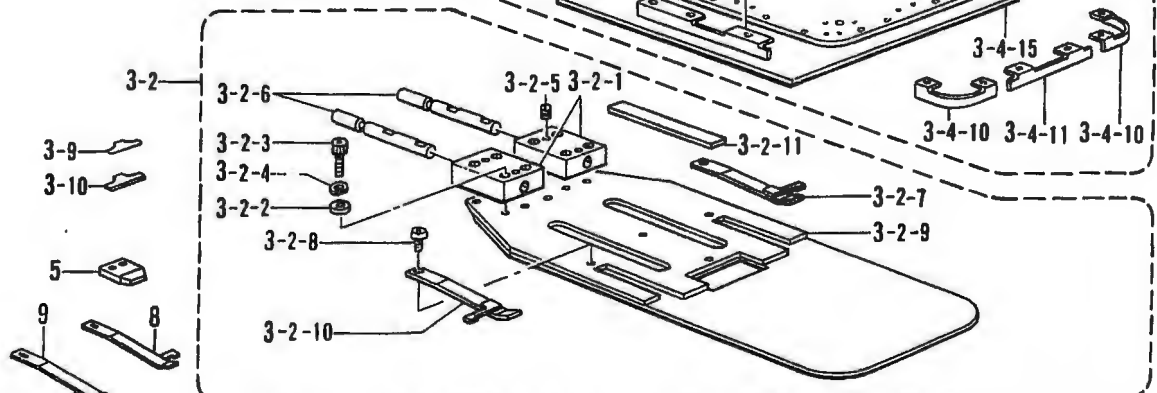
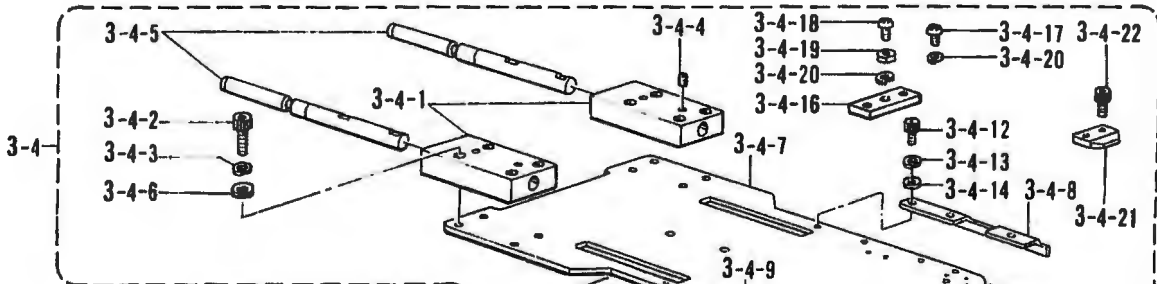
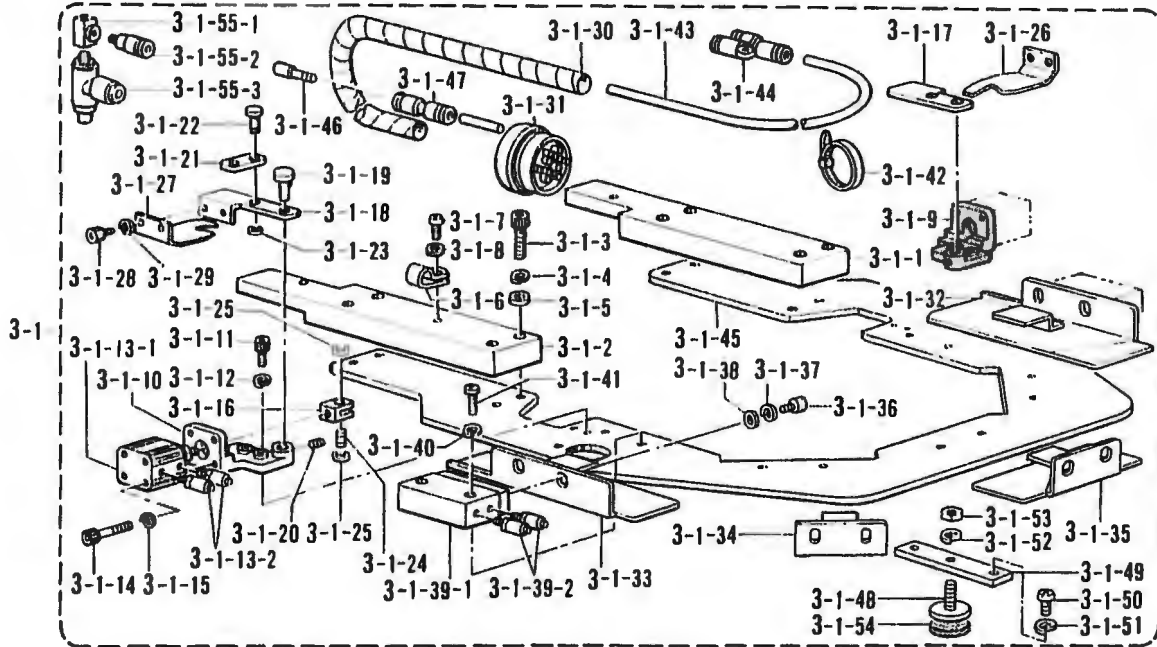

S. 折曲ゲ関係 (特別注文部品)/Folding margin mechanism (Option parts)/Faltungsvorrichtung (Sonderzubehör)/
 Mécanisme de marge d'ourlet (Pièces en option)/Mecanismo de margen de plegado (Piezas a opción)

REL NO	CODE	O'TY	ヒンメイ	NAME OF PARTS	RMKS
3 1 55	S15564000	1	チーM5クミ	T-M5 ASSEMBLY	
3 1 55 1	S15563000	1	チーM5	T M5	
3 1 55 2	S04905000	1	ハーフユニオン	HALF UNION	
3 1 55 3	S14328000	2	シホ"リハ"ン	THROTTLE VALVE	
3 2	S12330	1	ケ"ー"ジ"クミ"ー"マル	CENTER BLADE ASSEMBLY (ROUND)	
3 2 1	S12107001	2	コネク"フ"ロツク(ケ"ー"ジ")	CONNECT BLOCK (CENTER BLADE) (GAGE)	
3 2 2	025040232	8	ヒラサ"カ"ネチユウ4	PLAIN WASHER 4	
3 2 3	018402032	8	アナホ"ルト4X20	BOLT 4X20	
3 2 4	028040242	8	ハ"ネサ"カ"ネ2-4	SPRING WASHER 2-4	
3 2 5	014500522	4	アナトメネシ"5クホ"ミ	SET SCREW 5	
3 2 6	S12108001	2	コネク"ト"ピン(ケ"ー"ジ")	PIN (CENTER BLADE) (GAGE)	
3 2 7	S12109000	1	イ"タ"ハ"ネR	PLATE SPRING (R)	
3 2-8	060300414	2	ハ"イ"ン"ト"3X4	SCREW 3X4	
3 2 9	S12331	1	ケ"ー"ジ"ー"マル	CENTER BLADE (ROUND)	
3-2 10	S12105000	1	イ"タ"ハ"ネL	PLATE SPRING (L)	
3-2 11	S12278000	2	ウケイ"タ"(ケ"ー"ジ")	SUPPORT PLATE (CENTER BLADE) (GAGE)	
3-3	S12332	1	オ"サ"エ"ク"ミ"ー"マル	SEWING CLAMP ASSEMBLY (ROUND)	
3-3 1	S12110001	2	コネク"ト"フ"ロツク(オ"サ"エ)	CONNECT BLOCK (PRESSER)	
3-3-2	018401022	8	アナホ"ルト4X10	BOLT 4X10	
3-3-3	028040242	8	ハ"ネサ"カ"ネ2-4	SPRING WASHER 2-4	
3-3-4	025040232	8	ヒラサ"カ"ネチユウ4	PLAIN WASHER 4	
3-3-5	S12333	1	オ"サ"エ"ー"マル	SEWING CLAMP (ROUND)	
3-3-6	S12298000	2	フ"ォ"ー"ム3X15X1000	FORM 3X15X1000	
3-3-7	S12279000	6	ウケイ"タ"(オ"サ"エ)	SUPPORT PLATE (PRESSER)	
3-4	S12334	1	ナ"カ"オ"サ"エ"ク"ミ"ー"マル	INNER CLAMP ASSEMBLY (ROUND)	
3-4 1	S12113001	2	コネク"ト"フ"ロツク(ナ"カ)	CONNECT BLOCK (INNER)	
3-4-2	018502522	8	アナホ"ルト5X25	BOLT 5X25	
3-4-3	028050242	8	ハ"ネサ"カ"ネ2-5	SPRING WASHER 2-5	
3-4-4	014500522	4	アナトメネシ"5クホ"ミ	SET SCREW 5	
3-4-5	S12114001	2	コネク"ト"ピン(ナ"カ)	PIN (INNER)	
3-4-6	025050232	8	ヒラサ"カ"ネチユウ-5	PLAIN WASHER 5	
3-4-7	S12335	1	ナ"カ"オ"サ"エ"ー"マル	INNER CLAMP (ROUND)	
3-4-8	S12336	1	ナ"カ"オ"サ"エ"ウ"エ"1-ー"マル	INNER CLAMP UPPER 1 (ROUND)	
3-4-9	S12337	1	ナ"カ"オ"サ"エ"ウ"エ"2-ー"マル	INNER CLAMP UPPER 2 (ROUND)	
3-4-10	S12338	2	ナ"カ"オ"サ"エ"ウ"エ"3-ー"マル	INNER CLAMP UPPER 3 (ROUND)	
3-4-11	S12339	1	ナ"カ"オ"サ"エ"ウ"エ"4-ー"マル	INNER CLAMP UPPER 4 (ROUND)	
3-4-12	018300532	10	アナホ"ルト3X5	BOLT 3X5	
3-4-13	028030242	10	ハ"ネサ"カ"ネ2-3	SPRING WASHER 2-3	
3-4-14	025030232	10	ヒラサ"カ"ネチユウ3	PLAIN WASHER 3	
3-4-15	S12117000	1	フ"ォ"ー"ム2X200X200	FORM 2X200X200	
3-4-16	S12485001	2	ト"リ"ツ"ク"イ"タ"(ナ"カ"オ"サ"エ)	FITTING PLATE (INNER CLAMP)	
3-4-17	062400806	4	ナ"ハ"コ4X8	SCREW 4X8	
3-4-18	062401416	2	ナ"ハ"コ4X14	SCREW 4X14	
3-4-19	021400103	2	ナ"ツ"ト1シユ4	NUT 4	
3-4-20	028040243	6	ハ"ネサ"カ"ネ2-4	SPRING WASHER 2-4	
3-4-21	S12487000	5	オ"リ"イ"タ"ウ"ケ"(ナ"カ"オ"サ"エ)	FOLDING PLATE SUPPORT (INNER CLAMP)	
3-4-22	018300532	10	アナホ"ルト3X5	BOLT 3X5	
3-5	S12111001	3	ス"リ"ツ"トC	SLIT (C)	
3-6	S12112001	3	ス"リ"ツ"トD	SLIT (D)	
3-7	062300502	6	ナ"ハ"コ3X5	SCREW 3X5	
3-8	028030242	6	ハ"ネサ"カ"ネ2-3	SPRING WASHER 2-3	
3-9	S16514000	2	ス"パ"ー"サ"0.05	SPACER 0.05	
3-10	S16513000	2	ス"パ"ー"サ"0.1	SPACER 0.1	
5	S12494000	1	オ"リ"イ"タ"ウ"ケ"シ"ョ"ウ	FOLDING PLATE SUPPORT (SMALL)	
8	S15565000	1	イ"タ"ハ"ネR0.8	PLATE SPRING (R) 0.8	
9	S15566000	1	イ"タ"ハ"ネL0.8	PLATE SPRING (L) 0.8	
10	S12507001	1	コネク"ト"フ"ロツクSR	CONNECT BLOCK (SR)	
11	S12508001	1	コネク"ト"フ"ロツクSL	CONNECT BLOCK (SL)	
16	S21121001	1	コネク"ト"フ"ロツクSSR	CONNECT BLOCK (SSR)	
17	S21122001	1	コネク"ト"フ"ロツクSSL	CONNECT BLOCK (SSL)	
18	S21123001	2	コネク"ト"フ"ロツクS	CONNECT BLOCK (S)	

S. 折曲関係 (特別注文部品)/Folding margin mechanism (Option parts)/Faltungsvorrichtung (Sonderzubehör)/
 Mécanisme de marge d'ourlet (Pièces en option)/Mecanismo de margen de plegado (Piezas a opción)

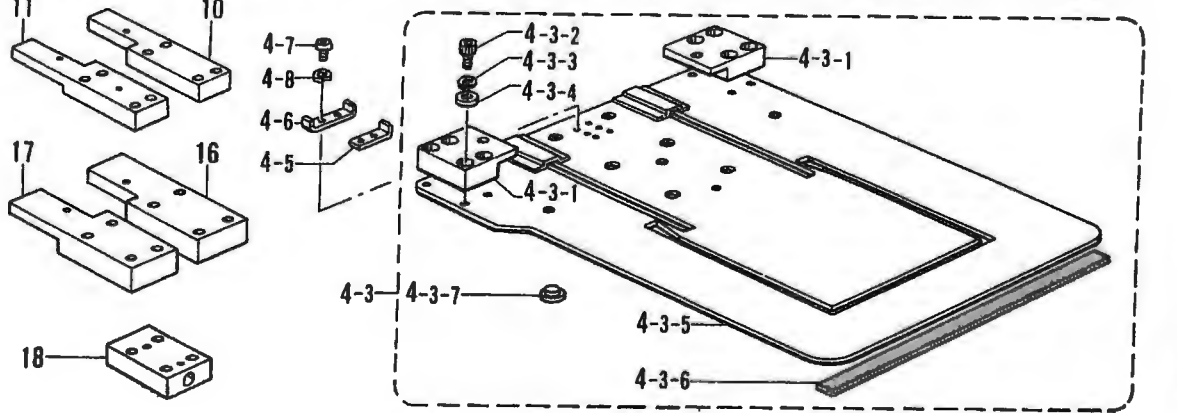
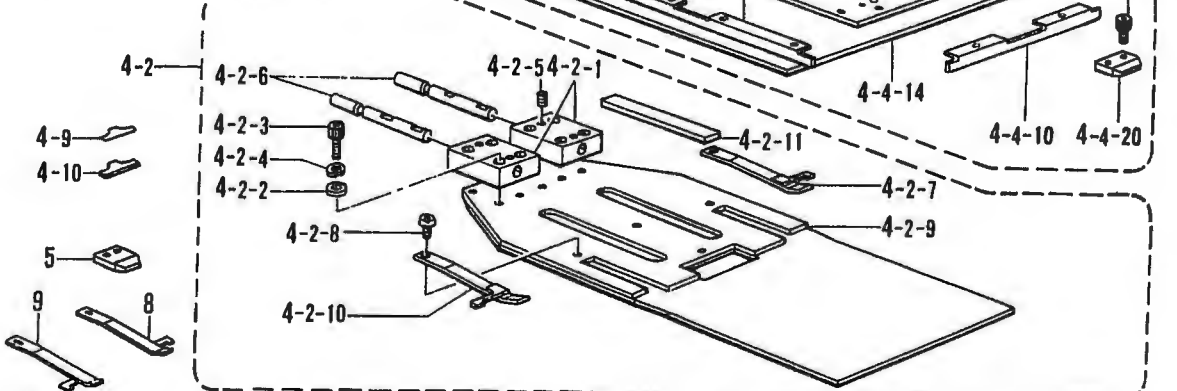
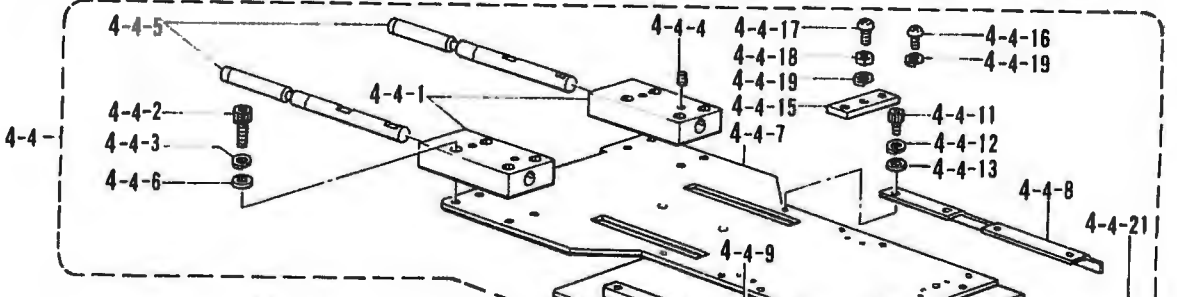
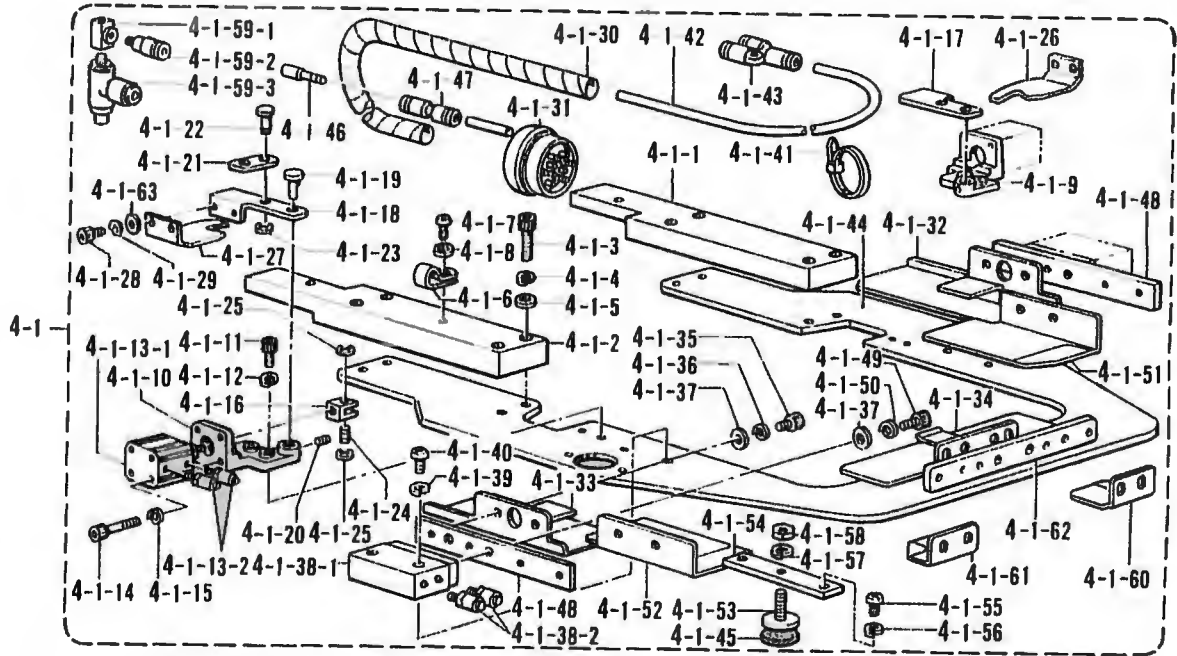

S. 折曲ゲ関係 (特別注文部品)/Folding margin mechanism (Option parts)/Faltungsvorrichtung (Sonderzubehör)/
 Mécanisme de marge d'ourlet (Pièces en option)/Mecanismo de margen de plegado (Piezas a opción)

REF NO	CODF	QTY	ヒンメイ	NAME OF PARTS	RMKS
4	S12341	1	オリキクミ-4カク	FOLDING GROUP ASSEMBLY (SQUARE)	
4 1	S12342	1	オリササエクミ-4カク	FOLDING CLAMP ASSEMBLY (SQUARE)	
4 1 1	S12086001	1	コネクタブ"ロツクR	CONNECT BLOCK (R)	
4 1 2	S12087001	1	コネクタブ"ロツクL	CONNECT BLOCK (L)	
4 1 3	018502522	8	アナホ"ルト5X25	BOLT 5X25	
4 1 4	028050242	8	ハ"ネサ"カ"ネ2-5	SPRING WASHER 2-5	
4 1 5	025050232	8	ヒラサ"カ"ネチユウ-5	PLAIN WASHER 5	
4 1 6	525907000	1	コード"ホルタ"9N	CORD HOLDER 9N	
4 1 7	062401006	1	ナヘ"コ4X10	SCREW 4X10	
4 1 8	025040233	1	ヒラサ"カ"ネチユウ4	PLAIN WASHER 4	
4 1 9	S12088009	1	レバ"ー"ヘ"ースR	LEVER BASE (R)	
4 1 10	S12089009	1	レバ"ー"ヘ"ースL	LEVER BASE (L)	
4 1 11	018401222	4	アナホ"ルト4X12	BOLT 4X12	
4 1 12	028040242	4	ハ"ネサ"カ"ネ2-4	SPRING WASHER 2-4	
4 1 13	S12090000	2	シリンダ"ー"12X10クミ	CYLINDER 12X10 ASSEMBLY	
4 1 13 1	S12091000	2	シリンダ"ー"12X10	CYLINDER 12X10	
4 1 13 2	S11433000	4	ホースニツプ"ル4M5	HOSE NIPPLE 4M5	
4 1 14	S12092000	8	CQ2ホ"ルトM3X30	CQ2 BOLT M3X30	
4 1 15	028030243	8	ハ"ネサ"カ"ネ2-3	SPRING WASHER 2-3	
4 1 16	S12093001	2	ナツクル	KNUCKLE	
4 1 17	S12094001	1	ヒンジ"R	HINGE (R)	
4 1 18	S12095001	1	ヒンジ"L	HINGE (L)	
4 1 19	S12096001	2	ヒンジ"ピン	PIN	
4 1 20	014400522	2	アナクホ"ミ4X5	SET SCREW 4X5	
4 1 21	S12097001	2	タイフ"レート	TIE PLATE	
4 1 22	S12098001	2	ピン	PIN	
4 1 23	048050342	2	トメフE5	STOP RING E5	
4 1 24	S12099001	2	ナツクル"ピン	PIN	
4 1 25	048050342	4	トメフE5	STOP RING E5	
4 1 26	S12475100	1	メントリイタR"タイ	TUCKING BLADE (R) LARGE	
4 1 27	S12476100	1	メントリイタL"タイ	TUCKING BLADE (L) LARGE	
4 1 28	018400632	4	アナホ"ルト4X6	BOLT 4X6	
4 1 29	028040242	4	ハ"ネサ"カ"ネ2-4	SPRING WASHER 2-4	
4 1 30	S12214000	1	スパイラル640L	SPIRAL 640L	
4 1 31	S12106000	1	マルチコネクタP	MULTI CONNECTOR (P)	
4 1 32	S12343---	1	オリイタR-4カク	TUCKING BLADE (R) (SQUARE)	
4 1 33	S12344---	1	オリイタL-4カク	TUCKING BLADE (L) (SQUARE)	
4 1 34	S12345---	1	オリイタD-4カク	TUCKING BLADE (D) (SQUARE)	
4 1 35	018400632	14	アナホ"ルト4X6	BOLT 4X6	
4 1 36	028040242	14	ハ"ネサ"カ"ネ2-4	SPRING WASHER 2-4	
4 1 37	025040232	18	ヒラサ"カ"ネチユウ4	PLAIN WASHER 4	
4 1 38	S12102000	3	ツインロツト"シリンダ"ークミ	TWIN ROD CYLINDER ASSEMBLY	
4 1 38-1	S12103000	3	ツインロツト"シリンダ"ー	TWIN ROD CYLINDER	
4 1 38-2	S11433000	6	ホースニツプ"ル4M5	HOSE NIPPLE 4M5	
4 1 39	028040243	6	ハ"ネサ"カ"ネ2-4	SPRING WASHER 2-4	
4 1 40	062402016	6	ナヘ"コM4X20	SCREW M4X20	
4 1 41	S04159000	2	バンド"1M	BAND 1M	
4 1 42	S12205000	1	エアホース4X2.5-29	AIR TUBE 4X2.5-29 (L=7500)	
4 1 43	S12104000	4	ユニオン"ワイ4	UNION-Y 4	
4 1 44	S12346---	1	オリササエ-4カク	FOLDING CLAMP (SQUARE)	
4 1 45	S12297000	2	スホ"ンシ"2-30	SPONGE 2-30	
4 1 46	S04897000	2	メクラ"セン	BLIND CAP	
4 1 47	S04587000	2	ストレート"ツキ"テ	STRAIGHT JOINT	
4 1 48	S12469---	2	オリイタササエ-4カク	FOLDING PLATE SUPPORT (SQUARE)	
4 1 49	018400832	6	アナホ"ルト4X8	BOLT 4X8	
4 1 50	028040242	6	ハ"ネサ"カ"ネ2-4	SPRING WASHER 2-4	
4 1 51	S12470---	1	オリイタRD-4カク	TUCKING BLADE (RD) (SQUARE)	
4 1 52	S12471---	1	オリイタLD-4カク	TUCKING BLADE (LD) (SQUARE)	
4 1 53	S12291001	2	アジ"ヤストネジ"	ADJUST SCREW	
4 1 54	S12294001	2	トリツクイ"タ(オリササエ)	FITTING PLATE (FOLDING CLAMP)	
4 1 55	062401006	4	ナヘ"コ4X10	SCREW 4X10	
4 1 56	028040243	4	ハ"ネサ"カ"ネ2-4	SPRING WASHER 2-4	

S. 折曲メ関係 (特別注文部品)/Folding margin mechanism (Option parts)/Faltungsvorrichtung (Sonderzubehör)/
 Mécanisme de marge d'ourlet (Pièces en option)/Mecanismo de margen de plegado (Piezas a opción)

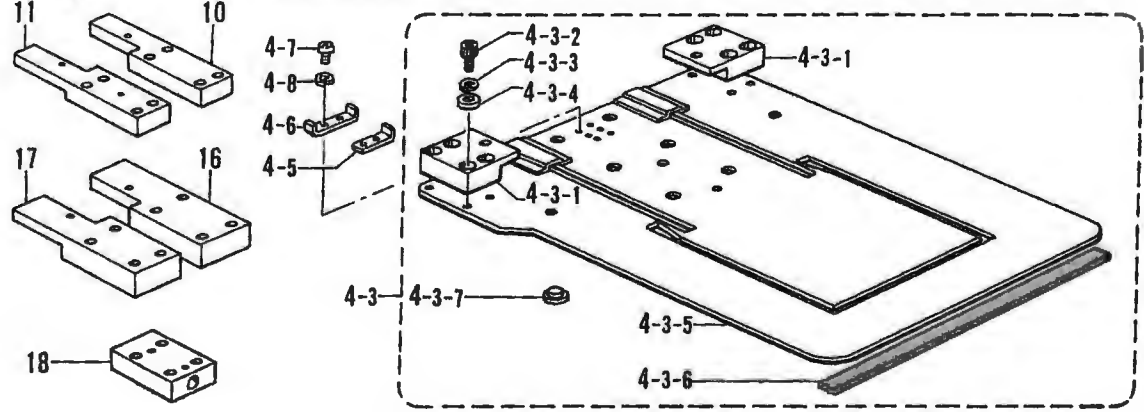
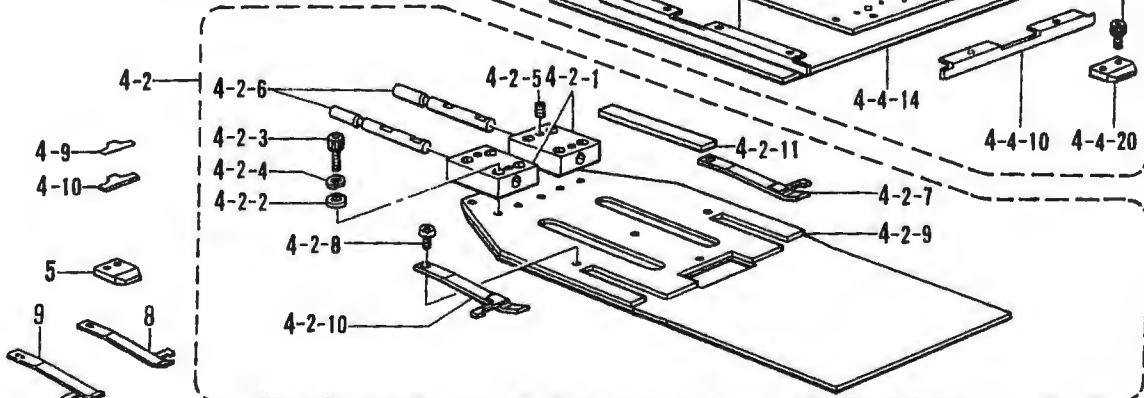
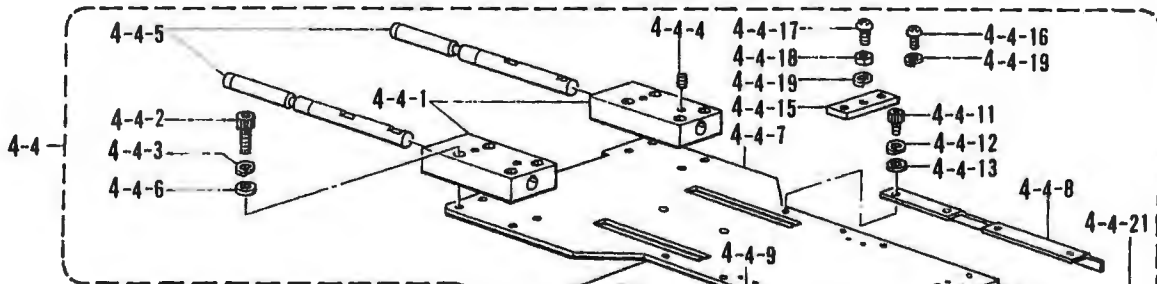
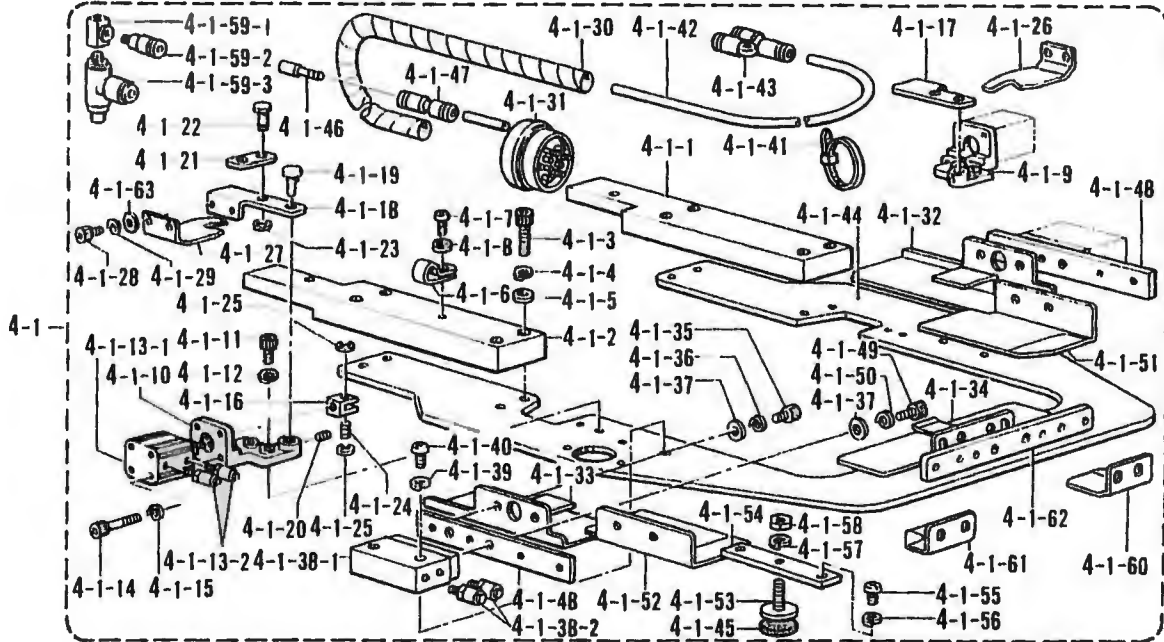

S. 折曲ゲ関係 (特別注文部品)/Folding margin mechanism (Option parts)/Faltungsvorrichtung (Sonderzubehör)/
 Mécanisme de marge d'ourlet (Pièces en option)/Mecanismo de margen de plegado (Piezas a opción)

RCI NO	CODR	Q'TY	ヒンメイ	NAME OF PARTS	RMKS
4 1 57	028060243	2	ハ"ネサ"カ"ネ2-6	SPRING WASHER 2-6	
4 1 58	021060206	2	ナツト2シユ6	NUT 6	
4 1 59	S15564000	1	チ-M5クミ	T-M5 ASSEMBLY	
4 1 59 1	S15563000	1	チ-M5	T M5	
4 1 59 2	S04905000	1	ハーフユニオン	HALF UNION	
4 1 59 3	S14328000	2	シホ"リハ"ン	THROTTLE VALVE	
4 1 60	S16515	1	オリイタRDD-4カク	TUCKING BLADE (RDD) (SQUARE)	
4-1-61	S16516	1	オリイタLDD-4カク	TUCKING BLADE (LDD) (SQUARE)	
4 1 62	S16517	1	オリイタサID-4カク	TUCKING BLADE SUPPORT (D) (SQUARE)	
4 1 63	025040132	6	ヒラサ"カ"ネシヨウ4	PLAIN WASHER 4	
4-2	S12347	1	ケ"ージ"クミ-4カク	CENTER BLADE ASSEMBLY (SQUARE)	
4-2 1	S12107001	2	コネクタブ"ロツク(ケ"ージ")	CONNECT BLOCK (CENTER BLADE) (GAGE)	
4-2 2	025040232	8	ヒラサ"カ"ネチユウ4	PLAIN WASHER 4	
4 2 3	018402032	8	アナホ"ルト4X20	BOLT 4X20	
4-2 4	028040242	8	ハ"ネサ"カ"ネ2-4	SPRING WASHER 2-4	
4-2 5	014500522	4	アナトメネシ"5クホ"ミ	SET SCREW 5	
4-2-6	S12108001	2	コネクトピン(ケ"ージ")	PIN (CENTER BLADE) (GAGE)	
4 2 7	S12109000	1	イタハ"ネR	PLATE SPRING (R)	
4-2 8	060300414	2	ハ"イント"3X4	SCREW 3X4	
4-2 9	S12348---	1	ケ"ージ"-4カク	CENTER BLADE (SQUARE)	
4-2 10	S12105000	1	イタハ"ネL	PLATE SPRING (L)	
4-2 11	S12278000	2	ウケイタ(ケ"ージ")	SUPPORT PLATE (CENTER BLADE) (GAGE)	
4-3	S12349---	1	オサエクミ-4カク	SEWING CLAMP ASSEMBLY (SQUARE)	
4-3-1	S12110001	2	コネクタブ"ロツク(オサエ)	CONNECT BLOCK (PRESSER)	
4-3-2	018401022	8	アナホ"ルト4X10	BOLT 4X10	
4-3-3	028040242	8	ハ"ネサ"カ"ネ2-4	SPRING WASHER 2-4	
4-3-4	025040232	8	ヒラサ"カ"ネチユウ4	PLAIN WASHER 4	
4-3-5	S12350---	1	オサエ-4カク	SEWING CLAMP (SQUARE)	
4-3-6	S12298000	2	フォーム3X15X1000	FORM 3X15X1000	
4-3-7	S12279000	6	ウケイタ(オサエ)	SUPPORT PLATE (PRESSER)	
4-4	S12351---	1	ナカオサエクミ-4カク	INNER CLAMP ASSEMBLY (SQUARE)	
4-4-1	S12113001	2	コネクタブ"ロツク(ナカ)	CONNECT BLOCK (INNER)	
4-4-2	018502522	8	アナホ"ルト5X25	BOLT 5X25	
4-4-3	028050242	8	ハ"ネサ"カ"ネ2-5	SPRING WASHER 2-5	
4-4-4	014500522	4	アナトメネシ"5クホ"ミ	SET SCREW 5	
4-4-5	S12114001	2	コネクトピン(ナカ)	PIN (INNER)	
4-4-6	025050232	8	ヒラサ"カ"ネチユウ-5	PLAIN WASHER 5	
4-4-7	S12352---	1	ナカオサエ-4カク	INNER CLAMP (SQUARE)	
4-4-8	S12353---	1	ナカオサエウエ1-4カク	INNER CLAMP UPPER 1 (SQUARE)	
4-4-9	S12354---	1	ナカオサエウエ2-4カク	INNER CLAMP UPPER 2 (SQUARE)	
4-4-10	S12355---	1	ナカオサエウエ3-4カク	INNER CLAMP UPPER 3 (SQUARE)	
4-4-11	018300532	6	アナホ"ルト3X5	BOLT 3X5	
4-4-12	028030242	6	ハ"ネサ"カ"ネ2-3	SPRING WASHER 2-3	
4-4-13	025030232	6	ヒラサ"カ"ネチユウ3	PLAIN WASHER 3	
4-4-14	S12117000	1	フォーム2X200X200	FORM 2X200X200	
4-4-15	S12485001	2	トリツケイタ(ナカオサエ)	FITTING PLATE (INNER CLAMP)	
4-4-16	062400806	4	ナヘ"コ4X8	SCREW 4X8	
4-4-17	062401416	2	ナヘ"コ4X14	SCREW 4X14	
4-4-18	021400103	2	ナツト1シユ4	NUT 4	
4-4-19	028040243	6	ハ"ネサ"カ"ネ2-4	SPRING WASHER 2-4	
4-4-20	S12487000	3	オリイタウケ(ナカオサエ)	FOLDING PLATE SUPPORT (INNER CLAMP)	
4-4-21	018300532	6	アナホ"ルト3X5	BOLT 3X5	
4-5	S12111001	3	スリットC	SLIT (C)	
4-6	S12112001	3	スリットD	SLIT (D)	
4-7	062300502	6	ナヘ"コ3X5	SCREW 3X5	
4-8	028030242	6	ハ"ネサ"カ"ネ2-3	SPRING WASHER 2-3	
4-9	S16514000	2	スヘ"ーサ0.05	SPACER 0.05	
4-10	S16513000	2	スヘ"ーサ0.1	SPACER 0.1	
5	S12494000	1	オリイタウケシヨウ	FOLDING PLATE SUPPORT (SMALL)	
8	S15565000	1	イタハ"ネR0.8	PLATE SPRING (R) 0.8	
9	S15566000	1	イタハ"ネL0.8	PLATE SPRING (L) 0.8	
10	S12507001	1	コネクタブ"ロツクSR	CONNECT BLOCK (SR)	

S. 折曲ヶ関係 (特別注文部品)/Folding margin mechanism (Option parts)/Faltungsvorrichtung (Sonderzubehör)/
 Mécanisme de marge d'ourlet (Pièces en option)/Mecanismo de margen de plegado (Piezas a opción)

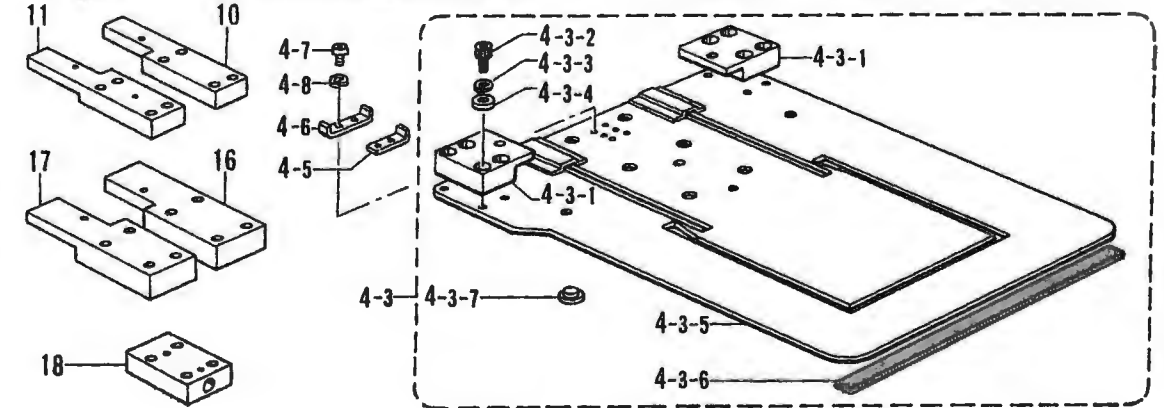
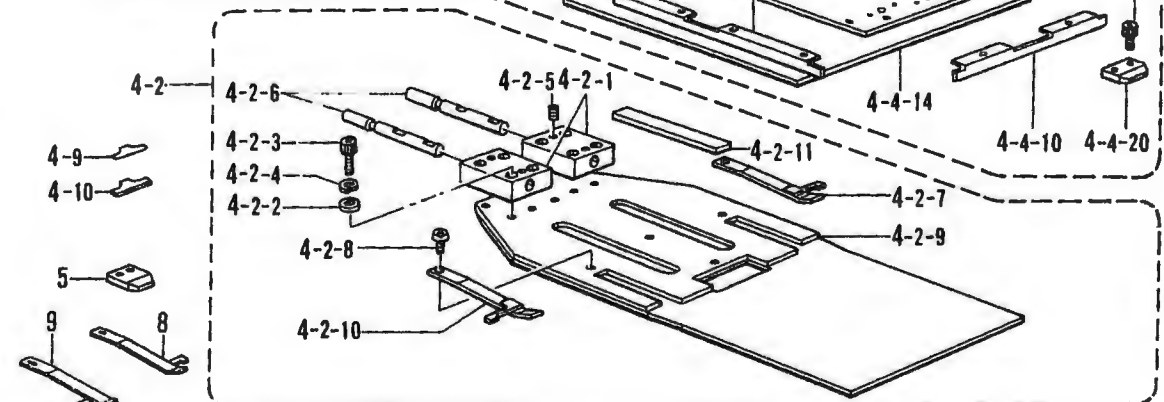
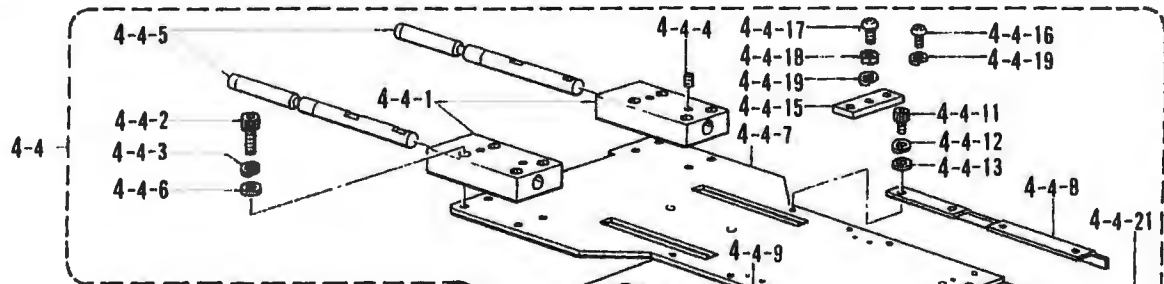
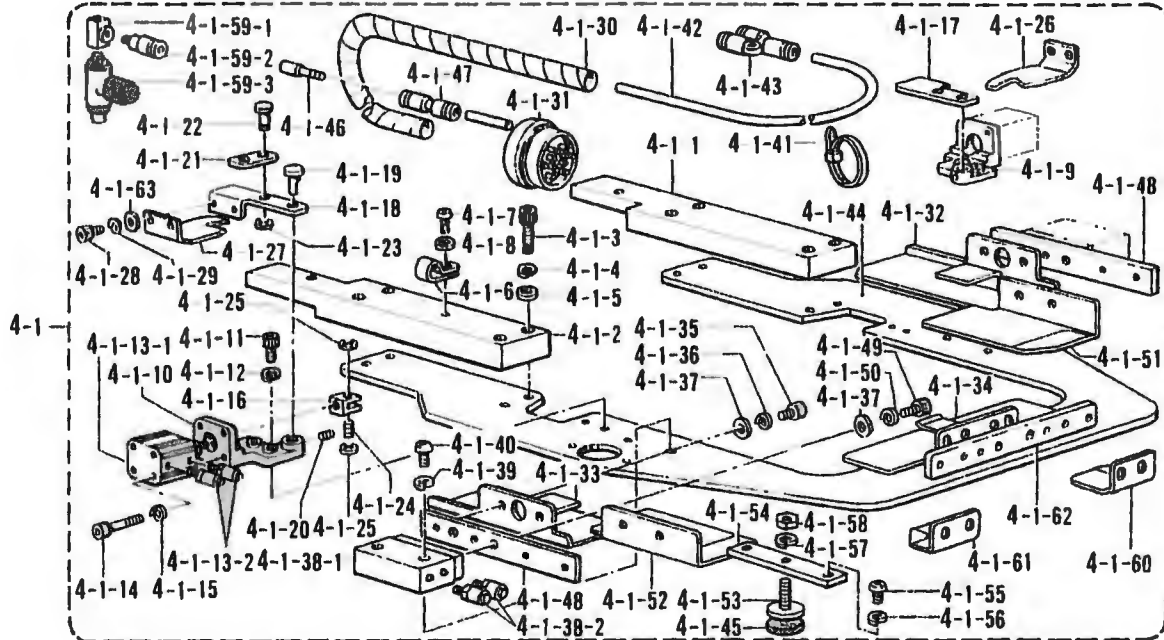

S. 折曲げ関係 (特別注文部品)/Folding margin mechanism (Option parts)/Faltungsvorrichtung (Sonderzubehör)/
 Mécanisme de marge d'ourlet (Pièces en option)/Mecanismo de margen de plegado (Piezas a opción)

REI NO	CODE	Q'TY	品名	NAME OF PARTS	RMKS
11	S12508001	1	コネクタブロックSL	CONNECT BLOCK (SL)	
16	S21121001	1	コネクタブロックSSR	CONNECT BLOCK (SSR)	
17	S21122001	1	コネクタブロックSSL	CONNECT BLOCK (SSL)	
18	S21123001	2	コネクタブロックS	CONNECT BLOCK (S)	

S. 折曲ゲ関係 (特別注文部品)/Folding margin mechanism (Option parts)/Faltungsvorrichtung (Sonderzubehör)/
 Mécanisme de marge d'ourlet (Pièces en option)/Mecanismo de margen de plegado (Piezas a opción)

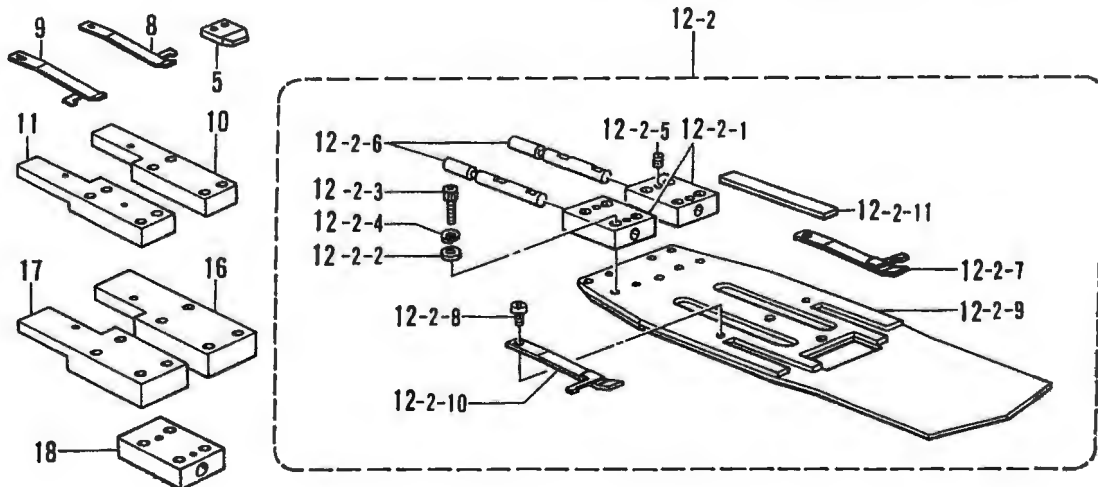
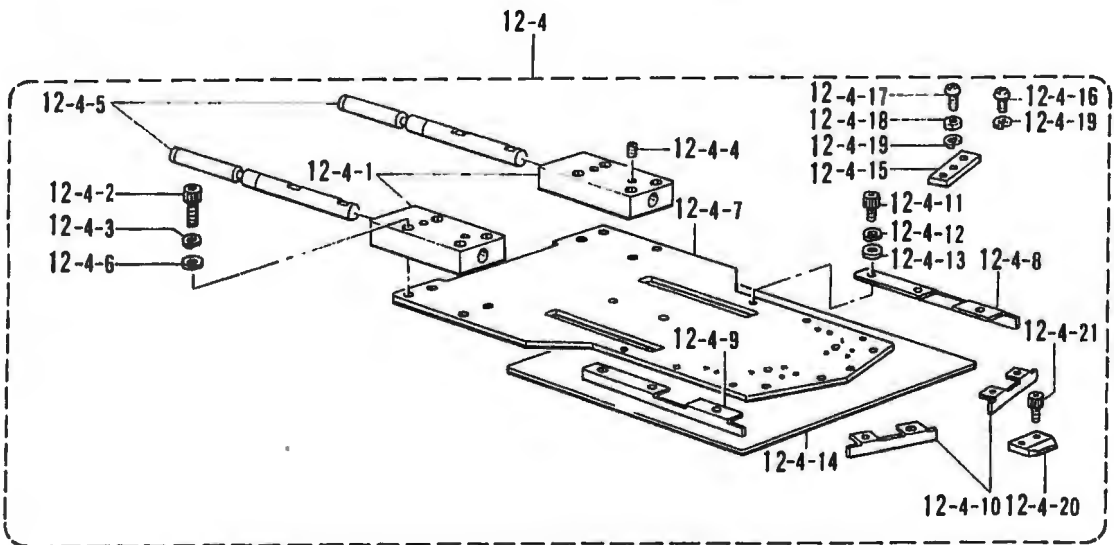
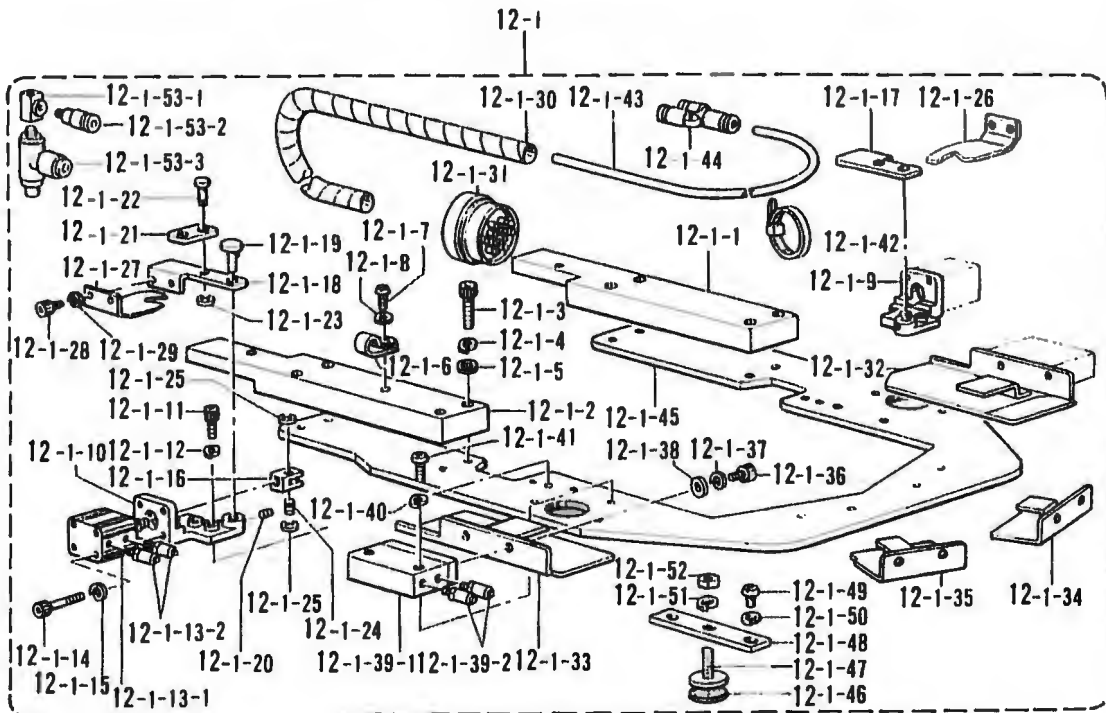

5. 折曲ケ関係 (特別注文部品)/Folding margin mechanism (Option parts)/Faltungsvorrichtung (Sonderzubehör)/
Mécánisme de marge d'ourlet (Pièces en option)/Mecanismo de margen de plegado (Piezas a opción)

REF NO	CODE	Q'TY	品名	NAME OF PARTS	RMKS
12	S19561---	1	オリキクミ-3カク2	FOLDING GROUP ASSEMBLY (TRIANGLE-2)	
12-1	S12284---	1	オリササエクミ-3カク	FOLDING CLAMP ASSEMBLY (TRIANGLE)	
12-1-1	S12086001	1	コネクトフ"ロツクR	CONNECT BLOCK (R)	
12-1-2	S12087001	1	コネクトフ"ロツクL	CONNECT BLOCK (L)	
12-1-3	018502522	8	アナホ"ルト5X25	BOLT 5X25	
12-1-4	028050242	8	ハ"ネサ"カ"ネ2-5	SPRING WASHER 2-5	
12-1-5	025050232	8	ヒラサ"カ"ネチユウ-5	PLAIN WASHER 5	
12-1-6	525907000	1	コート"ホルタ"9N	CORD HOLDER 9N	
12-1-7	062401006	1	ナヘ"コ4X10	SCREW 4X10	
12-1-8	025040233	1	ヒラサ"カ"ネチユウ4	PLAIN WASHER 4	
12-1-9	S12088009	1	レバ"ー"ヘ"ースR	LEVER BASE (R)	
12-1-10	S12089009	1	レバ"ー"ヘ"ースL	LEVER BASE (L)	
12-1-11	018401222	4	アナホ"ルト4X12	BOLT 4X12	
12-1-12	028040242	4	ハ"ネサ"カ"ネ2-4	SPRING WASHER 2-4	
12-1-13	S12090000	2	シリンダ"ー12X10クミ	CYLINDER 12X10 ASSEMBLY	
12-1-13-1	S12091000	2	シリンダ"ー12X10	CYLINDER 12X10	
12-1-13-2	S11433000	4	ホースニツフ"ル4M5	HOSE NIPPLE 4M5	
12-1-14	S12092000	8	CQ2ホ"ルトM3X30	CQ2 BOLT M3X30	
12-1-15	028030243	8	ハ"ネサ"カ"ネ2-3	SPRING WASHER 2-3	
12-1-16	S12093001	2	ナツクル	KNUCKLE	
12-1-17	S12094001	1	ヒンジ"R	HINGE (R)	
12-1-18	S12095001	1	ヒンジ"L	HINGE (L)	
12-1-19	S12096001	2	ヒンジ"ピン	PIN	
12-1-20	014400522	2	アナクホ"ミ4X5	SET SCREW 4X5	
12-1-21	S12097001	2	タイフ"レート	TIE PLATE	
12-1-22	S12098001	2	ピン	PIN	
12-1-23	048050342	2	トメフE5	STOP RING E5	
12-1-24	S12099001	2	ナツクル"ピン	PIN	
12-1-25	048050342	4	トメフE5	STOP RING E5	
12-1-26	S12475100	1	メントリイタR"タイ	TUCKING BLADE (R) LARGE	
12-1-27	S12476100	1	メントリイタL"タイ	TUCKING BLADE (L) LARGE	
12-1-28	018400632	4	アナホ"ルト4X6	BOLT 4X6	
12-1-29	028040242	4	ハ"ネサ"カ"ネ2-4	SPRING WASHER 2-4	
12-1-30	S12214000	1	スパイラル640L	SPIRAL 640L	
12-1-31	S12106000	1	マルチコネクタP	MULTI CONNECTOR (P)	
12-1-32	S12285---	1	オリイタR-3カク	TUCKING BLADE (R) (TRIANGLE)	
12-1-33	S12286---	1	オリイタL-3カク	TUCKING BLADE (L) (TRIANGLE)	
12-1-34	S12287---	1	オリイタRD-3カク	TUCKING BLADE (RD) (TRIANGLE)	
12-1-35	S12288---	1	オリイタLD-3カク	TUCKING BLADE (LD) (TRIANGLE)	
12-1-36	018400632	8	アナホ"ルト4X6	BOLT 4X6	
12-1-37	028040242	8	ハ"ネサ"カ"ネ2-4	SPRING WASHER 2-4	
12-1-38	025040232	12	ヒラサ"カ"ネチユウ4	PLAIN WASHER 4	
12-1-39	S12102000	4	ツインロツト"シリンダ"クミ	TWIN ROD CYLINDER ASSEMBLY	
12-1-39-1	S12103000	4	ツインロツト"シリンダ"	TWIN ROD CYLINDER	
12-1-39-2	S11433000	8	ホースニツフ"ル4M5	HOSE NIPPLE 4M5	
12-1-40	028040243	8	ハ"ネサ"カ"ネ2-4	SPRING WASHER 2-4	
12-1-41	062402016	8	ナヘ"コM4X20	SCREW M4X20	
12-1-42	S04159000	3	バンド"1M	BAND 1M	
12-1-43	S12205000	1	エアホース4X2.5-29	AIR TUBE 4X2.5-29 (L=7500)	
12-1-44	S12104000	6	ユニオンワイ4	UNION-Y 4	
12-1-45	S12289---	1	オリササエ-3カク	FOLDING CLAMP (TRIANGLE)	
12-1-46	S12297000	2	スポンジ"2-30	SPONGE 2-30	
12-1-47	S12291001	2	アジ"ヤストネジ"	ADJUST SCREW	
12-1-48	S12294001	2	トリツケイタ(オリササエ)	FITTING PLATE (FOLDING CLAMP)	
12-1-49	062401006	4	ナヘ"コ4X10	SCREW 4X10	
12-1-50	028040243	4	ハ"ネサ"カ"ネ2-4	SPRING WASHER 2-4	
12-1-51	028060243	2	ハ"ネサ"カ"ネ2-6	SPRING WASHER 2-6	
12-1-52	021060206	2	ナツト2シユ6	NUT 6	
12-1-53	S15564000	1	チ-M5クミ	T-M5 ASSEMBLY	
12-1-53-1	S15563000	1	チ-M5	T-M5	
12-1-53-2	S04905000	1	ハーフユニオン	HALF UNION	
12-1-53-3	S14328000	2	シホ"リハ"ン	THROTTLE VALVE	

S. 折曲ゲ関係 (特別注文部品)/Folding margin mechanism (Option parts)/Faltungsvorrichtung (Sonderzubehör)/
 Mécanisme de marge d'ourlet (Pièces en option)/Mecanismo de margen de plegado (Piezas a opción)

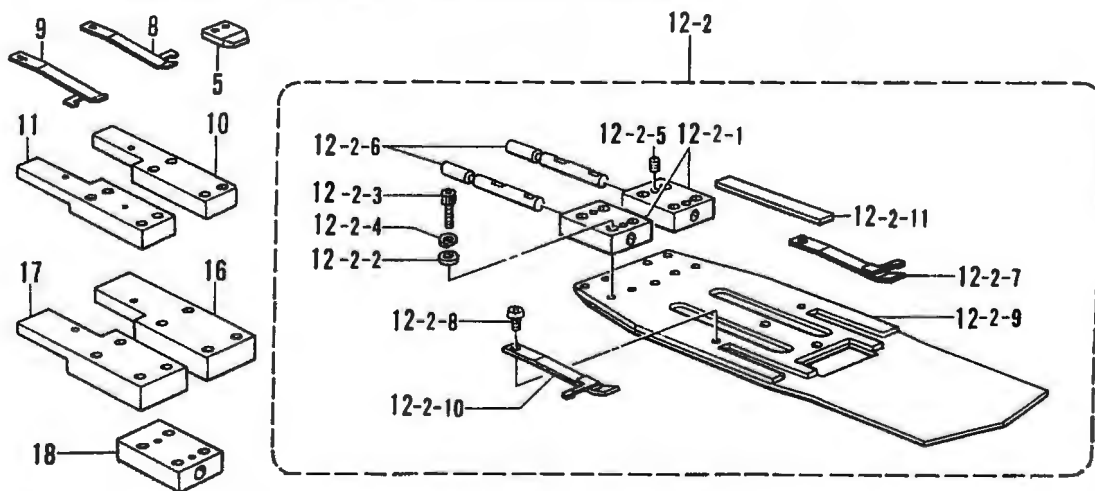
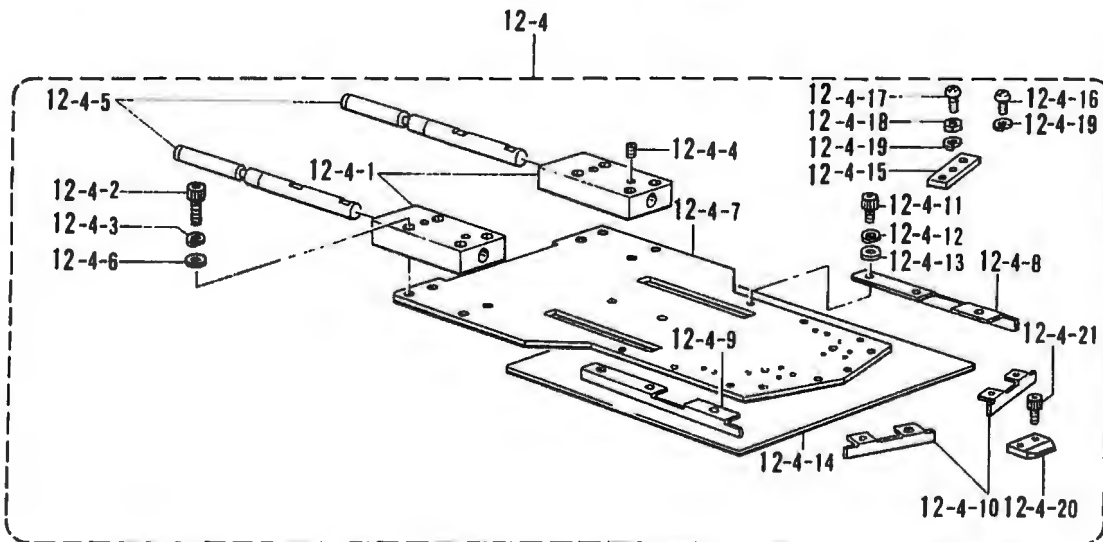
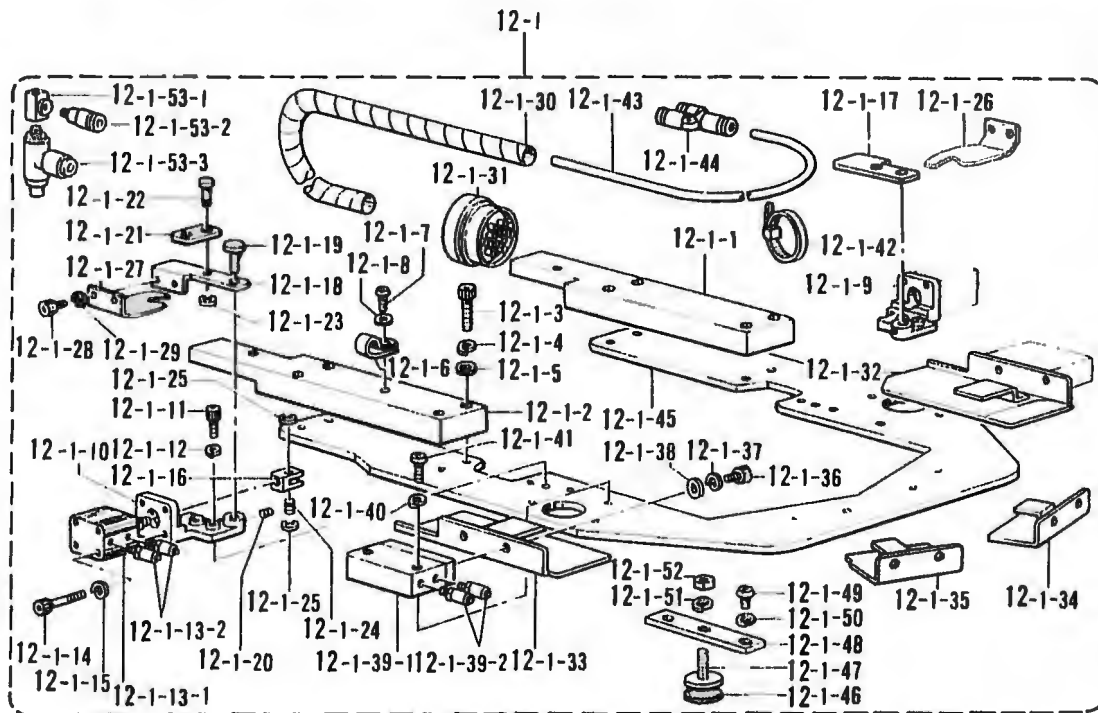

S. 折曲ゲ関係 (特別注文部品)/Folding margin mechanism (Option parts)/Faltungsvorrichtung (Sonderzubehör)/
 Mécanisme de marge d'ourlet (Pièces en option)/Mecanismo de margen de plegado (Piezas a opción)

REF NO	CODE	Q'TY	ヒンメイ	NAME OF PARTS	RMKS
12 2	S12292	1	ク-シ"クミ-3カク	CENTER BLADE ASSEMBLY (TRIANGLE)	
12 2 1	S12107001	2	コネクトフ"ロツク(ク-シ")	CONNECT BLOCK (CENTER BLADE) (GAGE)	
12 2 2	025040232	8	ヒラサ"カ"ネチユウ4	PLAIN WASHER 4	
12 2 3	018402032	8	アナホ"ルト4X20	BOLT 4X20	
12 2 4	028040242	8	ハ"ネサ"カ"ネ2-4	SPRING WASHER 2-4	
12 2 5	014500522	4	アナトメネシ"5クホ"ミ	SET SCREW 5	
12 2 6	S12108001	2	コネクトヒン(ク-シ")	PIN (CENTER BLADE) (GAGE)	
12 2 7	S12109000	1	イタハ"ネR	PLATE SPRING (R)	
12 2 8	060300414	2	ハ"イント"3X4	SCREW 3X4	
12 2 9	S12293	1	ク-シ"-3カク	CENTER BLADE (TRIANGLE)	
12 2 10	S12105000	1	イタハ"ネL	PLATE SPRING (L)	
12 2 11	S12278000	2	ウケイタ(ク-シ")	SUPPORT PLATE (CENTER BLADE) (GAGE)	
12-4	S12299	1	ナカオサイクミ-3カク	INNER CLAMP ASSEMBLY (TRIANGLE)	
12-4 1	S12113001	2	コネクトフ"ロツク(ナカ)	CONNECT BLOCK (INNER)	
12-4 2	018502522	8	アナホ"ルト5X25	BOLT 5X25	
12-4 3	028050242	8	ハ"ネサ"カ"ネ2-5	SPRING WASHER 2-5	
12-4 4	014500522	4	アナトメネシ"5クホ"ミ	SET SCREW 5	
12-4 5	S12114001	2	コネクトヒン(ナカ)	PIN (INNER)	
12-4 6	025050232	8	ヒラサ"カ"ネチユウ-5	PLAIN WASHER 5	
12-4 7	S12300--	1	ナカオサエ-3カク	INNER CLAMP (TRIANGLE)	
12-4 8	S12301--	1	ナカオサエウI1-3カク	INNER CLAMP BLADE-1 (TRIANGLE)	
12-4 9	S12302--	1	ナカオサエウI2-3カク	INNER CLAMP BLADE-2 (TRIANGLE)	
12-4 10	S12303--	2	ナカオサエウI3-3カク	INNER CLAMP BLADE-3 (TRIANGLE)	
12-4 11	018300532	8	アナホ"ルト3X5	BOLT 3X5	
12-4 12	028030242	8	ハ"ネサ"カ"ネ2-3	SPRING WASHER 2-3	
12-4 13	025030232	8	ヒラサ"カ"ネチユウ3	PLAIN WASHER 3	
12-4 14	S12117000	1	フォーム2X200X200	FORM 2X200X200	
12-4 15	S12485001	2	トリツケイタ(ナカオサエ)	FITTING PLATE (INNER CLAMP)	
12-4 16	062400806	4	ナヘ"コ4X8	SCREW 4X8	
12-4 17	062401416	2	ナヘ"コ4X14	SCREW 4X14	
12-4 18	021400103	2	ナツト1シユ4	NUT 4	
12-4 19	028040243	6	ハ"ネサ"カ"ネ2-4	SPRING WASHER 2-4	
12-4 20	S12487000	4	オリイタウケ(ナカオサエ)	FOLDING PLATE SUPPORT (INNER CLAMP)	
12-4 21	018300532	8	アナホ"ルト3X5	BOLT 3X5	
5	S12494000	1	オリイタウケシヨウ	FOLDING PLATE SUPPORT (SMALL)	
8	S15565000	1	イタハ"ネR0.8	PLATE SPRING (R) 0.8	
9	S15566000	1	イタハ"ネL0.8	PLATE SPRING (L) 0.8	
10	S12507001	1	コネクトフ"ロツクSR	CONNECT BLOCK (SR)	
11	S12508001	1	コネクトフ"ロツクSL	CONNECT BLOCK (SL)	
16	S21121001	1	コネクトフ"ロツクSSR	CONNECT BLOCK (SSR)	
17	S21122001	1	コネクトフ"ロツクSSL	CONNECT BLOCK (SSL)	
18	S21123001	2	コネクトフ"ロツクS	CONNECT BLOCK (S)	

S. 折曲ゲ関係 (特別注文部品)/Folding margin mechanism (Option parts)/Faltungsvorrichtung (Sonderzubehör)/
 Mécanisme de marge d'ourlet (Pièces en option)/Mecanismo de margen de plegado (Piezas a opción)

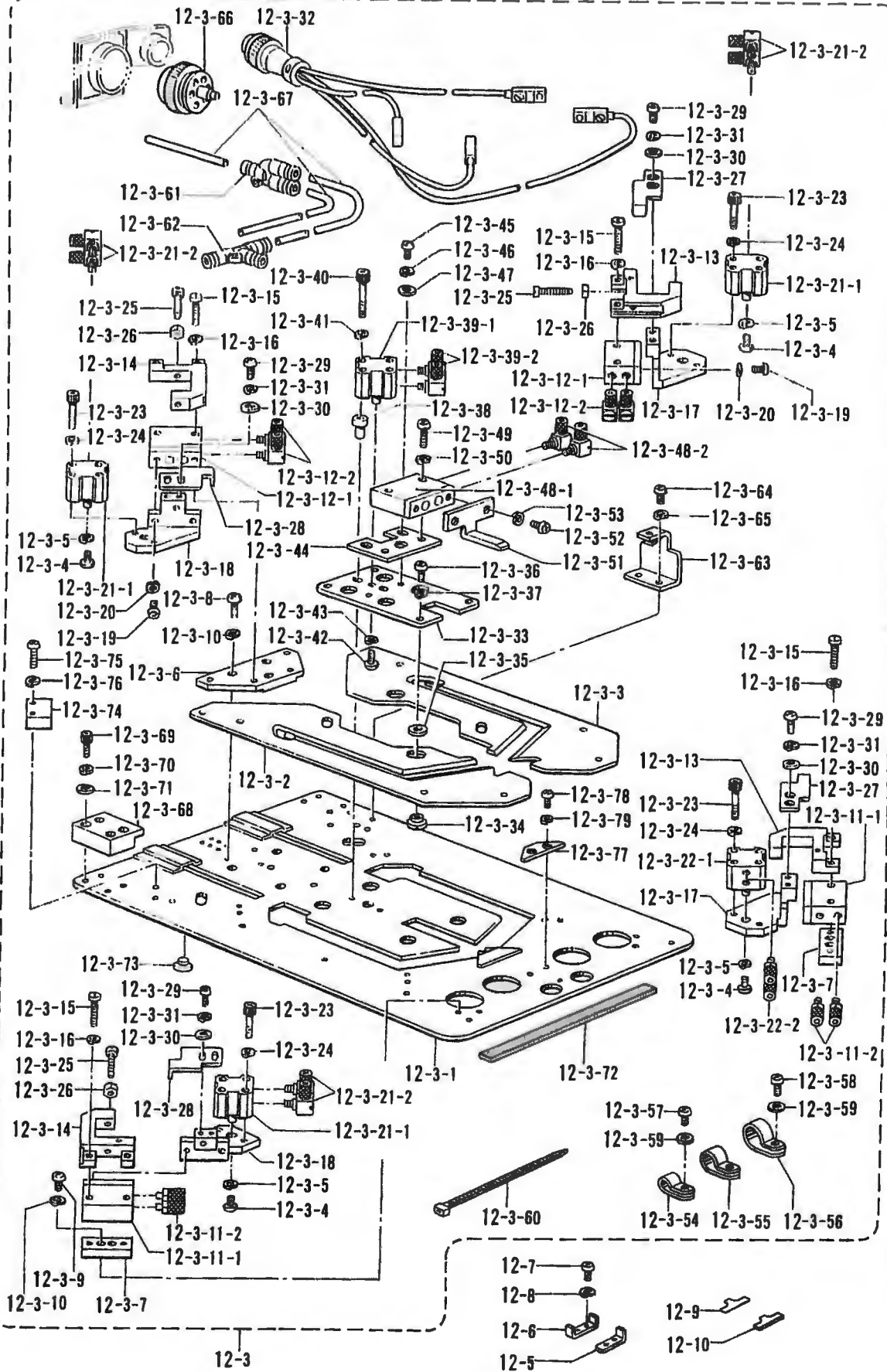

S. 折曲ゲ関係 (特別注文部品)/Folding margin mechanism (Option parts)/Faltungsvorrichtung (Sonderzubehör)/
Mecanismo de marge d'ourlet (Pièces en option)/Mecanismo de margen de plegado (Piezas a opción)

REF.NO	CODF	QTY	ヒンメイ	NAME OF PARTS	RMKS
12-3	S19669	1	オサイクミ-3カク2	SEWING CLAMP ASSEMBLY (TRIANGLE 2)	
12-3-1	S19562	1	オサエシター-3カク2	SEWING CLAMP LOWER (TRIANGLE-2)	
12-3-2	S19563	1	オサエヒタ"リ-3カク2	SEWING CLAMP LEFT (TRIANGLE-2)	
12-3-3	S19564	1	オサエミキ"-3カク2	SEWING CLAMP RIGHT (TRIANGLE-2)	
12-3-4	062400616	4	ナヘ"コM4X6	SCREW M4X6	
12-3-5	028040243	4	ハ"ネサ"カ"ネ2-4	SPRING WASHER 2 4	
12-3-6	S19069001	1	スヘ"ーサB	SPACER (B)	
12-3-7	S19070000	2	スヘ"ーサA	SPACER (A)	
12-3-8	062401016	3	ナヘ"コ4X10	SCREW 4X10	
12-3-9	062400616	4	ナヘ"コM4X6	SCREW M4X6	
12-3-10	028040243	7	ハ"ネサ"カ"ネ2-4	SPRING WASHER 2-4	
12-3-11	S12102000	2	ツインロツト"シリンタ"クミA	TWIN ROD CYLINDER ASSEMBLY (A)	
12-3-11-1	S12103000	2	ツインロツト"シリンタ"	TWIN ROD CYLINDER	
12-3-11-2	S11433000	4	ホ-スニツフ"ル4M5	HOSE NIPPLE 4M5	
12-3-12	S19071000	2	ツインロツト"シリンタ"クミB	TWIN ROD CYLINDER ASSEMBLY (B)	
12-3-12-1	S12103000	2	ツインロツト"シリンタ"	TWIN ROD CYLINDER	
12-3-12-2	S12150000	4	ホ-スエルホ"M-5HL-4	TUBE ELBOW (M-5HL-4)	
12-3-13	S19072001	2	イチキ"メミキ"	POSITIONING (RIGHT)	
12-3-14	S19073001	2	イチキ"メヒタ"リ	POSITIONING (LEFT)	
12-3-15	007402512	8	ヒラネシ"4X25	SCREW 4X25	
12-3-16	028040243	8	ハ"ネサ"カ"ネ2-4	SPRING WASHER 2-4	
12-3-17	S19074001	2	シリンタ"-ササエミキ"	CYLINDER SUPPORT (RIGHT)	
12-3-18	S19075001	2	シリンタ"-ササエヒタ"リ	CYLINDER SUPPORT (LEFT)	
12-3-19	062401012	8	ナヘ"コM4X10	SCREW M4X10	
12-3-20	028040242	8	ハ"ネサ"カ"ネ2-4	SPRING WASHER 2-4	
12-3-21	S19076000	3	ウスカ"タシリンタ"クミA	THIN TYPE CYLINDER ASSEMBLY (A)	
12-3-21-1	S19078000	3	ウスカ"タシリンタ"12-5	THIN TYPE CYLINDER 12-5	
12-3-21-2	S12150000	6	ホ-スエルホ"M-5HL-4	TUBE ELBOW (M-5HL-4)	
12-3-22	S19077000	1	ウスカ"タシリンタ"クミB	THIN TYPE CYLINDER ASSEMBLY (B)	
12-3-22-1	S19078000	1	ウスカ"タシリンタ"12-5	THIN TYPE CYLINDER 12-5	
12-3-22-2	S11433000	2	ホ-スニツフ"ル4M5	HOSE NIPPLE 4M5	
12-3-23	S12053000	8	CQ2ホ"ルトM3X25	CQ2 BOLT M3X25	
12-3-24	028030243	8	ハ"ネサ"カ"ネ2-3	SPRING WASHER 2-3	
12-3-25	018502022	8	アナホ"ルト5X20	BOLT 5X20	
12-3-26	021500303	8	ナツト3シユ5	NUT 5	
12-3-27	S19540001	2	ト"ク"ミキ"	DOG (RIGHT)	
12-3-28	S19541001	2	ト"ク"ヒタ"リ	DOG (LEFT)	
12-3-29	062400806	8	ナヘ"コ4X8	SCREW 4X8	
12-3-30	025040233	8	ヒラサ"カ"ネチユウ4	PLAIN WASHER 4	
12-3-31	028040243	8	ハ"ネサ"カ"ネ2-4	SPRING WASHER 2-4	
12-3-32	S19512000	1	2レツセンサクミ	DOUBLE SENSOR ASSEMBLY	
12-3-33	S19565000	1	ガ"イト"イター-3カク2	GUIDE PLATE (TRIANGLE-2)	
12-3-34	S19542001	4	タ"ンカラ-	STAGE COLLAR	
12-3-35	S19543001	4	サ"カ"ネ	WASHER	
12-3-36	062400806	4	ナヘ"コ4X8	SCREW 4X8	
12-3-37	028040243	4	ハ"ネサ"カ"ネ2-4	SPRING WASHER 2-4	
12-3-38	S19544001	2	スヘ"ーサー	SPACER	
12-3-39	S19076000	1	ウスカ"タシリンタ"クミA	THIN TYPE CYLINDER ASSEMBLY (A)	
12-3-39-1	S19078000	1	ウスカ"タシリンタ"12-5	THIN TYPE CYLINDER 12-5	
12-3-39-2	S12150000	2	ホ-スエルホ"M-5HL-4	TUBE ELBOW (M-5HL-4)	
12-3-40	S19545002	2	CQ2ホ"ルトM3X35	CQ2 BOLT M3X35	
12-3-41	028030243	2	ハ"ネサ"カ"ネ2-3	SPRING WASHER 2-3	
12-3-42	062400806	1	ナヘ"コM4X8	SCREW M4X8	
12-3-43	028040243	1	ハ"ネサ"カ"ネ2-4	SPRING WASHER 2-4	
12-3-44	S19546001	1	シリンタ"-ササエ	CYLINDER SUPPORT	
12-3-45	062400806	2	ナヘ"コ4X8	SCREW 4X8	
12-3-46	028040243	2	ハ"ネサ"カ"ネ2-4	SPRING WASHER 2-4	
12-3-47	025040233	2	ヒラサ"カ"ネチユウ4	PLAIN WASHER 4	
12-3-48	S19547000	1	ツインシリンタ"クミ15	TWIN CYLINDER ASSEMBLY 15	
12-3-48-1	S19548000	1	ツインシリンタ"クミ12-15	TWIN CYLINDER 2-15	
12-3-48-2	S12150000	2	ホ-スエルホ"M-5HL-4	TUBE ELBOW (M-5HL-4)	
12-3-49	062402016	2	ナヘ"コM4X20	SCREW M4X20	

S. 折曲メ関係 (特別注文部品)/Folding margin mechanism (Option parts)/Faltungsvorrichtung (Sonderzubehör)/
 Mécanisme de marge d'ourlet (Pièces en option)/Mecanismo de margen de plegado (Piezas a opción)

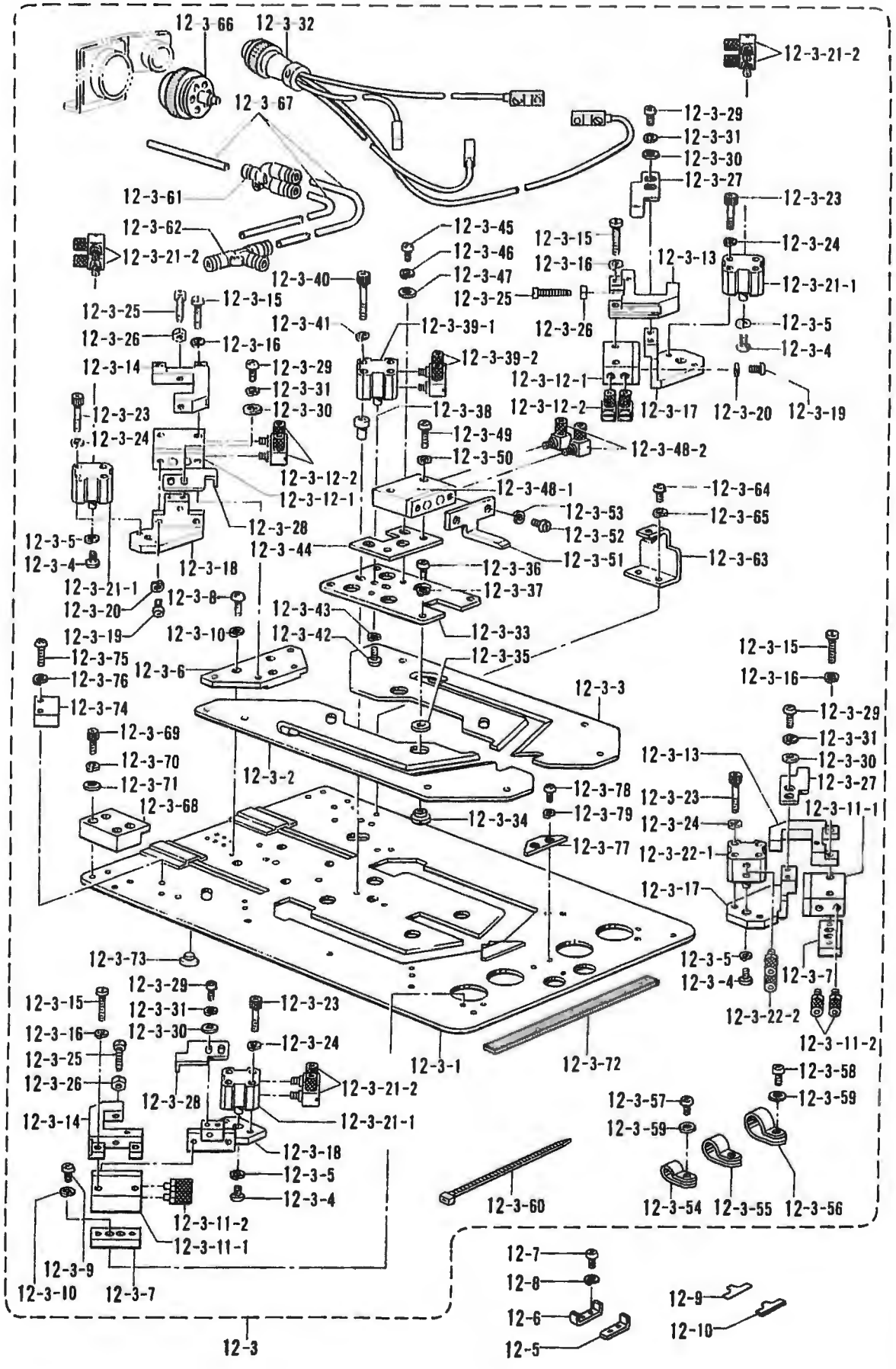

S. 折曲ゲ関係 (特別注文部品)/Folding margin mechanism (Option parts)/Faltungsvorrichtung (Sonderzubehör)/
Mécánisme de marge d'ourlet (Pièces en option)/Mecanismo de margen de plegado (Piezas a opción)

REL NO	CODE	Q'TY	品名	NAME OF PARTS	RMKS
12 3 50	028040243	2	ハ"ネサ"カ"ネ2-4	SPRING WASHER 2-4	
12 3 51	S19566	1	オサエナカ-3カク2	INNER CLAMP (TRIANGLE-2)	
12 3 52	062400806	2	ナヘ"コ4X8	SCREW 4X8	
12 3 53	028040243	2	ハ"ネサ"カ"ネ2-4	SPRING WASHER 2-4	
12 3 54	149547000	1	コート"オサエ 4N	CORD HOLDER 4N	
12 3 55	150826000	6	コート"オサエ 8N	CORD HOLDER 8N	
12 3 56	554482000	2	コート"ホルタ"12N	CORD HOLDER 12N	
12 3 57	062400616	7	ナヘ"コM4X6	SCREW M4X6	
12 3 58	062400806	2	ナヘ"コ4X8	SCREW 4X8	
12 3 59	025040233	9	ヒラサ"カ"ネチユウ4	PLAIN WASHER 4	
12 3 60	S04159000	2	バンド"1 M	BAND 1M	
12 3 61	S19557000	10	コカ"タユニオンワイ4	MINIATURE UNION-Y 4	
12 3 62	S19558000	4	コカ"タチ-ス"4	MINIATURE T-JOINT-4	
12 3 63	S19552001	1	チューブ"ササエA	TUBE SUPPORT (A)	
12-3 64	062400616	2	ナヘ"コM4X6	SCREW M4X6	
12-3 65	028040243	2	ハ"ネサ"カ"ネ2-4	SPRING WASHER 2-4	
12-3 66	S19549000	1	マルチコネクタ-6P	MULTI CONNECTOR (6P)	
12 3 67	S19551000	1	エア-ホ-ス4X2.5-W	AIR TUBE 4X2.5-W (L-6000)	
12-3 68	S12110001	2	コネクト"ブロック(オサエ)	CONNECT BLOCK (PRESSER)	
12-3 69	018401022	8	アナボ"ルト4X10	BOLT 4X10	
12 3-70	028040242	8	ハ"ネサ"カ"ネ2-4	SPRING WASHER 2-4	
12 3-71	025040232	8	ヒラサ"カ"ネチユウ4	PLAIN WASHER 4	
12-3-72	S12298000	2	フォーム3X15X1000	FORM 3X15X1000	
12-3 73	S12279000	6	ウケイタ(オサエ)	SUPPORT PLATE (PRESSER)	
12-3-74	S20890000	2	オサエ"ガイド"1	PRESSER GUIDE 1	
12-3-75	062401416	4	ナヘ"コ4X14	SCREW 4X14	
12-3 76	028040243	4	ハ"ネサ"カ"ネ2-4	SPRING WASHER 2-4	
12-3-77	S20891000	1	オサエ"ガイド"2	PRESSER GUIDE 2	
12-3-78	062400806	2	ナヘ"コ4X8	SCREW 4X8	
12-3-79	028040243	2	ハ"ネサ"カ"ネ2-4	SPRING WASHER 2-4	
12-5	S12111001	3	スリットC	SLIT (C)	
12-6	S12112001	3	スリットD	SLIT (D)	
12-7	062300502	6	ナヘ"コ3X5	SCREW 3X5	
12-8	028030242	6	ハ"ネサ"カ"ネ2-3	SPRING WASHER 2-3	
12-9	S16514000	2	スペ-サ0.05	SPACER 0.05	
12-10	S16513000	2	スペ-サ0.1	SPACER 0.1	

S. 折曲ゲ関係 (特別注文部品)/Folding margin mechanism (Option parts)/Faltungsvorrichtung (Sonderzubehör)/
 Mécanisme de marge d'ourlet (Pièces en option)/Mecanismo de margen de plegado (Piezas a opción)

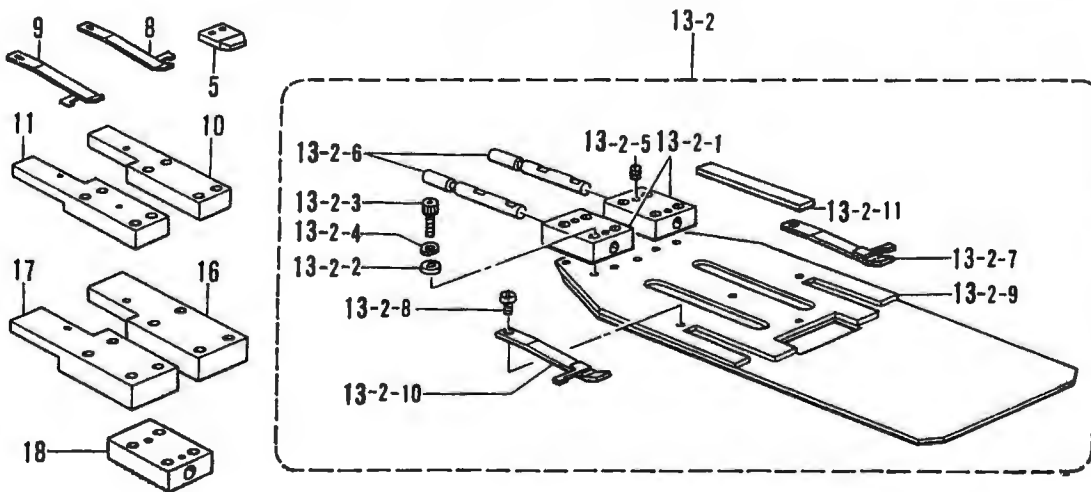
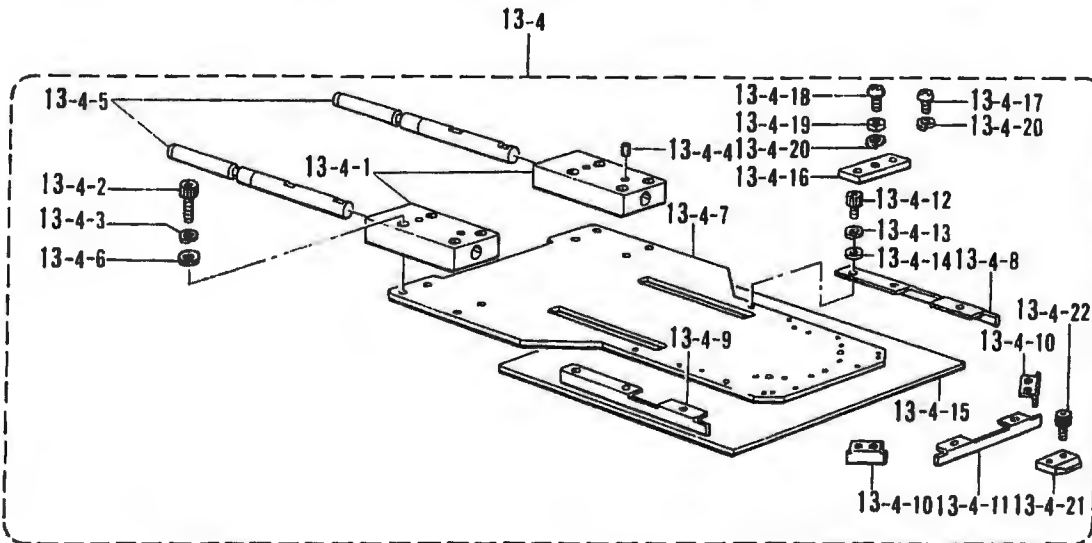
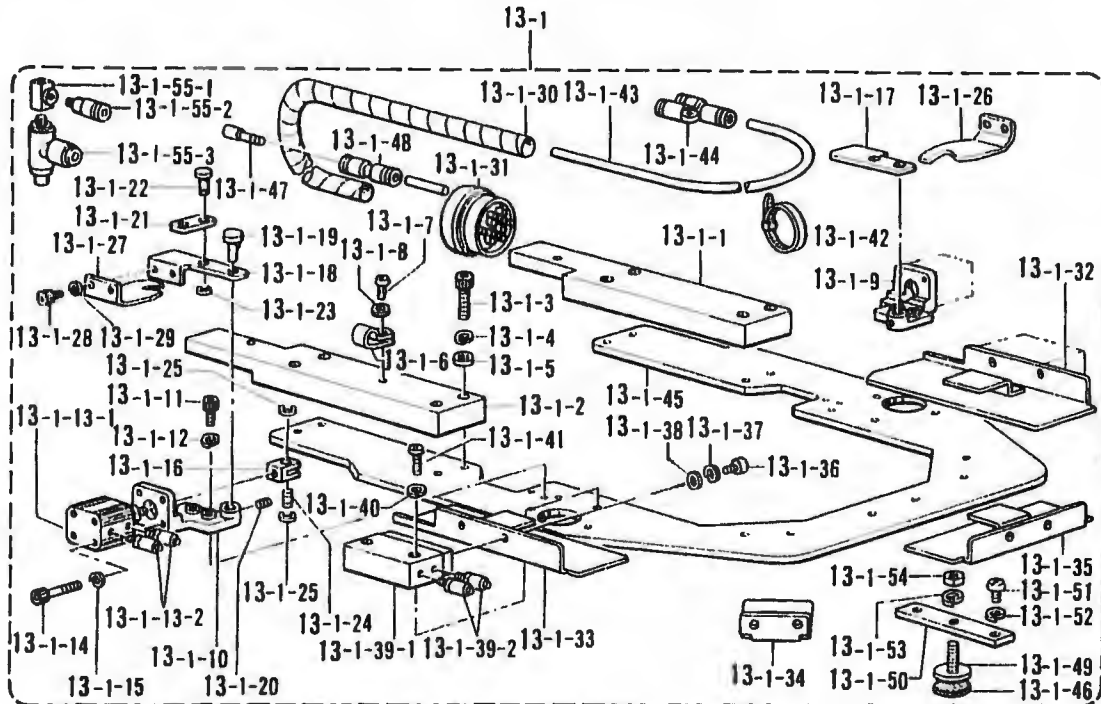

S. 折曲ゲ関係 (特別注文部品)/Folding margin mechanism (Option parts)/Faltungsvorrichtung (Sonderzubehör)/
 Mécanisme de marge d'ourlet (Pièces en option)/Mecanismo de margen de plegado (Piezas a opción)

RFI NO	CODEL	Q'TY	ヒンメイ	NAME OF PARTS	RMKS
13	S19567	1	オリキクミ-5カク2	FOLDING GROUP ASSEMBLY (MITER-2)	
13 1	S12306	1	オリササエクミ-5カク	FOLDING CLAMP ASSEMBLY (MITER)	
13 1 1	S12086001	1	コネクタブ"ロックR	CONNECT BLOCK (R)	
13 1 2	S12087001	1	コネクタブ"ロックL	CONNECT BLOCK (L)	
13 1 3	018502522	8	アナホ"ルト5X25	BOLT 5X25	
13 1 4	028050247	8	ハ"ネサ"カ"ネ2-5	SPRING WASHER 2 5	
13 1 5	025050232	8	ヒラサ"カ"ネチユウ-5	PLAIN WASHER 5	
13 1 6	525907000	1	コード"ホルタ"9N	CORD HOLDER 9N	
13 1 7	062401006	1	ナヘ"コ4X10	SCREW 4X10	
13 1 8	025040233	1	ヒラサ"カ"ネチユウ4	PLAIN WASHER 4	
13 1 9	S12088009	1	レハ"ー"ヘ"ースR	LEVER BASE (R)	
13 1 10	S12089009	1	レハ"ー"ヘ"ースL	LEVER BASE (L)	
13 1 11	018401222	4	アナホ"ルト4X12	BOLT 4X12	
13 1 12	028040242	4	ハ"ネサ"カ"ネ2-4	SPRING WASHER 2-4	
13 1 13	S12090000	2	シリンタ"ー12X10クミ	CYLINDER 12X10 ASSEMBLY	
13 1 13-1	S12091000	2	シリンタ"ー12X10	CYLINDER 12X10	
13 1 13 2	S11433000	4	ホースニツプル4M5	HOSE NIPPLE 4M5	
13 1 14	S12092000	8	CQ2ホ"ルトM3X30	CQ2 BOLT M3X30	
13 1 15	028030243	8	ハ"ネサ"カ"ネ2-3	SPRING WASHER 2-3	
13-1-16	S12093001	2	ナツクル	KNUCKLE	
13 1 17	S12094001	1	ヒンシ"R	HINGE (R)	
13-1-18	S12095001	1	ヒンシ"L	HINGE (L)	
13-1 19	S12096001	2	ヒンシ"ピン	PIN	
13-1-20	014400522	2	アナクホ"ミ4X5	SET SCREW 4X5	
13-1-21	S12097001	2	タイフ"レート	TIE PLATE	
13-1-22	S12098001	2	ピン	PIN	
13-1-23	048050342	2	トメワE5	STOP RING E5	
13-1-24	S12099001	2	ナツクルピン	PIN	
13-1-25	048050342	4	トメワE5	STOP RING E5	
13-1-26	S12475100	1	メントリイタR"タイ	TUCKING BLADE (R) LARGE	
13-1-27	S12476100	1	メントリイタL"タイ	TUCKING BLADE (L) LARGE	
13-1-28	018400632	4	アナホ"ルト4X6	BOLT 4X6	
13-1-29	028040242	4	ハ"ネサ"カ"ネ2-4	SPRING WASHER 2-4	
13-1-30	S12214000	1	スパイラル640L	SPIRAL 640L	
13-1-31	S12106000	1	マルチコネクタP	MULTI CONNECTOR (P)	
13-1-32	S12307---	1	オリイタR-5カク	TUCKING BLADE (R) (MITER)	
13-1-33	S12308---	1	オリイタL-5カク	TUCKING BLADE (L) (MITER)	
13-1-34	S12309---	2	オリイタS-5カク	TUCKING BLADE (S) (MITER)	
13-1-35	S12310---	1	オリイタM-5カク	TUCKING BLADE (M) (MITER)	
13-1-36	018400632	10	アナホ"ルト4X6	BOLT 4X6	
13-1-37	028040242	10	ハ"ネサ"カ"ネ2-4	SPRING WASHER 2-4	
13-1-38	025040232	14	ヒラサ"カ"ネチユウ4	PLAIN WASHER 4	
13-1-39	S12102000	5	ツインロッド"シリンタ"ークミ	TWIN ROD CYLINDER ASSEMBLY	
13-1-39-1	S12103000	5	ツインロッド"シリンタ"ー	TWIN ROD CYLINDER	
13-1-39-2	S11433000	10	ホースニツプル4M5	HOSE NIPPLE 4M5	
13-1-40	028040243	10	ハ"ネサ"カ"ネ2-4	SPRING WASHER 2-4	
13-1-41	062402016	10	ナヘ"コM4X20	SCREW M4X20	
13-1-42	S04159000	2	バンド"1M	BAND 1M	
13-1-43	S12205000	1	エアホ"ース4X2.5-29	AIR TUBE 4X2.5-29 (L=7500)	
13-1-44	S12104000	8	ユニオンワイ4	UNION-Y 4	
13-1-45	S12311---	1	オリササエ-5カク	FOLDING CLAMP (MITER)	
13-1-46	S12297000	2	スポンジ"2-30	SPONGE 2-30	
13-1-47	S04897000	2	メクラセン	BLIND CAP	
13-1-48	S04587000	2	ストレートツキ"テ	STRAIGHT JOINT	
13-1-49	S12291001	2	アジ"ヤストネジ"	ADJUST SCREW	
13-1-50	S12294001	2	トリツケイタ(オリササエ)	FITTING PLATE (FOLDING CLAMP)	
13-1-51	062401006	4	ナヘ"コ4X10	SCREW 4X10	
13-1-52	028040243	4	ハ"ネサ"カ"ネ2-4	SPRING WASHER 2-4	
13-1-53	028060243	2	ハ"ネサ"カ"ネ2-6	SPRING WASHER 2-6	
13-1-54	021060206	2	ナツト2シユ6	NUT 6	

S. 折曲ケ関係 (特別注文部品)/Folding margin mechanism (Option parts)/Faltungsvorrichtung (Sonderzubehör)/
 Mécanisme de marge d'ourlet (Pièces en option)/Mecanismo de margen de plegado (Piezas a opción)

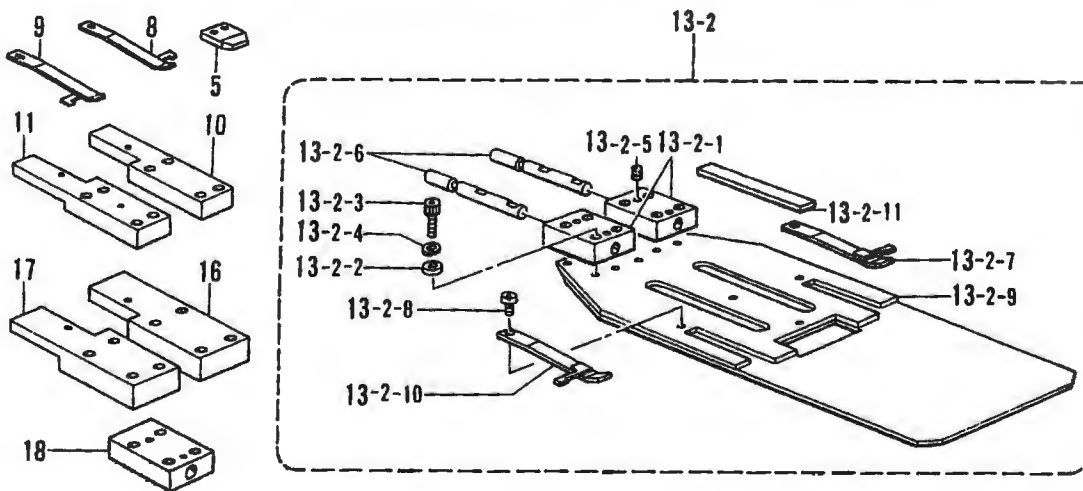
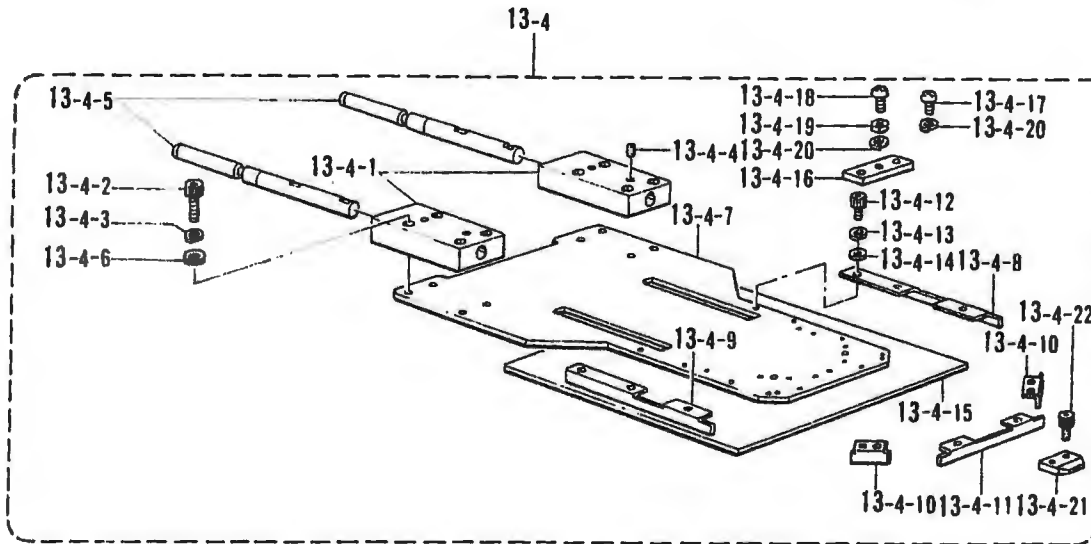
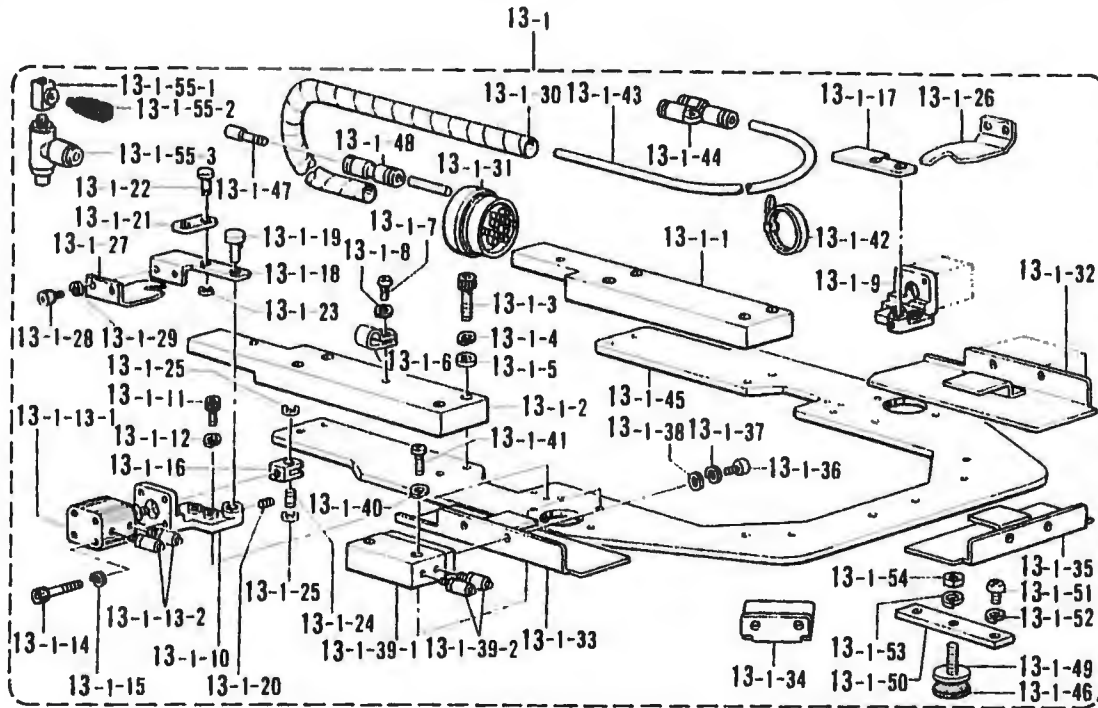

S. 折曲ゲ関係 (特別注文部品)/Folding margin mechanism (Option parts)/Faltungsvorrichtung (Sonderzubehör)/
 Mécanisme de marge d'ourlet (Pièces en option)/Mecanismo de margen de plegado (Piezas a opción)

REI NO	CODE	Q'TY	ヒンメイ	NAME OF PARTS	RMKS
13 1 55	S15564000	1	チ-M5クミ	T-M5 ASSEMBLY	
13 1 55 1	S15563000	1	チ-M5	T M5	
13 1 55 2	S04905000	1	ハーフユニオン	HALF UNION	
13 1 55 3	S14328000	2	ンボ"リハ"ン	THROTTLE VALVE	
13 2	S12312000	1	ケ"ー"ジ"クミ-5カク	CENTER BLADE ASSEMBLY (MITER)	
13 2 1	S12107001	2	コネクトフ"ロツク(ケ"ー"ジ")	CONNECT BLOCK (CENTER BLADE) (GAGE)	
13 2 2	025040232	8	ヒラサ"カ"ネチユウ4	PLAIN WASHER 4	
13 2 3	018402032	8	アナホ"ルト4X20	BOLT 4X20	
13 2 4	028040242	8	ハ"ネサ"カ"ネ2-4	SPRING WASHER 2 4	
13 2 5	014500522	4	アナトメネジ"5クホ"ミ	SET SCREW 5	
13 2 6	S12108001	2	コネクトピン(ケ"ー"ジ")	PIN (CENTER BLADE) (GAGE)	
13 2 7	S12109000	1	イタハ"ネR	PLATE SPRING (R)	
13 2 8	060300414	2	ハ"イント"3X4	SCREW 3X4	
13 2 9	S12313	1	ケ"ー"ジ"-5カク	CENTER BLADE (MITER)	
13 2 10	S12105000	1	イタハ"ネL	PLATE SPRING (L)	
13 2 11	S12278000	2	ウケイタ(ケ"ー"ジ")	SUPPORT PLATE (CENTER BLADE) (GAGE)	
13-4	S12316	1	ナカオサエクミ-5カク	INNER CLAMP ASSEMBLY (MITER)	
13 4 1	S12113001	2	コネクトフ"ロツク(ナカ)	CONNECT BLOCK (INNER)	
13 4 2	018502522	8	アナホ"ルト5X25	BOLT 5X25	
13 4 3	028050242	8	ハ"ネサ"カ"ネ2-5	SPRING WASHER 2-5	
13 4 4	014500522	4	アナトメネジ"5クホ"ミ	SET SCREW 5	
13 4 5	S12114001	2	コネクトピン(ナカ)	PIN (INNER)	
13-4-6	025050232	8	ヒラサ"カ"ネチユウ-5	PLAIN WASHER 5	
13-4-7	S12317---	1	ナカオサエ-5カク	INNER CLAMP (MITER)	
13-4-8	S12318---	1	ナカオサエウエ1-5カク	INNER CLAMP BLADE 1 (MITER)	
13 4 9	S12319	1	ナカオサエウエ2-5カク	INNER CLAMP BLADE 2 (MITER)	
13-4 10	S12320--	2	ナカオサエウエ3-5カク	INNER CLAMP BLADE 3 (MITER)	
13-4-11	S12321--	1	ナカオサエウエ4-5カク	INNER CLAMP BLADE 4 (MITER)	
13-4-12	018300532	10	アナホルト3X5	BOLT 3X5	
13-4-13	028030242	10	ハ"ネサ"カ"ネ2-3	SPRING WASHER 2-3	
13-4-14	025030232	10	ヒラサ"カ"ネチユウ3	PLAIN WASHER 3	
13-4-15	S12117000	1	フォーム2X200X200	FORM 2X200X200	
13-4-16	S12485001	2	トリツクイタ(ナカオサエ)	FITTING PLATE (INNER CLAMP)	
13-4-17	062400806	4	ナヘ"コ4X8	SCREW 4X8	
13-4-18	062401416	2	ナヘ"コ4X14	SCREW 4X14	
13-4-19	021400103	2	ナツト1シユ4	NUT 4	
13-4-20	028040243	6	ハ"ネサ"カ"ネ2-4	SPRING WASHER 2-4	
13-4-21	S12487000	3	オリイタウケ(ナカオサエ)	FOLDING PLATE SUPPORT (INNER CLAMP)	
13-4-22	018300532	6	アナホ"ルト3X5	BOLT 3X5	
5	S12494000	1	オリイタウケシヨウ	FOLDING PLATE SUPPORT (SMALL)	
8	S15565000	1	イタハ"ネR0.8	PLATE SPRING (R) 0.8	
9	S15566000	1	イタハ"ネL0.8	PLATE SPRING (L) 0.8	
10	S12507001	1	コネクトフ"ロツクSR	CONNECT BLOCK (SR)	
11	S12508001	1	コネクトフ"ロツクSL	CONNECT BLOCK (SL)	
16	S21121001	1	コネクトフ"ロツクSSR	CONNECT BLOCK (SSR)	
17	S21122001	1	コネクトフ"ロツクSSL	CONNECT BLOCK (SSL)	
18	S21123001	2	コネクトフ"ロツクS	CONNECT BLOCK (S)	

S. 折曲ゲ関係 (特別注文部品)/Folding margin mechanism (Option parts)/Faltungsvorrichtung (Sonderzubehör)/
 Mécanisme de marge d'ourlet (Pièces en option)/Mecanismo de margen de plegado (Piezas a opción)

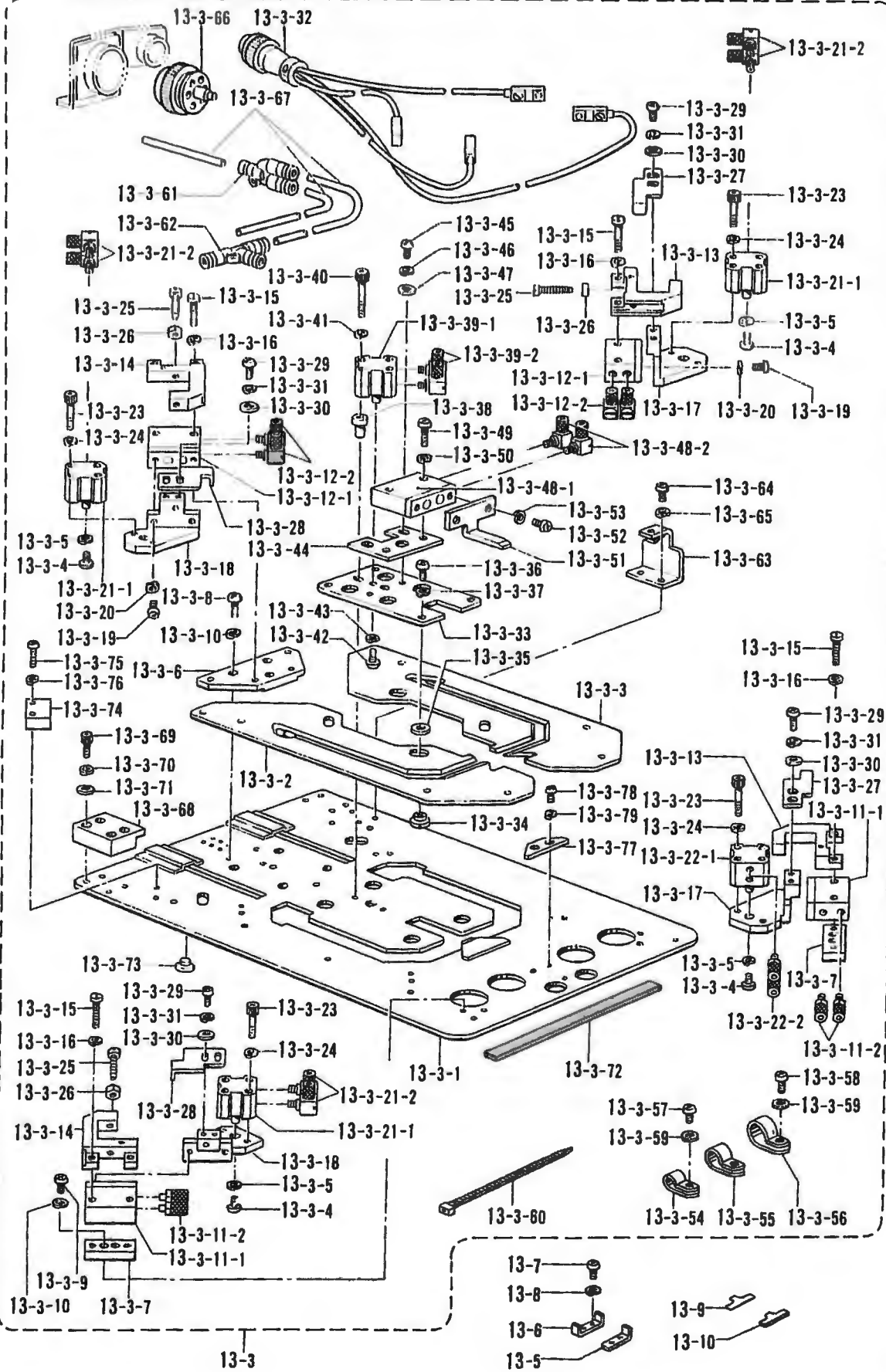

S. 折曲ゲ関係 (特別注文部品)/Folding margin mechanism (Option parts)/Faltungsvorrichtung (Sonderzubehör)/
 Mécanisme de marge d'ourlet (Pièces en option)/Mecanismo de margen de plegado (Piezas a opción)

RLI NO	CODE	Q'TY	ヒンメイ	NAME OF PARTS	RMKS
13 3	S19670	1	オサエクミ-5カク2	SEWING CLAMP ASSEMBLY (MITER 2)	
13 3 1	S19568	1	オサエシタ-5カク2	SEWING CLAMP LOWER (MITER 2)	
13 3 2	S19569	1	オサエヒタ"リ-5カク2	SEWING CLAMP LEFT (MITER-2)	
13 3 3	S19570	1	オサエミキ"-5カク2	SEWING CLAMP RIGHT (MITER 2)	
13 3 4	062400616	4	ナヘ"コM4X6	SCREW M4X6	
13 3 5	028040243	4	ハ"ネサ"カ"ネ2-4	SPRING WASHER 2 4	
13 3 6	S19069001	1	スヘ-サB	SPACER (B)	
13 3 7	S19070000	2	スヘ-サA	SPACER (A)	
13 3 8	062401016	3	ナヘ"コ4X10	SCREW 4X10	
13 3 9	062400616	4	ナヘ"コM4X6	SCREW M4X6	
13-3 10	028040243	7	ハ"ネサ"カ"ネ2-4	SPRING WASHER 2-4	
13 3 11	S12102000	2	ツインロッド"シリンダ"クミA	TWIN ROD CYLINDER ASSEMBLY (A)	
13 3 11 1	S12103000	2	ツインロッド"シリンダ"	TWIN ROD CYLINDER	
13 3 11 2	S11433000	4	ホースニツプル4M5	HOSE NIPPLE 4M5	
13-3 12	S19071000	2	ツインロッド"シリンダ"クミB	TWIN ROD CYLINDER ASSEMBLY (B)	
13 3 12 1	S12103000	2	ツインロッド"シリンダ"	TWIN ROD CYLINDER	
13 3 12 2	S12150000	4	ホースエルボ"M-5HL-4	TUBE ELBOW (M-5HL-4)	
13 3 13	S19072001	2	イチキ"メミキ"	POSITIONING (RIGHT)	
13-3-14	S19073001	2	イチキ"メヒタ"リ	POSITIONING (LEFT)	
13-3-15	007402512	8	ヒラネジ"4X25	SCREW 4X25	
13-3-16	028040243	8	ハ"ネサ"カ"ネ2-4	SPRING WASHER 2-4	
13-3-17	S19074001	2	シリンダ"-ササエミキ"	CYLINDER SUPPORT (RIGHT)	
13-3-18	S19075001	2	シリンダ"-ササエヒタ"リ	CYLINDER SUPPORT (LEFT)	
13-3-19	062401012	8	ナヘ"コM4X10	SCREW M4X10	
13-3-20	028040242	8	ハ"ネサ"カ"ネ2-4	SPRING WASHER 2-4	
13-3-21	S19076000	3	ウスカ"タシリンダ"クミA	THIN TYPE CYLINDER ASSEMBLY (A)	
13-3-21-1	S19078000	3	ウスカ"タシリンダ"12-5	THIN TYPE CYLINDER 12-5	
13-3-21-2	S12150000	6	ホースエルボ"M-5HL-4	TUBE ELBOW (M-5HL-4)	
13-3-22	S19077000	1	ウスカ"タシリンダ"クミB	THIN TYPE CYLINDER ASSEMBLY (B)	
13-3-22-1	S19078000	1	ウスカ"タシリンダ"12-5	THIN TYPE CYLINDER 12-5	
13-3-22-2	S11433000	2	ホースニツプル4M5	HOSE NIPPLE 4M5	
13-3-23	S12053000	8	CQ2ボルトM3X25	CQ2 BOLT M3X25	
13-3-24	028030243	8	ハ"ネサ"カ"ネ2-3	SPRING WASHER 2-3	
13-3-25	018502022	8	アナボ"ルト5X20	BOLT 5X20	
13-3-26	021500303	8	ナット3シユ5	NUT 5	
13-3-27	S19540001	2	ト"ク"ミキ"	DOG (RIGHT)	
13-3-28	S19541001	2	ト"ク"ヒタ"リ	DOG (LEFT)	
13-3-29	062400806	8	ナヘ"コ4X8	SCREW 4X8	
13-3-30	025040233	8	ヒラサ"カ"ネチユウ4	PLAIN WASHER 4	
13-3-31	028040243	8	ハ"ネサ"カ"ネ2-4	SPRING WASHER 2-4	
13-3-32	S19512000	1	2レツセンサクミ	DOUBLE ROW SENSOR ASSEMBLY	
13-3-33	S19571---	1	ガイド"イター-5カク2	GUIDE PLATE (MITER-2)	
13-3-34	S19542001	4	タ"ンカラ-	STAGE COLLAR	
13-3-35	S19543001	4	サ"カ"ネ	WASHER	
13-3-36	062400806	4	ナヘ"コ4X8	SCREW 4X8	
13-3-37	028040243	4	ハ"ネサ"カ"ネ2-4	SPRING WASHER 2-4	
13-3-38	S19544001	2	スヘ-サー	SPACER	
13-3-39	S19076000	1	ウスカ"タシリンダ"クミA	THIN TYPE CYLINDER ASSEMBLY (A)	
13-3-39-1	S19078000	1	ウスカ"タシリンダ"12-5	THIN TYPE CYLINDER 12-5	
13-3-39-2	S12150000	2	ホースエルボ"M-5HL-4	TUBE ELBOW (M-5HL-4)	
13-3-40	S19545002	2	CQ2ボルトM3X35	CQ2 BOLT M3X35	
13-3-41	028030243	2	ハ"ネサ"カ"ネ2-3	SPRING WASHER 2-3	
13-3-42	062400806	1	ナヘ"コM4X8	SCREW M4X8	
13-3-43	028040243	1	ハ"ネサ"カ"ネ2-4	SPRING WASHER 2-4	
13-3-44	S19546001	1	シリンダ"-ササエ	CYLINDER SUPPORT	
13-3-45	062400806	2	ナヘ"コ4X8	SCREW 4X8	
13-3-46	028040243	2	ハ"ネサ"カ"ネ2-4	SPRING WASHER 2-4	
13-3-47	025040233	5	ヒラサ"カ"ネチユウ4	PLAIN WASHER 4	
13-3-48	S19547000	1	ツインシリンダ"クミ15	TWIN CYLINDER ASSEMBLY 15	
13-3-48-1	S19548000	1	ツインシリンダ"クミ12-15	TWIN CYLINDER 12-15	
13-3-48-2	S12150000	2	ホースエルボ"M-5HL-4	TUBE ELBOW (M-5HL-4)	
13-3-49	062402016	2	ナヘ"コM4X20	SCREW M4X20	

S. 折曲ゲ関係 (特別注文部品)/Folding margin mechanism (Option parts)/Faltungsvorrichtung (Sonderzubehör)/
 Mécanisme de marge d'ourlet (Pièces en option)/Mecanismo de margen de plegado (Piezas a opción)

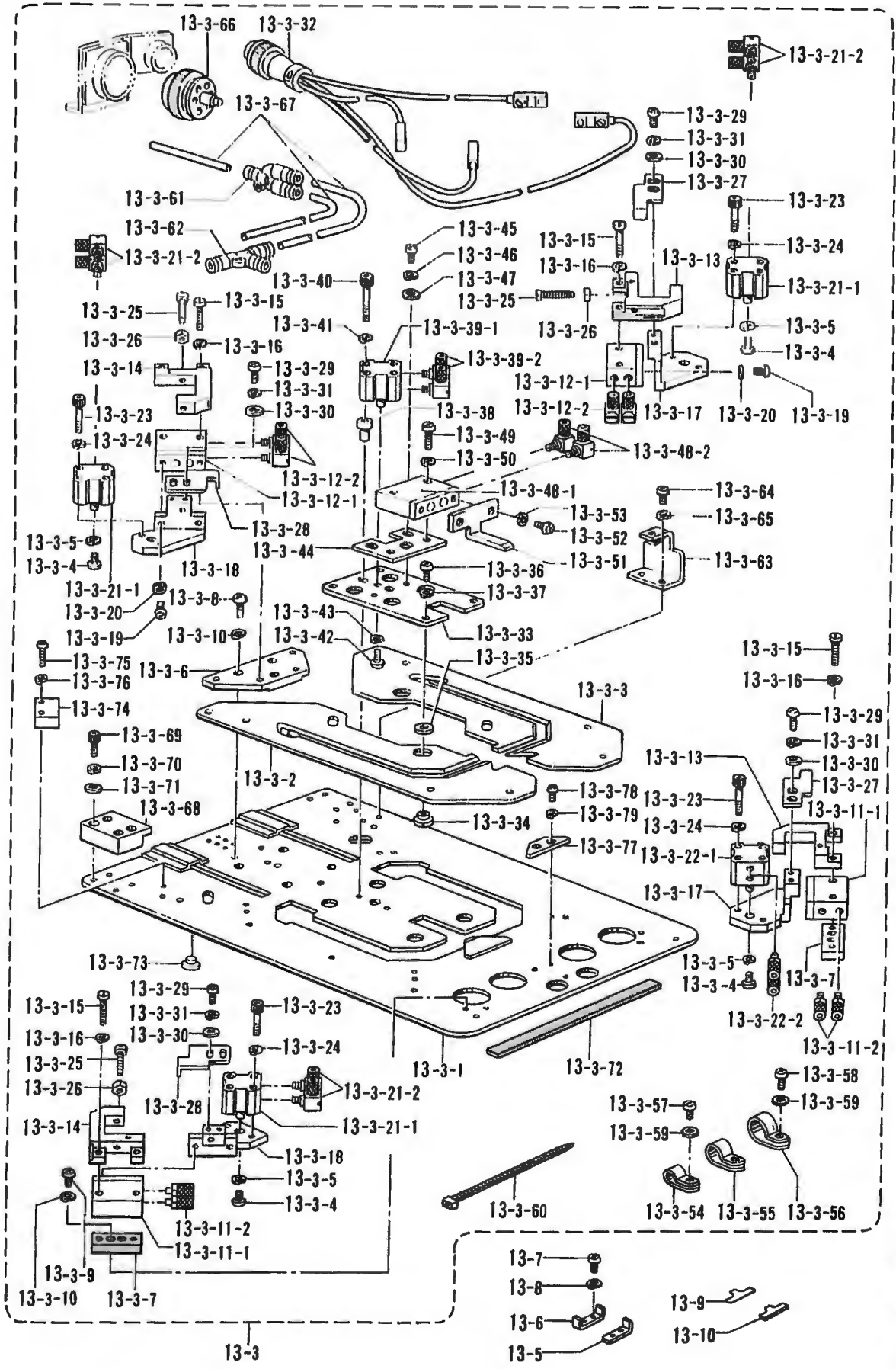

S. 折曲ゲ関係 (特別注文部品)/Folding margin mechanism (Option parts)/Faltungsvorrichtung (Sonderzubehör)/
 Mécanisme de marge d'ourlet (Pièces en option)/Mecanismo de margen de plegado (Piezas a opción)

REF NO	CODE	O'TY	品名	NAME OF PARTS	RMKS
13 3 50	028040243	2	ハ"ネサ"カ"ネ2-4	SPRING WASHER 2 4	
13 3 51	S19572	1	オサエナカ-5カク2	INNER CLAMP (MITER-2)	
13 3 52	062400806	2	ナヘ"コ4X8	SCREW 4X8	
13 3 53	028040243	2	ハ"ネサ"カ"ネ2-4	SPRING WASHER 2-4	
13-3 54	149547000	1	コート"オサエ 4N	CORD HOLDER 4N	
13 3 55	150826000	6	コート"オサエ 8N	CORD HOLDER 8N	
13-3 56	554482000	2	コート"ホルダ"12N	CORD HOLDER 12N	
13 3 57	062400616	7	ナヘ"コM4X6	SCREW M4X6	
13 3 58	062400806	2	ナヘ"コ4X8	SCREW 4X8	
13-3 59	025040233	9	ヒラサ"カ"ネチユウ4	PLAIN WASHER 4	
13-3 60	S04159000	2	バンド"1M	BAND 1M	
13-3 61	S19557000	10	コガ"タユニオンワイ4	MINIATURE UNION-Y 4	
13-3 62	S19558000	4	コガ"タチース"4	MINIATURE T-JOINT-4	
13 3 63	S19552001	1	チューブ"ササエA	TUBE SUPPORT (A)	
13-3 64	062400616	2	ナヘ"コM4X6	SCREW M4X6	
13 3 65	028040243	2	ハ"ネサ"カ"ネ2-4	SPRING WASHER 2-4	
13-3 66	S19549000	1	マルチコネクター-6P	MULTI CONNECTOR (6P)	
13 3 67	S19551000	1	エア-ホース4X2.5-W	AIR TUBE 4X2.5-W (L=6000)	
13 3 68	S12110001	2	コネクト"ブロック(オサエ)	CONNECT BLOCK (PRESSER)	
13-3 69	018401022	8	ボルト"4X10	BOLT 4X10	
13-3 70	028040242	8	ハ"ネサ"カ"ネ2-4	SPRING WASHER 2-4	
13-3-71	025040232	8	ヒラサ"カ"ネチユウ4	PLAIN WASHER 4	
13-3-72	S12298000	2	フォーム3X15X1000	FORM 3X15X1000	
13-3-73	S12279000	6	ウケイタ(オサエ)	SUPPORT PLATE (PRESSER)	
13-3-74	S20890000	2	オサエ"ガイド"1	PRESSER GUIDE 1	
13-3-75	062401416	4	ナヘ"コ4X14	SCREW 4X14	
13-3-76	028040243	4	ハ"ネサ"カ"ネ2-4	SPRING WASHER 2-4	
13-3-77	S20891000	1	オサエ"ガイド"2	PRESSER GUIDE 2	
13-3-78	062400806	2	ナヘ"コ4X8	SCREW 4X8	
13-3-79	028040243	2	ハ"ネサ"カ"ネ2-4	SPRING WASHER 2-4	
13-5	S12111001	3	スリットC	SLIT (C)	
13-6	S12112001	3	スリットD	SLIT (D)	
13-7	062300502	6	ナヘ"コ3X5	SCREW 3X5	
13-8	028030242	6	ハ"ネサ"カ"ネ2-3	SPRING WASHER 2-3	
13-9	S16514000	2	スペーサ0.05	SPACER 0.05	
13-10	S16513000	2	スペーサ0.1	SPACER 0.1	

S. 折曲関係 (特別注文部品)/Folding margin mechanism (Option parts)/Faltungsvorrichtung (Sonderzubehör)/
 Mécanisme de marge d'ourlet (Pièces en option)/Mecanismo de margen de plegado (Piezas a opción)

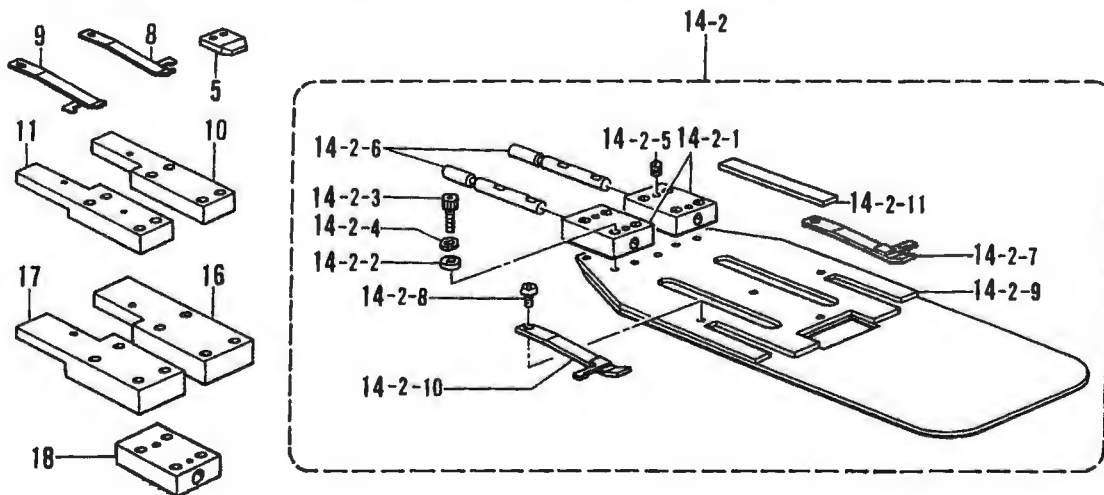
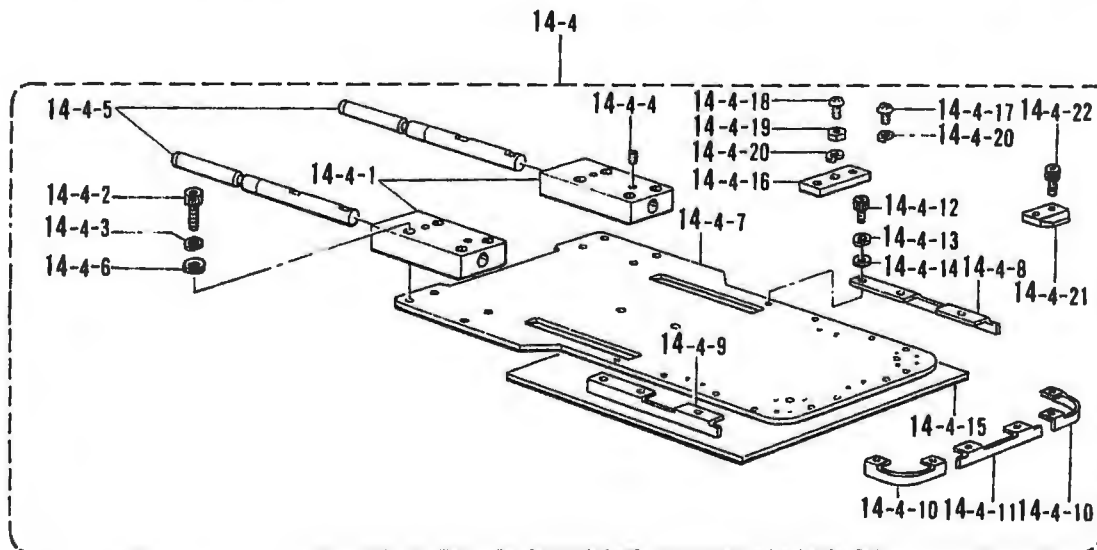
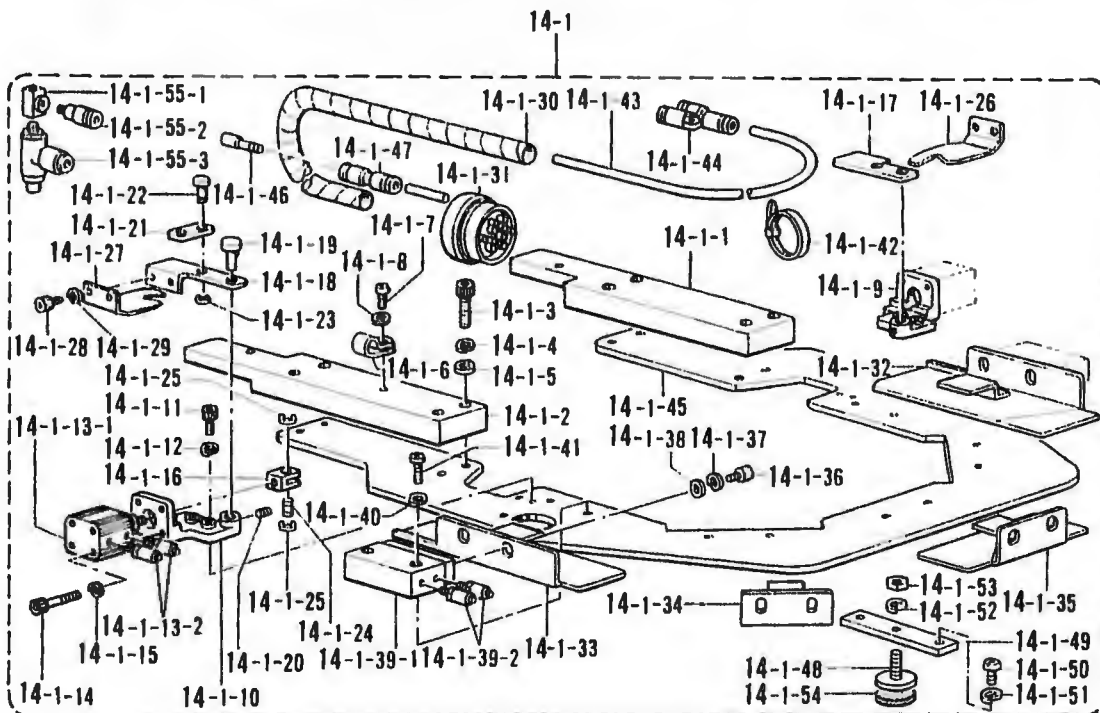

S. 折曲ゲ関係 (特別注文部品)/Folding margin mechanism (Option parts)/Faltungsvorrichtung (Sonderzubehör)/
Mécánisme de marge d'ourlet (Pièces en option)/Mecanismo de margen de plegado (Piezas a opción)

RLF NO	CODE	QTY	ヒンメイ	NAME OF PARTS	RMKS
14	S19573	1	オリキクミーマル2	FOLDING GROUP ASSEMBLY (ROUND-2)	
14 1	S12324	1	オリササエクミーマル	FOLDING CLAMP ASSEMBLY (ROUND)	
14 1 1	S12086001	1	コネクタブ"ロツクR	CONNECT BLOCK (R)	
14 1 2	S12087001	1	コネクタブ"ロツクL	CONNECT BLOCK (L)	
14 1 3	018502522	8	アナホ"ルト5X25	BOLT 5X25	
14 1 4	028050242	8	ハ"ネサ"カ"ネ2-5	SPRING WASHER 2 5	
14 1 5	025050232	8	ヒラサ"カ"ネチユウ-5	PLAIN WASHER 5	
14 1 6	525907000	1	コード"ホルタ"9N	CORD HOLDER 9N	
14 1 7	062401006	1	ナヘ"コ4X10	SCREW 4X10	
14 1 8	025040233	1	ヒラサ"カ"ネチユウ4	PLAIN WASHER 4	
14 1 9	S12088009	1	レハ"ーヘ"ースR	LEVER BASE (R)	
14 1 10	S12089009	1	レハ"ーヘ"ースL	LEVER BASE (L)	
14 1 11	018401222	4	アナホ"ルト4X12	BOLT 4X12	
14 1 12	028040242	4	ハ"ネサ"カ"ネ2-4	SPRING WASHER 2-4	
14 1 13	S12090000	2	ツリンタ"ー12X10クミ	CYLINDER 12X10 ASSEMBLY	
14 1 13 1	S12091000	2	ツリンタ"ー12X10	CYLINDER 12X10	
14 1 13 2	S11433000	4	ホースニツツ"ル4M5	HOSE NIPPLE 4M5	
14 1 14	S12092000	8	CQ2ホ"ルトM3X30	CQ2 BOLT M3X30	
14-1-15	028030243	8	ハ"ネサ"カ"ネ2-3	SPRING WASHER 2-3	
14-1-16	S12093001	2	ナツクル	KNUCKLE	
14-1-17	S12094001	1	ヒンシ"R	HINGE (R)	
14-1-18	S12095001	1	ヒンシ"L	HINGE (L)	
14-1-19	S12096001	2	ヒンシ"ピン	PIN	
14-1-20	014400522	2	アナクホ"ニ4X5	SET SCREW 4X5	
14-1-21	S12097001	2	タイフ"レート	TIE PLATE	
14-1-22	S12098001	2	ピン	PIN	
14-1-23	048050342	2	トメフE5	STOP RING E5	
14-1-24	S12099001	2	ナツクル"ピン	PIN	
14-1-25	048050342	4	トメフE5	STOP RING E5	
14-1-26	S12475100	1	メントリイタR"タイ	TUCKING BLADE (R) LARGE	
14-1-27	S12476100	1	メントリイタL"タイ	TUCKING BLADE (L) LARGE	
14-1-28	018400632	4	アナホ"ルト4X6	BOLT 4X6	
14-1-29	028040242	4	ハ"ネサ"カ"ネ2-4	SPRING WASHER 2-4	
14-1-30	S12214000	1	スパイラル640L	SPIRAL 640L	
14-1-31	S12106000	1	マルチコネクタP	MULTI CONNECTOR (P)	
14-1-32	S12325---	1	オリイタR-マル	TUCKING BLADE (R) (ROUND)	
14-1-33	S12326---	1	オリイタL-マル	TUCKING BLADE (L) (ROUND)	
14-1-34	S12327---	2	オリイタS-マル	TUCKING BLADE (S) (ROUND)	
14-1-35	S12328---	1	オリイタM-マル	TUCKING BLADE (M) (ROUND)	
14-1-36	018400632	10	アナホ"ルト4X6	BOLT 4X6	
14-1-37	028040242	10	ハ"ネサ"カ"ネ2-4	SPRING WASHER 2-4	
14-1-38	025040232	14	ヒラサ"カ"ネチユウ4	PLAIN WASHER 4	
14-1-39	S12102000	5	ツインロッド"ツリンタ"クミ	TWIN ROD CYLINDER ASSEMBLY	
14-1-39-1	S12103000	5	ツインロッド"ツリンタ"	TWIN ROD CYLINDER	
14-1-39-2	S11433000	10	ホースニツツ"ル4M5	HOSE NIPPLE 4M5	
14-1-40	028040243	10	ハ"ネサ"カ"ネ2-4	SPRING WASHER 2-4	
14-1-41	062402016	10	ナヘ"コM4X20	SCREW M4X20	
14-1-42	S04159000	2	バンド"1M	BAND 1M	
14-1-43	S12205000	1	エアホース4X2.5-29	AIR TUBE 4X2.5-29 (L=7500)	
14-1-44	S12104000	8	ユニオンワイ4	UNION-Y 4	
14-1-45	S12329---	1	オリササエ-マル	FOLDING CLAMP (ROUND)	
14-1-46	S04897000	2	メクラセン	BLIND CAP	
14-1-47	S04587000	2	ストレートツキ"テ	STRAIGHT JOINT	
14-1-48	S12291001	2	アジ"ヤストネシ"	ADJUST SCREW	
14-1-49	S12294001	2	トリツケイタ(オリササエ)	FITTING PLATE (FOLDING CLAMP)	
14-1-50	062401006	4	ナヘ"コ4X10	SCREW 4X10	
14-1-51	028040243	4	ハ"ネサ"カ"ネ2-4	SPRING WASHER 2-4	
14-1-52	028060243	2	ハ"ネサ"カ"ネ2-6	SPRING WASHER 2-6	
14-1-53	021060206	2	ナツト2"シユ6	NUT 6	
14-1-54	S12297000	2	スポンジ"2-30	SPONGE 2-30	

S. 折曲ゲ関係 (特別注文部品)/Folding margin mechanism (Option parts)/Faltungsvorrichtung (Sonderzubehör)/
 Mécanisme de marge d'ourlet (Pièces en option)/Mecanismo de margen de plegado (Piezas a opción)

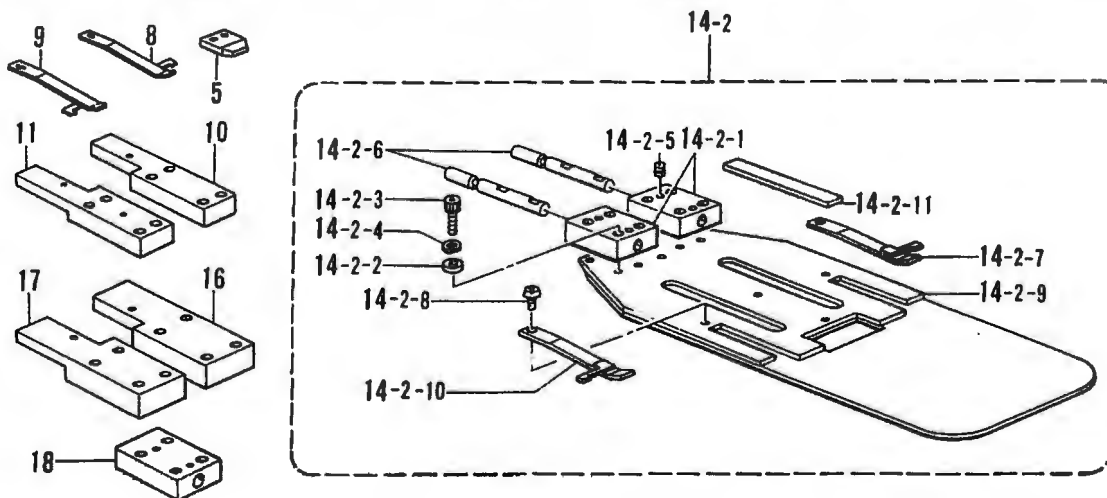
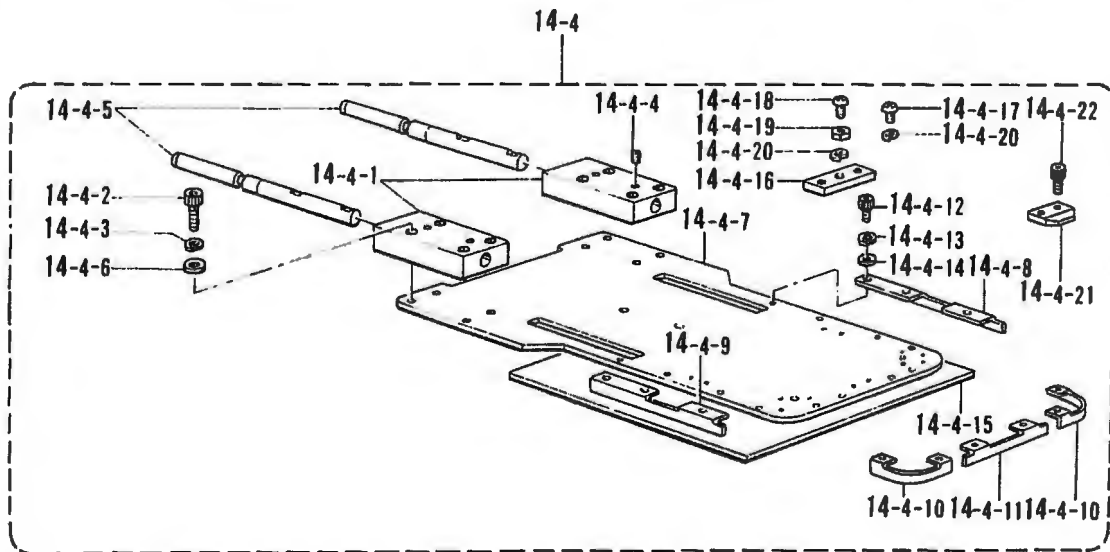
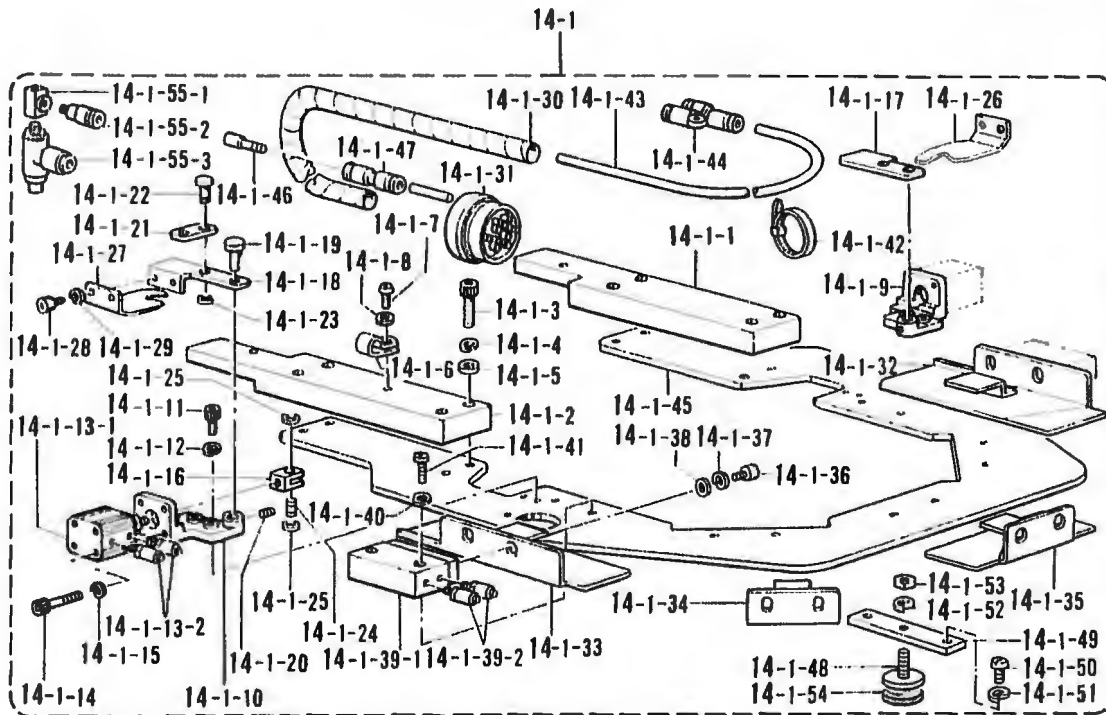

S. 折曲ケ関係 (特別注文部品)/Folding margin mechanism (Option parts)/Faltungsvorrichtung (Sonderzubehör)/
 Mécanisme de marge d'ourlet (Pièces en option)/Mecanismo de margen de plegado (Piezas a opción)

REF NO.	CODE	Q'TY	ヒンメイ	NAME OF PARTS	RMKS
14 1 55	S15564000	1	チ-M5クミ	T M5 ASSEMBLY	
14 1 55 1	S15563000	1	チ-M5	T-M5	
14 1-55-2	S04905000	1	ハーフユニオン	HALF UNION	
14 1 55 3	S14328000	2	シホ"リハ"ン	THROTTLE VALVE	
14 2	S12330	1	ケージクミーマル	CENTER BLADE ASSEMBLY (ROUND)	
14 2 1	S12107001	2	コネクタブ"ロツク(ケージ)	CONNECT BLOCK (CENTER BLADE) (GAGE)	
14 2 2	025040232	8	ヒラサ"カ"ネチユウ4	PLAIN WASHER 4	
14 2 3	018402032	8	アナホ"ルト4X20	BOLT 4X20	
14-2 4	028040242	8	ハ"ネサ"カ"ネ2-4	SPRING WASHER 2 4	
14 2 5	014500522	4	アナトメネシ"5クホ"ミ	SET SCREW 5	
14 2 6	S12108001	2	コネクトピン(ケージ)	PIN (CENTER BLADE) (GAGE)	
14 2 7	S12109000	1	イタハ"ネR	PLATE SPRING (R)	
14 2 8	060300414	2	ハ"イント"3X4	SCREW 3X4	
14 2 9	S12331---	1	ケージーマル	CENTER BLADE (ROUND)	
14 2 10	S12105000	1	イタハ"ネL	PLATE SPRING (L)	
14 2 11	S12278000	2	ウケイタ(ケージ)	SUPPORT PLATE (CENTER BLADE) (GAGE)	
14-4	S12334-	1	ナカオサエクミーマル	INNER CLAMP ASSEMBLY (ROUND)	
14-4 1	S12113001	2	コネクタブ"ロツク(ナカ)	CONNECT BLOCK (INNER)	
14-4-2	018502522	8	アナホ"ルト5X25	BOLT 5X25	
14-4-3	028050242	8	ハ"ネサ"カ"ネ2-5	SPRING WASHER 2-5	
14-4-4	014500522	4	アナトメネシ"5クホ"ミ	SET SCREW 5	
14-4-5	S12114001	2	コネクトピン(ナカ)	PIN (INNER)	
14-4-6	025050232	8	ヒラサ"カ"ネチユウ5	PLAIN WASHER 5	
14-4-7	S12335---	1	ナカオサエーマル	INNER CLAMP (ROUND)	
14-4-8	S12336---	1	ナカオサエウエ1-マル	INNER CLAMP UPPER 1 (ROUND)	
14-4-9	S12337---	1	ナカオサエウエ2-マル	INNER CLAMP UPPER 2 (ROUND)	
14-4-10	S12338---	2	ナカオサエウエ3-マル	INNER CLAMP UPPER 3 (ROUND)	
14-4-11	S12339---	1	ナカオサエウエ4-マル	INNER CLAMP UPPER 4 (ROUND)	
14-4-12	018300532	10	アナホ"ルト3X5	BOLT 3X5	
14-4-13	028030242	10	ハ"ネサ"カ"ネ2-3	SPRING WASHER 2-3	
14-4-14	025030232	10	ヒラサ"カ"ネチユウ3	PLAIN WASHER 3	
14-4-15	S12117000	1	フォーム2X200X200	FORM 2X200X200	
14-4-16	S12485001	2	トリツケイタ(ナカオサエ)	FITTING PLATE (INNER CLAMP)	
14-4-17	062400806	4	ナヘ"コ4X8	SCREW 4X8	
14-4-18	062401416	2	ナヘ"コ4X14	SCREW 4X14	
14-4-19	021400103	2	ナツト1シユ4	NUT 4	
14-4-20	028040243	6	ハ"ネサ"カ"ネ2-4	SPRING WASHER 2-4	
14-4-21	S12487000	5	オリイタウケ(ナカオサエ)	FOLDING PLATE SUPPORT (INNER CLAMP)	
14-4-22	018300532	10	アナホ"ルト3X5	BOLT 3X5	
5	S12494000	1	オリイタウケシヨウ	FOLDING PLATE SUPPORT (SMALL)	
8	S15565000	1	イタハ"ネR0.8	PLATE SPRING (R) 0.8	
9	S15566000	1	イタハ"ネL0.8	PLATE SPRING (L) 0.8	
10	S12507001	1	コネクタブ"ロツクSR	CONNECT BLOCK (SR)	
11	S12508001	1	コネクタブ"ロツクSL	CONNECT BLOCK (SL)	
16	S21121001	1	コネクタブ"ロツクSSR	CONNECT BLOCK (SSR)	
17	S21122001	1	コネクタブ"ロツクSSL	CONNECT BLOCK (SSL)	
18	S21123001	2	コネクタブ"ロツクS	CONNECT BLOCK (S)	

S. 折曲ゲ関係 (特別注文部品)/Folding margin mechanism (Option parts)/Faltungsvorrichtung (Sonderzubehör)/
Mécanisme de marge d'ourlet (Pièces en option)/Mecanismo de margen de plegado (Piezas a opción)

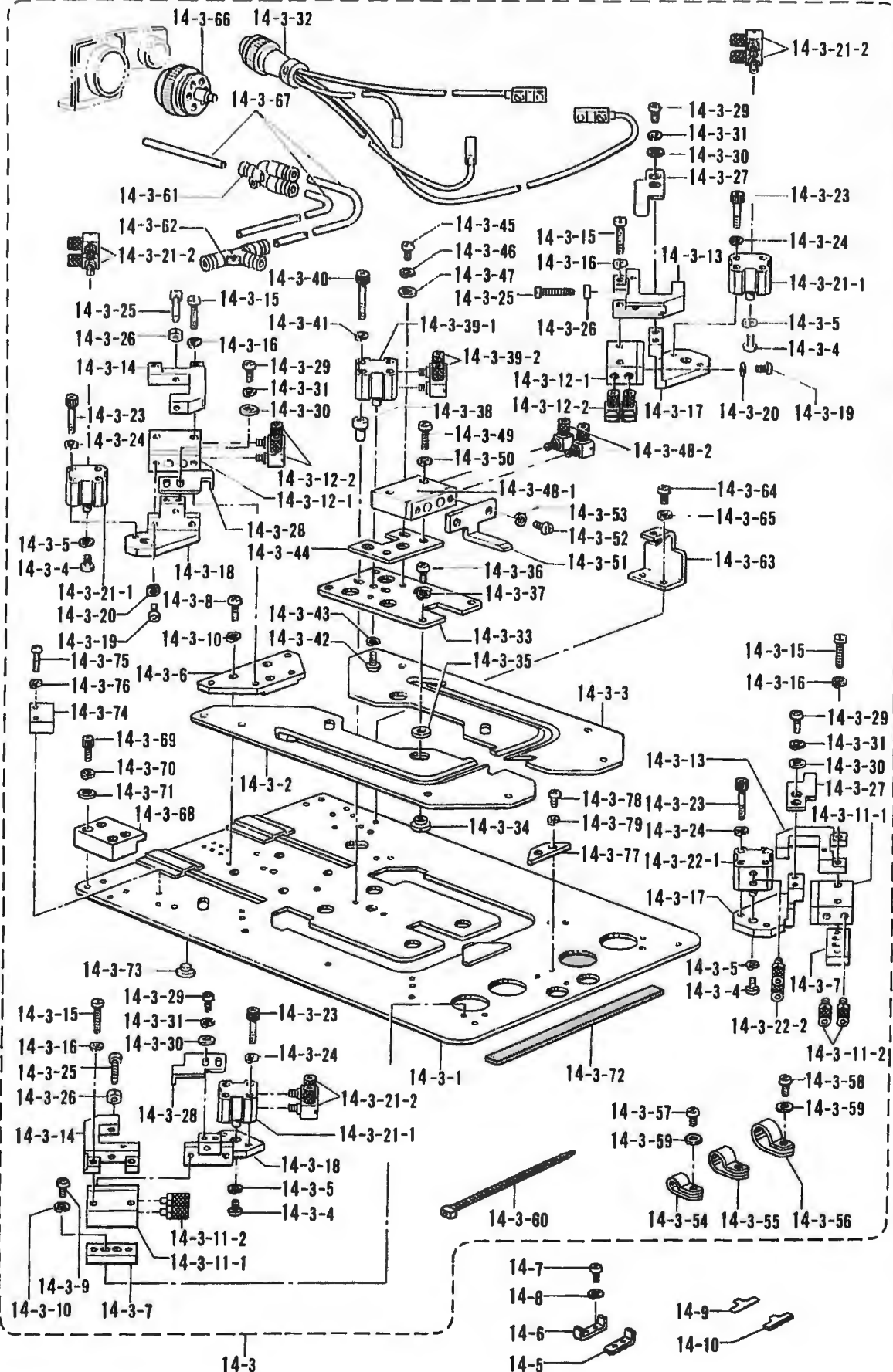

S. 折曲ゲ関係 (特別注文部品)/Folding margin mechanism (Option parts)/Faltungsvorrichtung (Sonderzubehör)/
 Mécanisme de marge d'ourlet (Pièces en option)/Mecanismo de margen de plegado (Piezas a opción)

RLF NO.	CODE	Q'TY	ヒンメイ	NAME OF PARTS	RMKS
14 3	S19671	1	オサエクミーマル2	SEWING CLAMP ASSEMBLY (ROUND-2)	
14 3 1	S19674	1	オサエシターマル2	SEWING CLAMP LOWER (ROUND-2)	
14-3-2	S19575	1	オサエヒタリーマル2	SEWING CLAMP LEFT (ROUND-2)	
14 3 3	S19676	1	オサエミキママル2	SEWING CLAMP RIGHT (ROUND-2)	
14 3 4	062400616	4	ナヘ"COM4X6	SCREW M4X6	
14 3 5	028040243	4	ハ"ネサ"ガ"ネ2-4	SPRING WASHER 2-4	
14 3 6	S19069001	1	スヘーサB	SPACER (B)	
14-3-7	S19070000	2	スヘーサA	SPACER (A)	
14 3 8	062401016	3	ナヘ"コ4X10	SCREW 4X10	
14 3 9	062400616	4	ナヘ"COM4X6	SCREW M4X6	
14-3-10	028040243	7	ハ"ネサ"ガ"ネ2-4	SPRING WASHER 2-4	
14 3 11	S12102000	2	ツインロツト"シリシタ"クミA	TWIN ROD CYLINDER ASSEMBLY (A)	
14 3 11 1	S12103000	2	ツインロツト"シリシタ"	TWIN ROD CYLINDER	
14 3 11 2	S11433000	4	ホースニツプル4M5	HOSE NIPPLE 4M5	
14-3-12	S19071000	2	ツインロツト"シリシタ"クミB	TWIN ROD CYLINDER ASSEMBLY (B)	
14 3 12 1	S12103000	2	ツインロツト"シリシタ"	TWIN ROD CYLINDER	
14 3 12 2	S12150000	4	ホースエルボ"M-5HL-4	TUBE ELBOW (M-5HL-4)	
14 3 13	S19072001	2	イチキ"メミキ"	POSITIONING (RIGHT)	
14-3-14	S19073001	2	イチキ"メヒタ"リ	POSITIONING (LEFT)	
14-3-15	007402512	8	ヒラネシ"4X25	SCREW 4X25	
14-3-16	028040243	8	ハ"ネサ"ガ"ネ2-4	SPRING WASHER 2-4	
14-3-17	S19074001	2	シリシタ"ーササエミキ"	CYLINDER SUPPORT (RIGHT)	
14-3-18	S19075001	2	シリシタ"ーササエヒタ"リ	CYLINDER SUPPORT (LEFT)	
14 3-19	062401012	8	ナヘ"COM4X10	SCREW M4X10	
14-3-20	028040242	8	ハ"ネサ"ガ"ネ2-4	SPRING WASHER 2-4	
14-3-21	S19076000	3	ウスガ"タシリシタ"クミA	THIN TYPE CYLINDER ASSEMBLY (A)	
14-3-21-1	S19078000	3	ウスガ"タシリシタ"12-5	THIN TYPE CYLINDER 12-5	
14-3-21-2	S12150000	6	ホースエルボ"M-5HL-4	TUBE ELBOW (M-5HL-4)	
14-3-22	S19077000	1	ウスガ"タシリシタ"クミB	THIN TYPE CYLINDER ASSEMBLY (B)	
14-3-22-1	S19078000	1	ウスガ"タシリシタ"12-5	THIN TYPE CYLINDER 12-5	
14-3-22-2	S11433000	2	ホースニツプル4M5	HOSE NIPPLE 4M5	
14-3-23	S12053000	8	CQ2ボルトM3X25	CQ2 BOLT M3X25	
14-3-24	028030243	8	ハ"ネサ"ガ"ネ2-3	SPRING WASHER 2-3	
14-3-25	018502022	8	アナボルト5X20	BOLT 5X20	
14-3-26	021500303	8	ナツト3シユ5	NUT 5	
14-3-27	S19540001	2	ト"ク"ミキ"	DOG (RIGHT)	
14-3-28	S19541001	2	ト"ク"ヒタ"リ	DOG (LEFT)	
14-3-29	062400806	8	ナヘ"コ4X8	SCREW 4X8	
14-3-30	025040233	8	ヒラサ"ガ"ネチユウ4	PLAIN WASHER 4	
14-3-31	028040243	8	ハ"ネサ"ガ"ネ2-4	SPRING WASHER 2-4	
14-3-32	S19512000	1	2レツセンサクミ	DOUBLE ROW SENSOR ASSEMBLY	
14-3-33	S19577---	1	ガイド"イターマル2	GUIDE PLATE (ROUND-2)	
14-3-34	S19542001	4	タンカラー	STAGE COLLAR	
14-3-35	S19543001	4	サ"ガ"ネ	WASHER	
14-3-36	062400806	4	ナヘ"コ4X8	SCREW 4X8	
14-3-37	028040243	4	ハ"ネサ"ガ"ネ2-4	SPRING WASHER 2-4	
14-3-38	S19544001	2	スヘーサー	SPACER	
14-3-39	S19076000	1	ウスガ"タシリシタ"クミA	THIN TYPE CYLINDER ASSEMBLY (A)	
14-3-39-1	S19078000	1	ウスガ"タシリシタ"12-5	THIN TYPE CYLINDER 12-5	
14-3-39-2	S12150000	2	ホースエルボ"M-5HL-4	TUBE ELBOW (M-5HL-4)	
14-3-40	S19545002	2	CQ2ボルトM3X35	CQ2 BOLT M3X35	
14-3-41	028030243	2	ハ"ネサ"ガ"ネ2-3	SPRING WASHER 2-3	
14-3-42	062400806	1	ナヘ"COM4X8	SCREW M4X8	
14-3-43	028040243	1	ハ"ネサ"ガ"ネ2-4	SPRING WASHER 2-4	
14-3-44	S19546001	1	シリシタ"ーササエ	CYLINDER SUPPORT	
14-3-45	062400806	2	ナヘ"コ4X8	SCREW 4X8	
14-3-46	028040243	2	ハ"ネサ"ガ"ネ2-4	SPRING WASHER 2-4	
14-3-47	025040233	5	ヒラサ"ガ"ネチユウ4	PLAIN WASHER 4	
14-3-48	S19547000	1	ツインシリシタ"クミ15	TWIN CYLINDER ASSEMBLY 15	
14-3-48-1	S19548000	1	ツインシリシタ"クミ12-15	TWIN CYLINDER 2-15	
14-3-48-2	S12150000	2	ホースエルボ"M-5HL-4	TUBE ELBOW (M-5HL-4)	
14-3-49	062402016	2	ナヘ"COM4X20	SCREW M4X20	

S. 折曲ケ関係 (特別注文部品)/Folding margin mechanism (Option parts)/Faltungsvorrichtung (Sonderzubehör)/
 Mécanisme de marge d'ourlet (Pièces en option)/Mecanismo de margen de plegado (Piezas a opción)

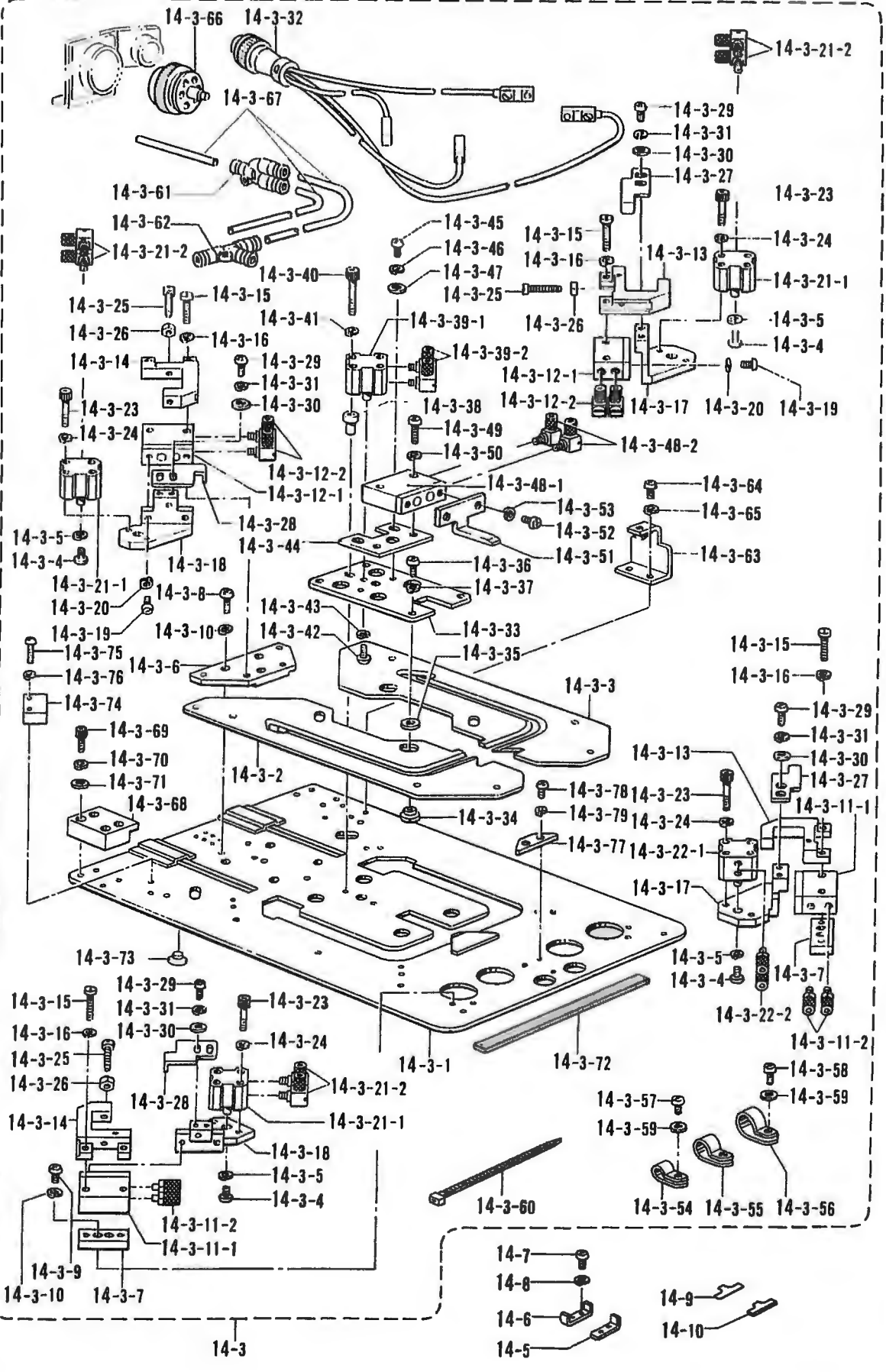

S. 折曲ゲ関係 (特別注文部品)/Folding margin mechanism (Option parts)/Faltungsvorrichtung (Sonderzubehör)/
 Mécanisme de marge d'ourlet (Pièces en option)/Mecanismo de margen de plegado (Piezas a opción)

RFF NO	CODE	Q'TY	品名	NAME OF PARTS	RMKS
14 3 50	028040243	2	ハ"ネサ"カ"ネ2-4	SPRING WASHER 2-4	
14 3 51	S19578	1	オサエナカ-マル2	INNER CLAMP (ROUND 2)	
14 3 52	062400806	2	ナヘ"コ4X8	SCREW 4X8	
14 3 53	028040243	2	ハ"ネサ"カ"ネ2-4	SPRING WASHER 2-4	
14 3 54	149547000	1	コード"オサエ 4N	CORD HOLDER 4N	
14 3 55	150826000	6	コード"オサエ 8N	CORD HOLDER 8N	
14 3 56	554482000	2	コード"ホルダ"12N	CORD HOLDER 12N	
14 3 57	062400616	7	ナヘ"コM4X6	SCREW M4X6	
14 3 58	062400806	2	ナヘ"コ4X8	SCREW 4X8	
14 3 59	025040233	9	ヒラサ"カ"ネチユウ4	PLAIN WASHER 4	
14-3 60	S04159000	2	バンド"1M	BAND 1M	
14 3 61	S19557000	10	コカ"タユニオンワイ4	MINIATURE UNION-Y 4	
14 3 62	S19558000	4	コカ"タチ-ス"4	MINIATURE T-JOINT-4	
14-3 63	S19552001	1	チューブ"ササエA	TUBE SUPPORT (A)	
14 3 64	062400616	2	ナヘ"コM4X6	SCREW M4X6	
14 3 65	028040243	2	ハ"ネサ"カ"ネ2-4	SPRING WASHER 2-4	
14-3-66	S19549000	1	マルチコネクター-6P	MULTI CONNECTOR (6P)	
14-3 67	S19551000	1	エア-ホース4X2.5-W	AIR TUBE 4X2.5-W (L=6000)	
14 3 68	S12110001	2	コネクトブロック(オサエ)	CONNECT BLOCK (PRESSER)	
14 3 69	018401022	8	アナボ"ルト4X10	BOLT 4X10	
14-3 70	028040242	8	ハ"ネサ"カ"ネ2-4	SPRING WASHER 2-4	
14-3 71	025040232	8	ヒラサ"カ"ネチユウ4	PLAIN WASHER 4	
14-3-72	S12298000	2	フォーム3X15X1000	FORM 3X15X1000	
14-3-73	S12279000	6	ウケイタ(オサエ)	SUPPORT PLATE (PRESSER)	
14-3-74	S20890000	2	オサエガイド"1	PRESSER GUIDE 1	
14-3-75	062401416	4	ナヘ"コ4X14	SCREW 4X14	
14-3-76	028040243	4	ハ"ネサ"カ"ネ2-4	SPRING WASHER 2-4	
14-3-77	S20891000	1	オサエガイド"2	PRESSER GUIDE 2	
14-3-78	062400806	2	ナヘ"コ4X8	SCREW 4X8	
14-3-79	028040243	2	ハ"ネサ"カ"ネ2-4	SPRING WASHER 2-4	
14-5	S12111001	3	スリットC	SLIT (C)	
14-6	S12112001	3	スリットD	SLIT (D)	
14-7	062300502	6	ナヘ"コ3X5	SCREW 3X5	
14-8	028030242	6	ハ"ネサ"カ"ネ2-3	SPRING WASHER 2-3	
14-9	S16514000	2	スペーサ0.05	SPACER 0.05	
14-10	S16513000	2	スペーサ0.1	SPACER 0.1	

S. 折曲ゲ関係 (特別注文部品)/Folding margin mechanism (Option parts)/Faltungsvorrichtung (Sonderzubehör)/
 Mécanisme de marge d'ourlet (Pièces en option)/Mecanismo de margen de plegado (Piezas a opción)

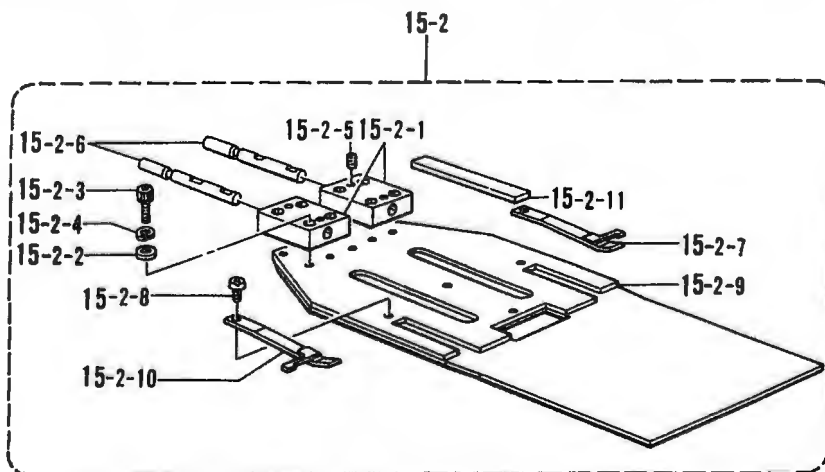
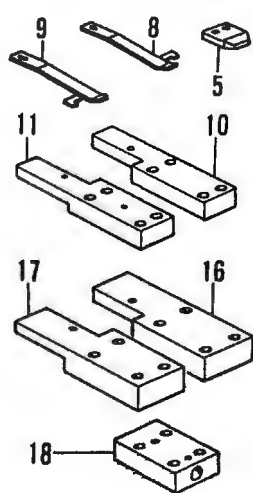
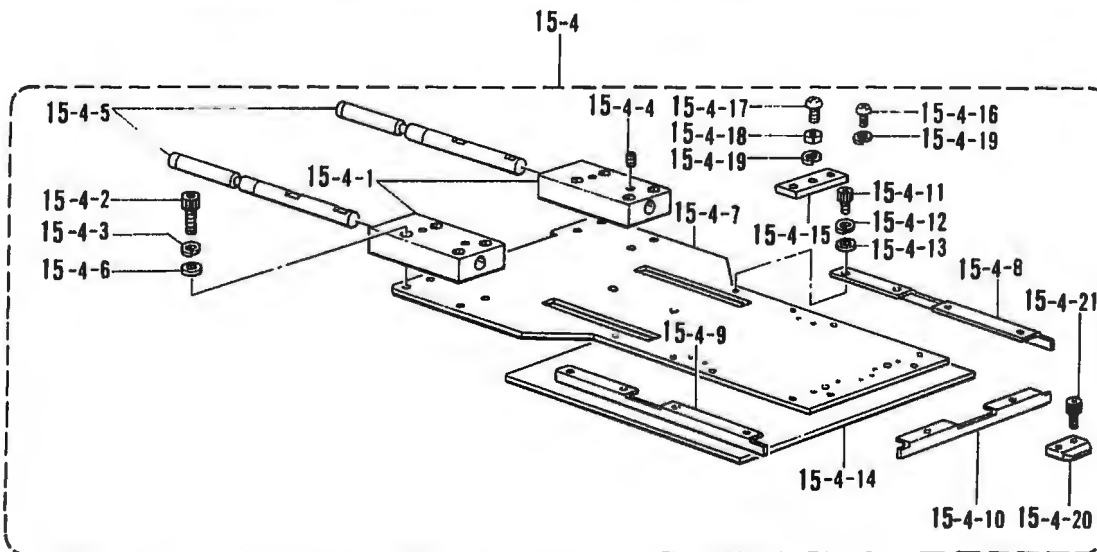
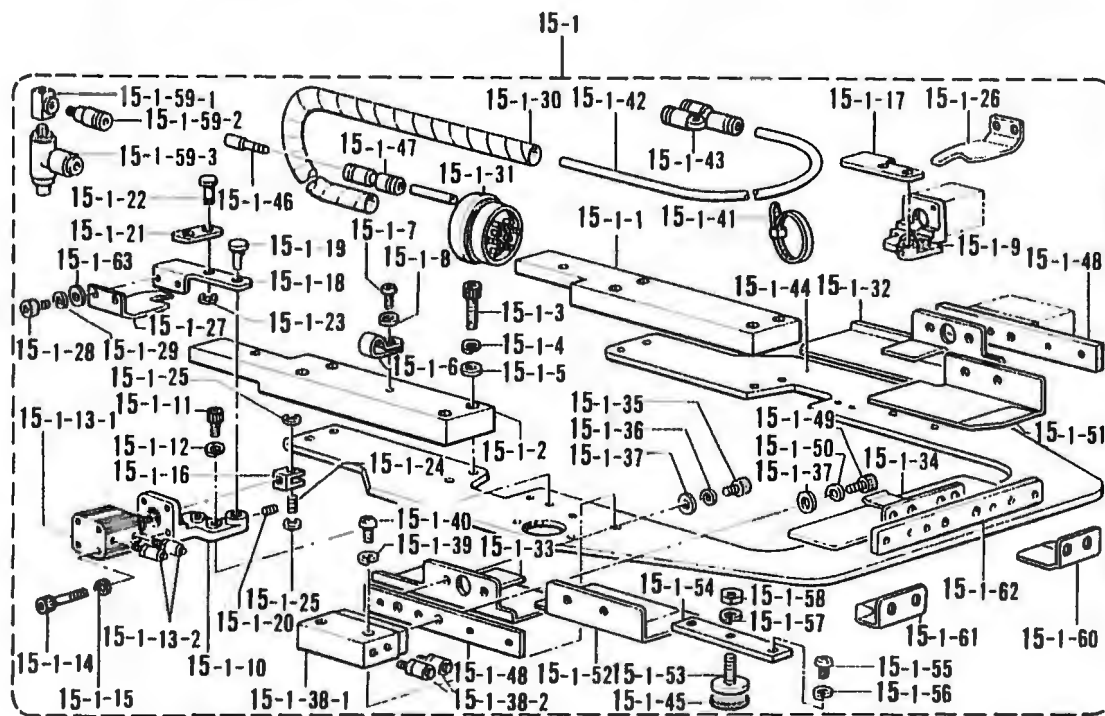

S. 折曲ゲ関係 (特別注文部品)/Folding margin mechanism (Option parts)/Faltungsvorrichtung (Sonderzubehör)/
 Mécanisme de marge d'ourlet (Pièces en option)/Mecanismo de margen de plegado (Piezas a opción)

RII NO	CODE	O'TY	ヒンメイ	NAME OF PARTS	RMKS
15	S19579	1	オリキクミ-4カク2	FOLDING GROUP ASSEMBLY (SQUARE-2)	
15 1	S12342	1	オリササエクミ-4カク	FOLDING CLAMP ASSEMBLY (SQUARE)	
15 1 1	S12086001	1	コネクタブ"ロツクR	CONNECT BLOCK (R)	
15 1 2	S12087001	1	コネクタブ"ロツクL	CONNECT BLOCK (L)	
15 1 3	018502522	8	アナホ"ルト5X25	BOLT 5X25	
15 1 4	028050242	8	ハ"ネサ"カ"ネ2-5	SPRING WASHER 2-5	
15 1 5	025050232	8	ヒラサ"カ"ネチユウ-5	PLAIN WASHER 5	
15 1 6	525907000	1	コート"ホルタ"9N	CORD HOLDER 9N	
15 1 7	062401006	1	ナヘ"コ4X10	SCREW 4X10	
15 1 8	025040233	1	ヒラサ"カ"ネチユウ4	PLAIN WASHER 4	
15 1 9	S12088009	1	レハ"-ヘ"-スR	LEVER BASE (R)	
15 1 10	S12089009	1	レハ"-ヘ"-スL	LEVER BASE (L)	
15 1 11	018401222	4	アナホ"ルト4X12	BOLT 4X12	
15 1 12	028040242	4	ハ"ネサ"カ"ネ2-4	SPRING WASHER 2-4	
15 1 13	S12090000	2	シリンタ"-12X10クミ	CYLINDER 12X10 ASSEMBLY	
15 1 13 1	S12091000	2	シリンタ"-12X10	CYLINDER 12X10	
15 1 13-2	S11433000	4	ホ-スニツプ"ル4M5	HOSE NIPPLE 4M5	
15 1 14	S12092000	8	CQ2ホ"ルトM3X30	CQ2 BOLT M3X30	
15-1 15	028030243	8	ハ"ネサ"カ"ネ2-3	SPRING WASHER 2-3	
15-1-16	S12093001	2	ナツクル	KNUCKLE	
15-1 17	S12094001	1	ヒンシ"R	HINGE (R)	
15-1-18	S12095001	1	ヒンシ"L	HINGE (L)	
15-1 19	S12096001	2	ヒンシ"ピン	PIN	
15-1 20	014400522	2	アナホ"ミ34X5	SET SCREW 4X5	
15-1 21	S12097001	2	タイフ"レート	TIE PLATE	
15-1 22	S12098001	2	ピン	PIN	
15-1 23	048050342	2	トメフE5	STOP RING E5	
15-1 24	S12099001	2	ナツクル"ピン	PIN	
15-1 25	048050342	4	トメフE5	STOP RING E5	
15-1 26	S12475100	1	メントリイタR"タイ	TUCKING BLADE (R) LARGE	
15-1 27	S12476100	1	メントリイタL"タイ	TUCKING BLADE (L) LARGE	
15-1 28	018400632	4	アナホ"ルト4X6	BOLT 4X6	
15-1 29	028040242	4	ハ"ネサ"カ"ネ2-4	SPRING WASHER 2-4	
15-1 30	S12214000	1	スパイラル640L	SPIRAL 640L	
15-1 31	S12106000	1	マルチコネクタP	MULTI CONNECTOR (P)	
15-1 32	S12343---	1	オリイタR-4カク	TUCKING BLADE (R) (SQUARE)	
15-1 33	S12344---	1	オリイタL-4カク	TUCKING BLADE (L) (SQUARE)	
15-1 34	S12345---	1	オリイタD-4カク	TUCKING BLADE (D) (SQUARE)	
15-1 35	018400632	14	アナホ"ルト4X6	BOLT 4X6	
15-1 36	028040242	14	ハ"ネサ"カ"ネ2-4	SPRING WASHER 2-4	
15-1 37	025040232	18	ヒラサ"カ"ネチユウ4	PLAIN WASHER 4	
15-1 38	S12102000	3	ツインロッド"シリンタ"クミ	TWIN ROD CYLINDER ASSEMBLY	
15-1 38-1	S12103000	3	ツインロッド"シリンタ"	TWIN ROD CYLINDER	
15-1 38-2	S11433000	6	ホ-スニツプ"ル4M5	HOSE NIPPLE 4M5	
15-1 39	028040243	6	ハ"ネサ"カ"ネ2-4	SPRING WASHER 2-4	
15-1 40	062402016	6	ナヘ"コM4X20	SCREW M4X20	
15-1 41	S04159000	2	バンド"1M	BAND 1M	
15-1 42	S12205000	1	エアホ-ス4X2.5-29	AIR TUBE 4X2.5-29 (L=7500)	
15-1 43	S12104000	4	ユニオンワイ4	UNION-Y 4	
15-1 44	S12346---	1	オリササエ-4カク	FOLDING CLAMP (SQUARE)	
15-1 45	S12297000	2	スホ"ンシ"2-30	SPONGE 2-30	
15-1 46	S04897000	2	メクラセシ	BLIND CAP	
15-1 47	S04587000	2	ストレートツキ"テ	STRAIGHT JOINT	
15-1 48	S12469---	2	オリイタササエ-4カク	FOLDING PLATE SUPPORT (SQUARE)	
15-1 49	018400832	6	アナホ"ルト4X8	BOLT 4X8	
15-1 50	028040242	6	ハ"ネサ"カ"ネ2-4	SPRING WASHER 2-4	
15-1 51	S12470---	1	オリイタRD-4カク	TUCKING BLADE (RD) (SQUARE)	
15-1 52	S12471---	1	オリイタLD-4カク	TUCKING BLADE (LD) (SQUARE)	
15-1 53	S12291001	2	アジ"ヤストネシ"	ADJUST SCREW	
15-1 54	S12294001	2	トリツケイタ(オリササエ)	FITTING PLATE (FOLDING CLAMP)	
15-1 55	062401006	4	ナヘ"コ4X10	SCREW 4X10	
15-1 56	028040243	4	ハ"ネサ"カ"ネ2-4	SPRING WASHER 2-4	

S. 折曲ヶ関係 (特別注文部品)/Folding margin mechanism (Option parts)/Faltungsvorrichtung (Sonderzubehör)/
 Mécanisme de marge d'ourlet (Pièces en option)/Mecanismo de margen de plegado (Piezas a opción)

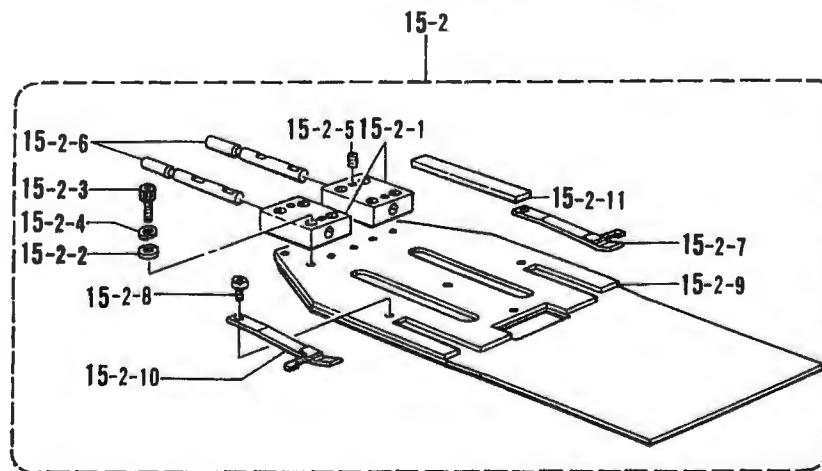
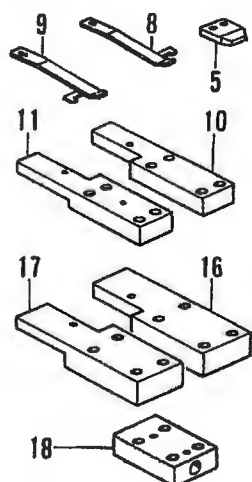
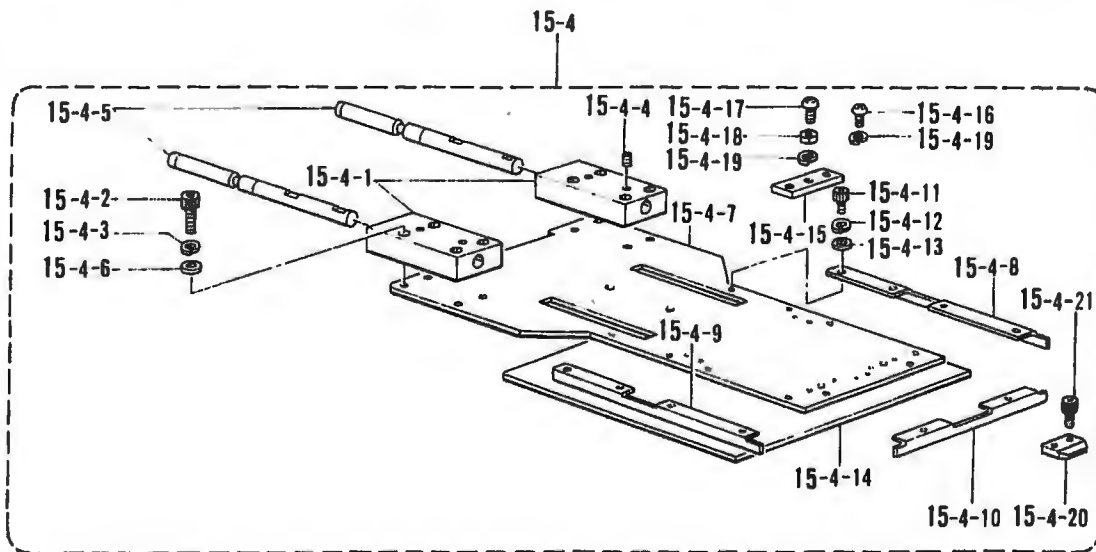
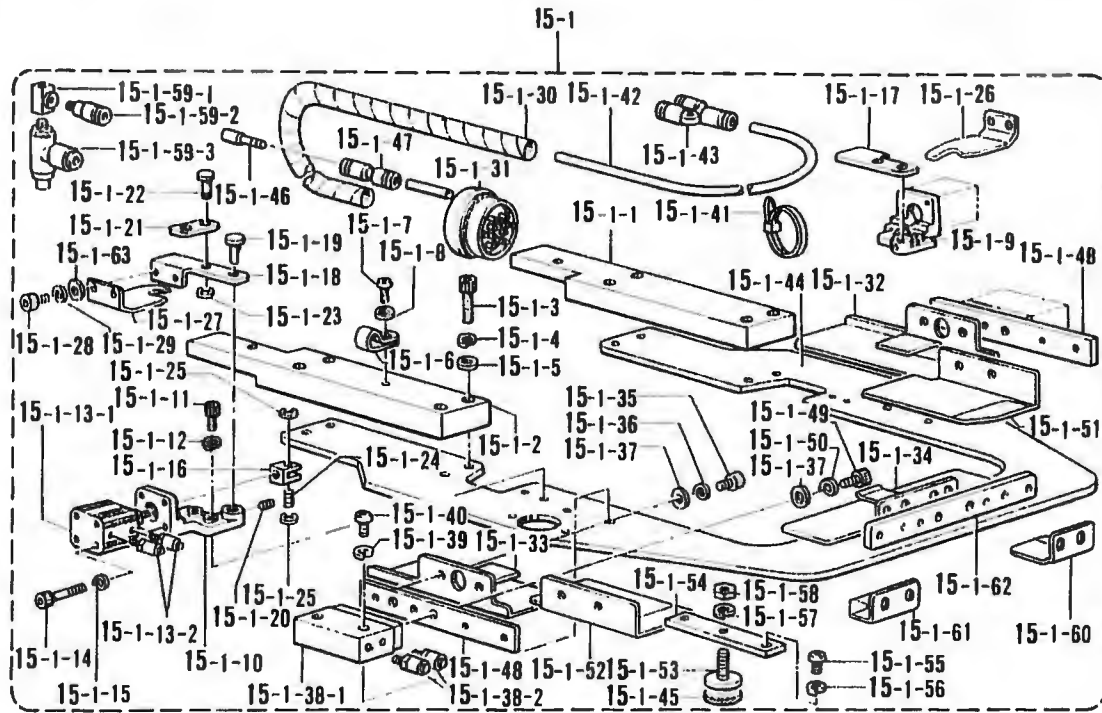

S. 折り目の機構 (特別注文部品)/Folding margin mechanism (Option parts)/Faltungsvorrichtung (Sonderzubehör)/
Mécánisme de marge d'ourlet (Pièces en option)/Mecanismo de margen de plegado (Piezas a opción)

REF NO	CODE	Q'TY	ヒンメイ	NAME OF PARTS	RMKS
15 1 57	028060243	2	ハ"ネサ"カ"ネ2-6	SPRING WASHER 2 6	
15 1 58	021060206	2	ナツト2シユ6	NUT 6	
15 1 59	S15564000	1	チ-M5クミ	T-M5 ASSEMBLY	
15 1 59 1	S15563000	1	チ-M5	T M5	
15 1 59 2	S04905000	1	ハ-フユニオン	HALF UNION	
15 1 59 3	S14328000	2	シボ"リヘン	THROTTLE VALVE	
15 1 60	S16515	1	オリイタRDD-4カク	TUCKING BLADE (RDD) (SQUARE)	
15 1 61	S16516	1	オリイタLDD-4カク	TUCKING BLADE (LDD) (SQUARE)	
15 1 62	S16517	1	オリイタササID-4カク	TUCKING BLADE SUPPORT (D) (SQUARE)	
15 1 63	025040132	6	ヒラサ"カ"ネシヨウ4	PLAIN WASHER 4	
15 2	S12347	1	ケ-シ"クミ-4カク	CENTER BLADE ASSEMBLY (SQUARE)	
15 2 1	S12107001	2	コネクトフ"ロツク(ケ-シ")	CONNECT BLOCK (CENTER BLADE) (GAGE)	
15 2 2	025040232	8	ヒラサ"カ"ネチユウ4	PLAIN WASHER 4	
15 2 3	018402032	8	アナホ"ルト4X20	BOLT 4X20	
15 2 4	028040242	8	ハ"ネサ"カ"ネ2-4	SPRING WASHER 2-4	
15 2 5	014500522	4	アナトメネシ"5クホ"ミ	SET SCREW 5	
15 2 6	S12108001	2	コネクトピン(ケ-シ")	PIN (CENTER BLADE) (GAGE)	
15 2 7	S12109000	1	イタハ"ネR	PLATE SPRING (R)	
15 2 8	062300414	2	ハ"イント"3X4	SCREW 3X4	
15 2 9	S12348...	1	ケ-シ"-4カク	CENTER BLADE (SQUARE)	
15 2 10	S12105000	1	イタハ"ネL	PLATE SPRING (L)	
15 2 11	S12278000	2	ウケイタ(ケ-シ")	SUPPORT PLATE (CENTER BLADE) (GAGE)	
15 4	S12351...	1	ナカオサイクミ-4カク	INNER CLAMP ASSEMBLY (SQUARE)	
15 4 1	S12113001	2	コネクトフ"ロツク(ナカ)	CONNECT BLOCK (INNER)	
15 4 2	018502522	8	アナホ"ルト5X25	BOLT 5X25	
15 4 3	028050242	8	ハ"ネサ"カ"ネ2-5	SPRING WASHER 2-5	
15 4 4	014500522	4	アナトメネシ"5クホ"ミ	SET SCREW 5	
15 4 5	S12114001	2	コネクトピン(ナカ)	PIN (INNER)	
15 4 6	025050232	8	ヒラサ"カ"ネチユウ-5	PLAIN WASHER 5	
15 4 7	S12352...	1	ナカオサI-4カク	INNER CLAMP (SQUARE)	
15 4 8	S12353...	1	ナカオサIウI1-4カク	INNER CLAMP UPPER 1 (SQUARE)	
15 4 9	S12354...	1	ナカオサIウI2-4カク	INNER CLAMP UPPER 2 (SQUARE)	
15 4 10	S12355...	1	ナカオサIウI3-4カク	INNER CLAMP UPPER 3 (SQUARE)	
15 4 11	018300532	6	アナホ"ルト3X5	BOLT 3X5	
15 4 12	028030242	6	ハ"ネサ"カ"ネ2-3	SPRING WASHER 2-3	
15 4 13	025030232	6	ヒラサ"カ"ネチユウ3	PLAIN WASHER 3	
15 4 14	S12117000	1	フォーム2X200X200	FORM 2X200X200	
15 4 15	S12485001	2	トリツケイタ(ナカオサI)	FITTING PLATE (INNER CLAMP)	
15 4 16	062400806	4	ナヘ"コ4X8	SCREW 4X8	
15 4 17	062401416	2	ナヘ"コ4X14	SCREW 4X14	
15 4 18	021400103	2	ナツト1シユ4	NUT 4	
15 4 19	028040243	6	ハ"ネサ"カ"ネ2-4	SPRING WASHER 2-4	
15 4 20	S12487000	3	オリイタウケ(ナカオサI)	FOLDING PLATE SUPPORT (INNER CLAMP)	
15 4 21	018300532	6	アナホ"ルト3X5	BOLT 3X5	
5	S12494000	1	オリイタウケシヨウ	FOLDING PLATE SUPPORT (SMALL)	
8	S15565000	1	イタハ"ネR0.8	PLATE SPRING (R) 0.8	
9	S15566000	1	イタハ"ネL0.8	PLATE SPRING (L) 0.8	
10	S12507001	1	コネクトフ"ロツクSR	CONNECT BLOCK (SR)	
11	S12508001	1	コネクトフ"ロツクSL	CONNECT BLOCK (SL)	
16	S21121001	1	コネクトフ"ロツクSSR	CONNECT BLOCK (SSR)	
17	S21122001	1	コネクトフ"ロツクSSL	CONNECT BLOCK (SSL)	
18	S21123001	2	コネクトフ"ロツクS	CONNECT BLOCK (S)	

S. 折曲ゲ関係 (特別注文部品)/Folding margin mechanism (Option parts)/Faltungsvorrichtung (Sonderzubehör)/
Mécánisme de marge d'ourlet (Pièces en option)/Mecanismo de margen de plegado (Piezas a opción)

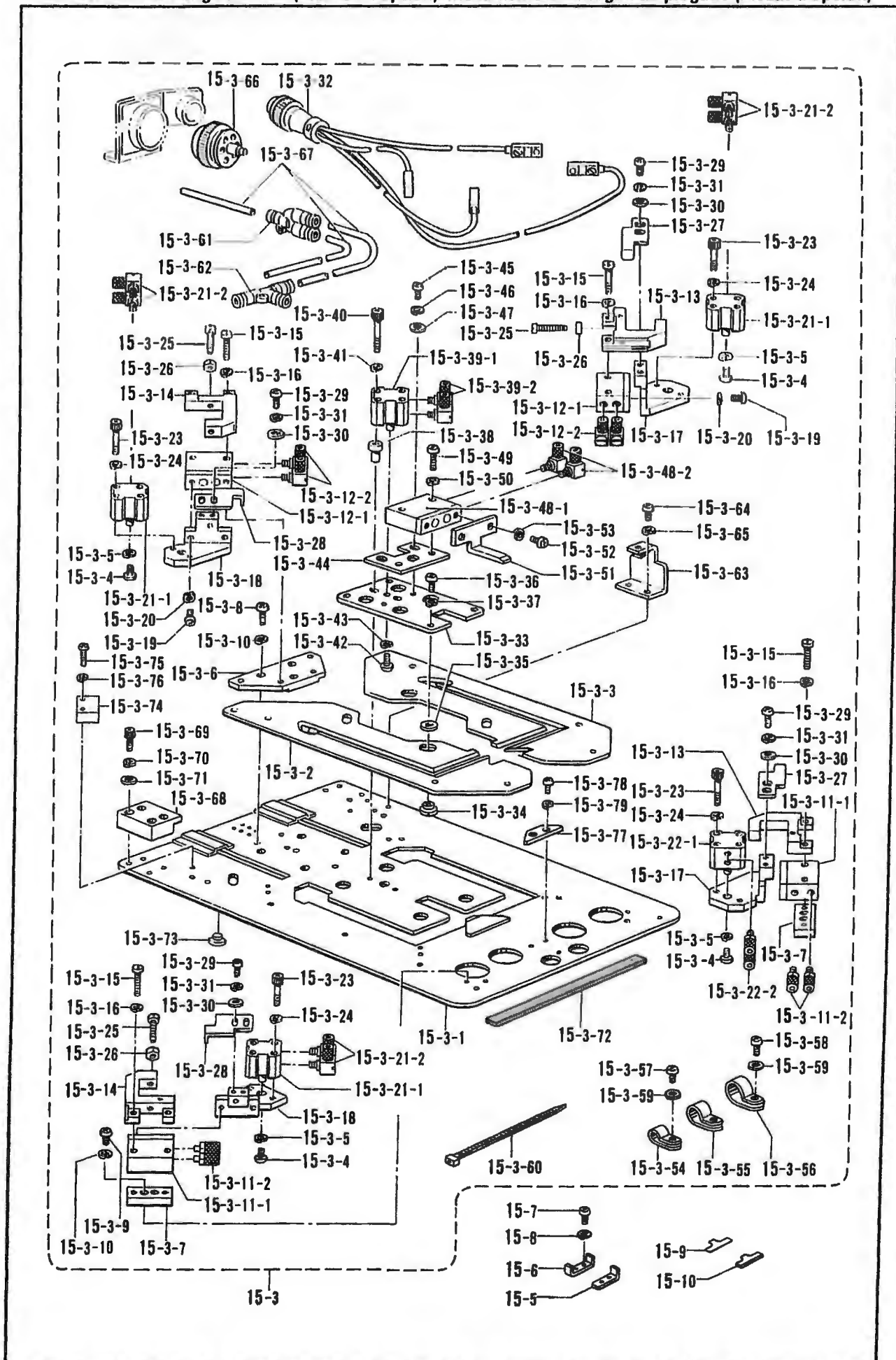

S. 折曲ゲ関係 (特別注文部品)/Folding margin mechanism (Option parts)/Faltungsvorrichtung (Sonderzubehör)/
Mécánisme de marge d'ourlet (Pièces en option)/Mecanismo de margen de plegado (Piezas a opción)

REF NO	CODE	Q'TY	品名	NAME OF PARTS	RMKS
15 3	S19672	1	オサエクミ-4カク2	SEWING CLAMP ASSEMBLY (SQUARE-2)	
15 3 1	S19580	1	オサエシター-4カク2	SEWING CLAMP LOWER (SQUARE-2)	
15 3 2	S19581	1	オサエヒタリ-4カク2	SEWING CLAMP LEFT (SQUARE-2)	
15 3 3	S19582	1	オサエミキ-4カク2	SEWING CLAMP RIGHT (SQUARE-2)	
15 3 4	062400616	4	ナヘ"コM4X6	SCREW M4X6	
15 3 5	028040743	4	ハ"ネサ"カ"ネ2-4	SPRING WASHER 2-4	
15 3 6	S19069001	1	スヘ-サB	SPACER (B)	
15 3 7	S19070000	2	スヘ-サA	SPACER (A)	
15 3 8	062401016	3	ナヘ"コ4X10	SCREW 4X10	
15 3 9	062400616	4	ナヘ"コM4X6	SCREW M4X6	
15 3 10	028040243	7	ハ"ネサ"カ"ネ2-4	SPRING WASHER 2-4	
15 3 11	S12102000	2	ツインロッド"シリンドラ"クミ	TWIN ROD CYLINDER ASSEMBLY (A)	
15 3 11-1	S12103000	2	ツインロッド"シリンドラ"	TWIN ROD CYLINDER	
15 3 11-2	S11433000	4	ホ-スニツツ"ル4M5	HOSE NIPPLE 4M5	
15 3 12	S19071000	2	ツインロッド"シリンドラ"クミB	TWIN ROD CYLINDER ASSEMBLY (B)	
15 3 12 1	S12103000	2	ツインロッド"シリンドラ"	TWIN ROD CYLINDER	
15 3 12-2	S12150000	4	ホ-スエルボ"M-5HL-4	TUBE ELBOW (M-5HL-4)	
15 3 13	S19072001	2	イチキ"メミキ"	POSITIONING (RIGHT)	
15 3 14	S19073001	2	イチキ"メヒタリ"	POSITIONING (LEFT)	
15 3 15	007402512	8	ヒラネジ"4X25	SCREW 4X25	
15-3-16	028040243	8	ハ"ネサ"カ"ネ2-4	SPRING WASHER 2-4	
15-3-17	S19074001	2	シリンドラ-ササエミキ"	CYLINDER SUPPORT (RIGHT)	
15-3-18	S19075001	2	シリンドラ-ササエヒタリ"	CYLINDER SUPPORT (LEFT)	
15-3-19	062401012	8	ナヘ"コM4X10	SCREW M4X10	
15-3-20	028040242	8	ハ"ネサ"カ"ネ2-4	SPRING WASHER 2-4	
15 3 21	S19076000	3	ウスカ"タシリンドラ"クミA	THIN TYPE CYLINDER ASSEMBLY (A)	
15-3-21-1	S19078000	3	ウスカ"タシリンドラ"12-5	THIN TYPE CYLINDER 12-5	
15-3-21-2	S12150000	6	ホ-スエルボ"M-5HL-4	TUBE ELBOW (M-5HL-4)	
15-3-22	S19077000	1	ウスカ"タシリンドラ"クミB	THIN TYPE CYLINDER ASSEMBLY (B)	
15-3-22-1	S19078000	1	ウスカ"タシリンドラ"12-5	THIN TYPE CYLINDER 12-5	
15-3-22-2	S11433000	2	ホ-スニツツ"ル4M5	HOSE NIPPLE 4M5	
15-3-23	S12053000	8	CQ2ボルトM3X25	CQ2 BOLT M3X25	
15-3-24	028030243	8	ハ"ネサ"カ"ネ2-3	SPRING WASHER 2-3	
15-3-25	018502022	8	アナボルト5X20	BOLT 5X20	
15-3-26	021500303	8	ナツト3シユ5	NUT 5	
15-3-27	S19540001	2	ト"ク"ミキ"	DOG (RIGHT)	
15-3-28	S19541001	2	ト"ク"ヒタリ"	DOG (LEFT)	
15-3-29	062400806	8	ナヘ"コ4X8	SCREW 4X8	
15-3-30	025040233	8	ヒラサ"カ"ネチユウ4	PLAIN WASHER 4	
15-3-31	028040243	8	ハ"ネサ"カ"ネ2-4	SPRING WASHER 2-4	
15-3-32	S19512000	1	2レツセンサクミ	DOUBLE ROW SENSOR ASSEMBLY	
15-3-33	S19583000	1	カ"イト"イター-4カク2	GUIDE PLATE (SQUARE-2)	
15-3-34	S19542001	4	タ"ンカラ-	STAGE COLLAR	
15-3-35	S19543001	4	サ"カ"ネ	WASHER	
15-3-36	062400806	4	ナヘ"コ4X8	SCREW 4X8	
15-3-37	028040243	4	ハ"ネサ"カ"ネ2-4	SPRING WASHER 2-4	
15-3-38	S19544001	2	スヘ-サー	SPACER	
15-3-39	S19076000	1	ウスカ"タシリンドラ"クミA	THIN TYPE CYLINDER ASSEMBLY (A)	
15-3-39-1	S19078000	1	ウスカ"タシリンドラ"12-5	THIN TYPE CYLINDER 12-5	
15-3-39-2	S12150000	2	ホ-スエルボ"M-5HL-4	TUBE ELBOW (M-5HL-4)	
15-3-40	S19545002	2	CQ2ボルトM3X35	CQ2 BOLT M3X35	
15-3-41	028030243	2	ハ"ネサ"カ"ネ2-3	SPRING WASHER 2-3	
15-3-42	062400806	1	ナヘ"コM4X8	SCREW M4X8	
15-3-43	028040243	1	ハ"ネサ"カ"ネ2-4	SPRING WASHER 2-4	
15-3-44	S19546001	1	シリンドラ-ササエ	CYLINDER SUPPORT	
15-3-45	062400806	2	ナヘ"コ4X8	SCREW 4X8	
15-3-46	028040243	2	ハ"ネサ"カ"ネ2-4	SPRING WASHER 2-4	
15-3-47	025040233	5	ヒラサ"カ"ネチユウ4	PLAIN WASHER 4	
15-3-48	S19547000	1	ツインシリンドラ"クミ15	TWIN CYLINDER ASSEMBLY 15	
15-3-48-1	S19548000	1	ツインシリンドラ"クミ12-15	TWIN CYLINDER 12-15	
15-3-48-2	S12150000	2	ホ-スエルボ"M-5HL-4	TUBE ELBOW (M-5HL-4)	
15-3-49	062402016	2	ナヘ"コM4X20	SCREW M4X20	

S. 折曲ヶ関係 (特別注文部品) / Folding margin mechanism (Option parts) / Faltungsvorrichtung (Sonderzubehör) /
 Mécanisme de marge d'ourlet (Pièces en option) / Mecanismo de margen de plegado (Piezas a opción)

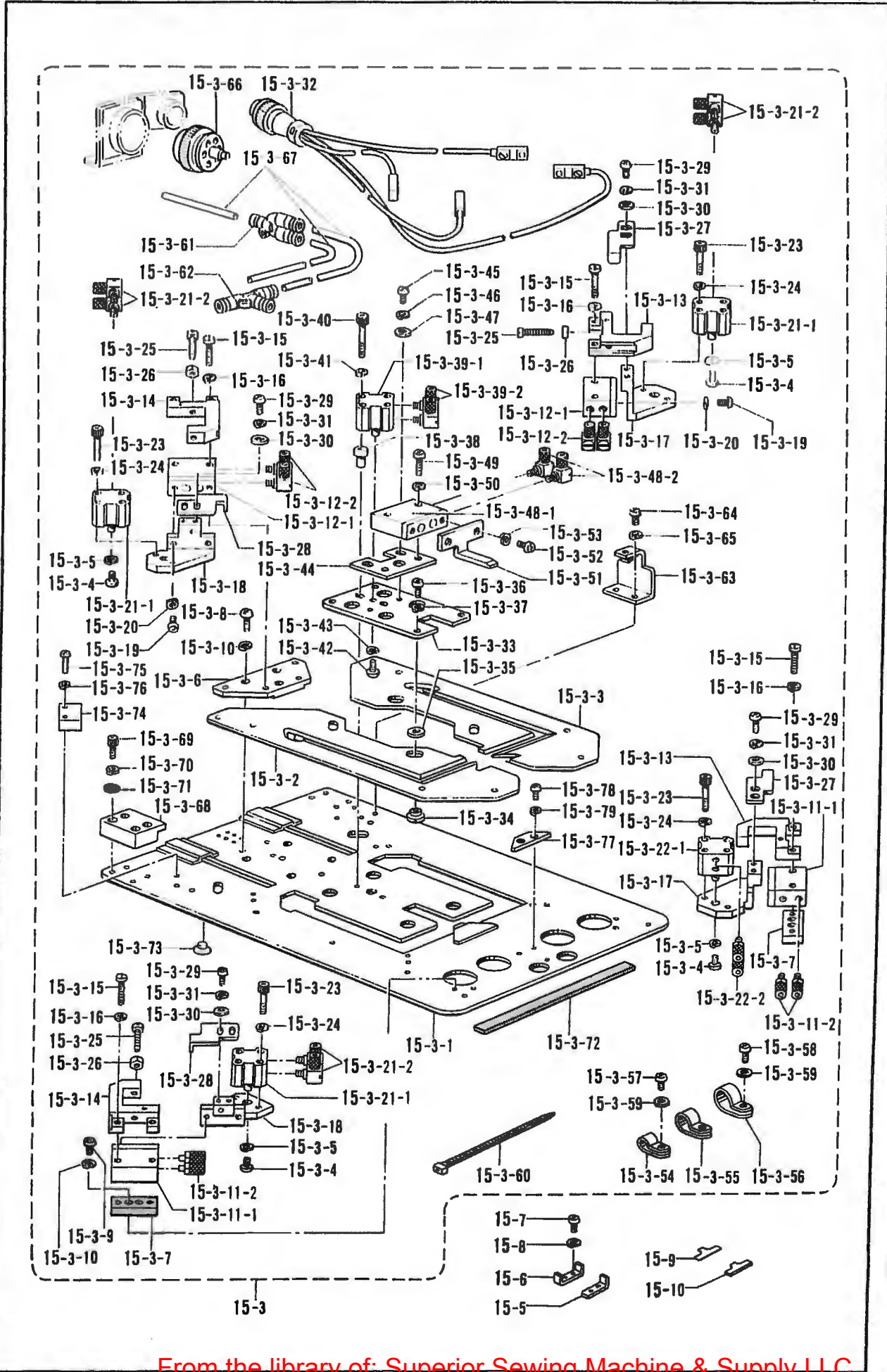

S. 折曲ゲ関係 (特別注文部品)/Folding margin mechanism (Option parts)/Faltungsvorrichtung (Sonderzubehör)/
 Mécanisme de marge d'ourlet (Pièces en option)/Mecanismo de margen de plegado (Piezas a opción)

REF NO	CODE	Q'TY	品名	NAME OF PARTS	RMKS
15 3 50	028040243	2	ハ"ネサ"カ"ネ2-4	SPRING WASHER 2 4	
15 3 51	S19584	1	オサエナカ-4カク2	INNER CLAMP (SQUARE-2)	
15 3 52	062400806	2	ナヘ"コ4X8	SCREW 4X8	
15 3 53	028040243	2	ハ"ネサ"カ"ネ2-4	SPRING WASHER 2-4	
15 3 54	149547000	1	コート"オサエ 4N	CORD HOLDER 4N	
15 3 55	150826000	6	コート"オサエ 8N	CORD HOLDER 8N	
15 3 56	554482000	2	コート"ホルタ"12N	CORD HOLDER 12N	
15 3 57	062400616	7	ナヘ"コM4X6	SCREW M4X6	
15 3 58	062400806	2	ナヘ"コ4X8	SCREW 4X8	
15 3 59	025040233	9	ヒラサ"カ"ネチユウ4	PLAIN WASHER 4	
15 3 60	S04159000	2	ハ"ント"1M	BAND 1M	
15 3 61	S19557000	10	コカ"タユニオンワイ4	MINIATURE UNION-Y 4	
15 3 62	S19558000	4	コカ"タチース"4	MINIATURE T-JOINT-4	
15 3 63	S19552001	1	チューブ"ササエA	TUBE SUPPORT (A)	
15 3 64	062400616	2	ナヘ"コM4X6	SCREW M4X6	
15 3 65	028040243	2	ハ"ネサ"カ"ネ2-4	SPRING WASHER 2-4	
15 3 66	S19549000	1	マルチコネクター-6P	MULTI CONNECTOR (6P)	
15 3 67	S19551000	1	エア-ホース4X2.5-W	AIR TUBE 4X2.5-W (L- 6000)	
15 3 68	S12110001	2	コネクトブロック(オサエ)	CONNECT BLOCK (PRESSER)	
15 3 69	018401022	8	アナボ"ルト4X10	BOLT 4X10	
15 3 70	028040242	8	ハ"ネサ"カ"ネ2-4	SPRING WASHER 2-4	
15 3 71	025040232	8	ヒラサ"カ"ネチユウ4	PLAIN WASHER 4	
15 3 72	S12298000	2	フォーム3X15X1000	FORM 3X15X1000	
15 3 73	S12279000	6	ウケイタ(オサエ)	SUPPORT PLATE (PRESSER)	
15 3 74	S20890000	2	オサエガイド"1	PRESSER GUIDE 1	
15 3 75	062401416	4	ナヘ"コ4X14	SCREW 4X14	
15 3 76	028040243	4	ハ"ネサ"カ"ネ2-4	SPRING WASHER 2-4	
15 3 77	S20891000	1	オサエガイド"2	PRESSER GUIDE 2	
15 3 78	062400806	2	ナヘ"コ4X8	SCREW 4X8	
15 3 79	028040243	2	ハ"ネサ"カ"ネ2-4	SPRING WASHER 2-4	
15-5	S12111001	3	スリットC	SLIT (C)	
15-6	S12112001	3	スリットD	SLIT (D)	
15-7	062300502	6	ナヘ"コ3X5	SCREW 3X5	
15-8	028030242	6	ハ"ネサ"カ"ネ2-3	SPRING WASHER 2-3	
15-9	S16514000	2	スペーサ0.05	SPACER 0.05	
15-10	S16513000	2	スペーサ0.1	SPACER 0.1	

T. 折曲ゲ土台関係 / Folding margin base mechanism / Faltungsvorrichtunggrundplatte / Mécanisme de base de marge d'ourlet / Mecanismo base de margen de plegado

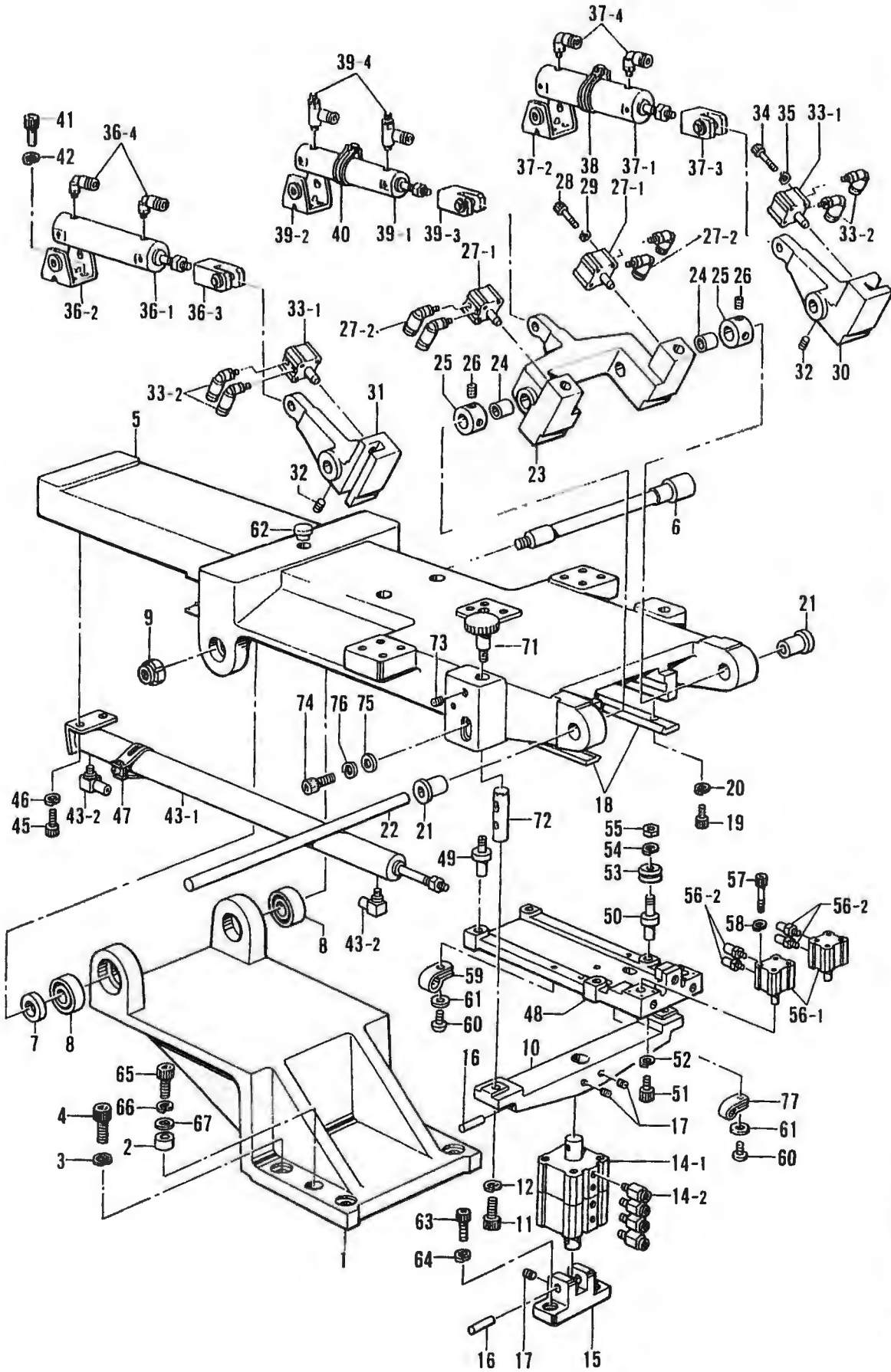

T. 折曲ケ土台関係/Folding margin base mechanism/Faltungsvorrichtunggrundplatte/
Mécánisme de base de marge d'ourlet/Mecanismo base de margen de plegado

REF NO	CODE	Q'TY	ヒンメイ	NAME OF PARTS	RMKS
1	S15532009	1	ヒンシ"ト"タイ	HINGE BASE	
2	S12119001	2	ピン	PIN	
3	028080242	4	ハ"ネサ"カ"ネ2-8	SPRING WASHER 2 8	
4	018082522	4	アナボ"ルト8X25	BOLT 8X25	
5	S15556009	1	オリト"タイ	FOLDING BASE	
6	S15530001	1	オリト"タイシ"ク	FOLDING BASE SHAFT	
7	S15531001	1	オリト"タイイ"カラー	FOLDING BASE COLLAR	
8	S12123000	2	アンキ"ユラタマシ"クウク2	ANGULAR BALL BEARING 2	
9	S04782000	1	フ"インU"ナツトSS-AN02	FAIN (U) NUT SS-AN02	
10	S15542109	1	オリト"タイヒンシ"ウエ	FOLDING BASE HINGE UPPER	
11	018081622	2	アナボ"ルト8X16	BOLT 8X16	
12	028080242	2	ハ"ネサ"カ"ネ2-8	SPRING WASHER 2-8	
14	S12125000	1	ウスカ"タシリンダ"-ABクミ	THIN TYPE CYLINDER (AB) ASSEMBLY	
14-1	S12126000	1	ウスカ"タシリンダ"-AB	THIN TYPE CYLINDER (AB)	
14-2	S04910000	4	ハーフユニオン	HALF UNION	
15	S12127109	1	オリト"タイヒンシ"	FOLDING BASE HINGE	
16	S12128101	2	オリト"タイヒンシ"シ"ク	FOLDING BASE HINGE SHAFT	
17	014500522	4	ア"ナトメネシ"5クホ"ミ	SET SCREW 5	
18	S12129000	2	トラツクレール	TRACK RAIL	
19	018400832	20	アナボ"ルト4X8	BOLT 4X8	
20	028040242	20	ハ"ネサ"カ"ネ2-4	SPRING WASHER 2-4	
21	S12130000	2	フ"ランシ"フ"ツシユ1520	FLANGE BUSH 1520	
22	S12131000	1	LMシヤフト15	LM SHAFT 15	
23	S12132009	1	ナカオサエ"ハ"	INNER CLAMP LEVER	
24	S12133000	2	フ"ツシユ1512	BUSH 1512	
25	S12134001	2	ナカオサエ"カラー	INNER CLAMP COLLAR	
26	014060632	4	ア"ナトメ6X6クホ"ミ	SET SCREW 6X6	
27	S12135000	2	ロックシリンダ"-クミB	LOCK CYLINDER ASSEMBLY (B)	
27-1	S12052000	2	ロックシリンダ"-	LOCK CYLINDER	
27-2	S11426000	4	エルボ"ユニオン4M5	ELBOW UNION 4M5	
28	S12053000	8	CQ2ボ"ルトM3X25	CQ2 BOLT M3X25	
29	028030243	8	ハ"ネサ"カ"ネ2-3	SPRING WASHER 2-3	
30	S12136009	1	アームR	ARM (R)	
31	S12137009	1	アームL	ARM (L)	
32	014060632	2	ア"ナトメ6X6クホ"ミ	SET SCREW 6X6	
33	S12135000	2	ロックシリンダ"-クミB	LOCK CYLINDER ASSEMBLY (B)	
33-1	S12052000	2	ロックシリンダ"-	LOCK CYLINDER	
33-2	S11426000	4	エルボ"ユニオン4M5	ELBOW UNION 4M5	
34	S12053000	8	CQ2ボ"ルトM3X25	CQ2 BOLT M3X25	
35	028030243	8	ハ"ネサ"カ"ネ2-3	SPRING WASHER 2-3	
36	S12138000	1	シリンダ"-25X50クミ	CYLINDER 25X50 ASSEMBLY	
36-1	S12140000	1	シリンダ"-25X50	CYLINDER 25X50	
36-2	S12139000	1	ヨ"ウト"ウウケカナク"1	ROCK SUPPORT METAL FITTING 1	
36-3	S11994000	1	2ヤマナツク"ルシ"ヨイント1	KNUCKLE JOINT 1	
36-4	S11426000	2	エルボ"ユニオン4M5	ELBOW UNION 4M5	
37	S12141000	1	シリンダ"-25X50Sクミ	CYLINDER 25X50 (S) ASSEMBLY	
37-1	S12142000	1	シリンダ"-25X50S	CYLINDER 25X50 (S)	
37-2	S12139000	1	ヨ"ウト"ウウケカナク"1	ROCK SUPPORT METAL FITTING 1	
37-3	S11994000	1	2ヤマナツク"ルシ"ヨイント1	KNUCKLE JOINT 1	
37-4	S11426000	2	エルボ"ユニオン4M5	ELBOW UNION 4M5	
38	S12271000	1	スイツチ"トリツケカナク"25	SWITCH SET METAL FITTING 25	
39	S12144100	1	シリンダ"-20X50クミ	CYLINDER 20X50 ASSEMBLY	
39-1	S12146000	1	シリンダ"-20X50	CYLINDER 20X50	
39-2	S12145000	1	ヨ"ウト"ウウケカナク"2	ROCK SUPPORT METAL FITTING 2	
39-3	S11988000	1	2ヤマナツク"ルシ"ヨイント2	KNUCKLE JOINT 2	
39-4	S15567000	2	スピ"コン(OUT)	SPEED CONTROLLER (OUT)	
40	S11880000	1	スイツチ"トリツケカナク"20	SWITCH SET METAL FITTING 20	
41	018501222	12	アナボ"ルト5X12	BOLT 5X12	
42	028050242	12	ハ"ネサ"カ"ネ2-5	SPRING WASHER 2-5	
43	S12148000	1	シリンダ"-20X330クミ	CYLINDER 20X330 ASSEMBLY	
43-1	S12149000	1	シリンダ"-20X330	CYLINDER 20X330	
43-2	S12150000	2	ホ"ースエルボ"M-5HL-4	TUBE ELBOW (M-5HL-4)	

T. 折曲ゲ土台関係 / Folding margin base mechanism / Faltungsvorrichtunggrundplatte /
 Mécanisme de base de marge d'ourlet / Mecanismo base de margen de plegado

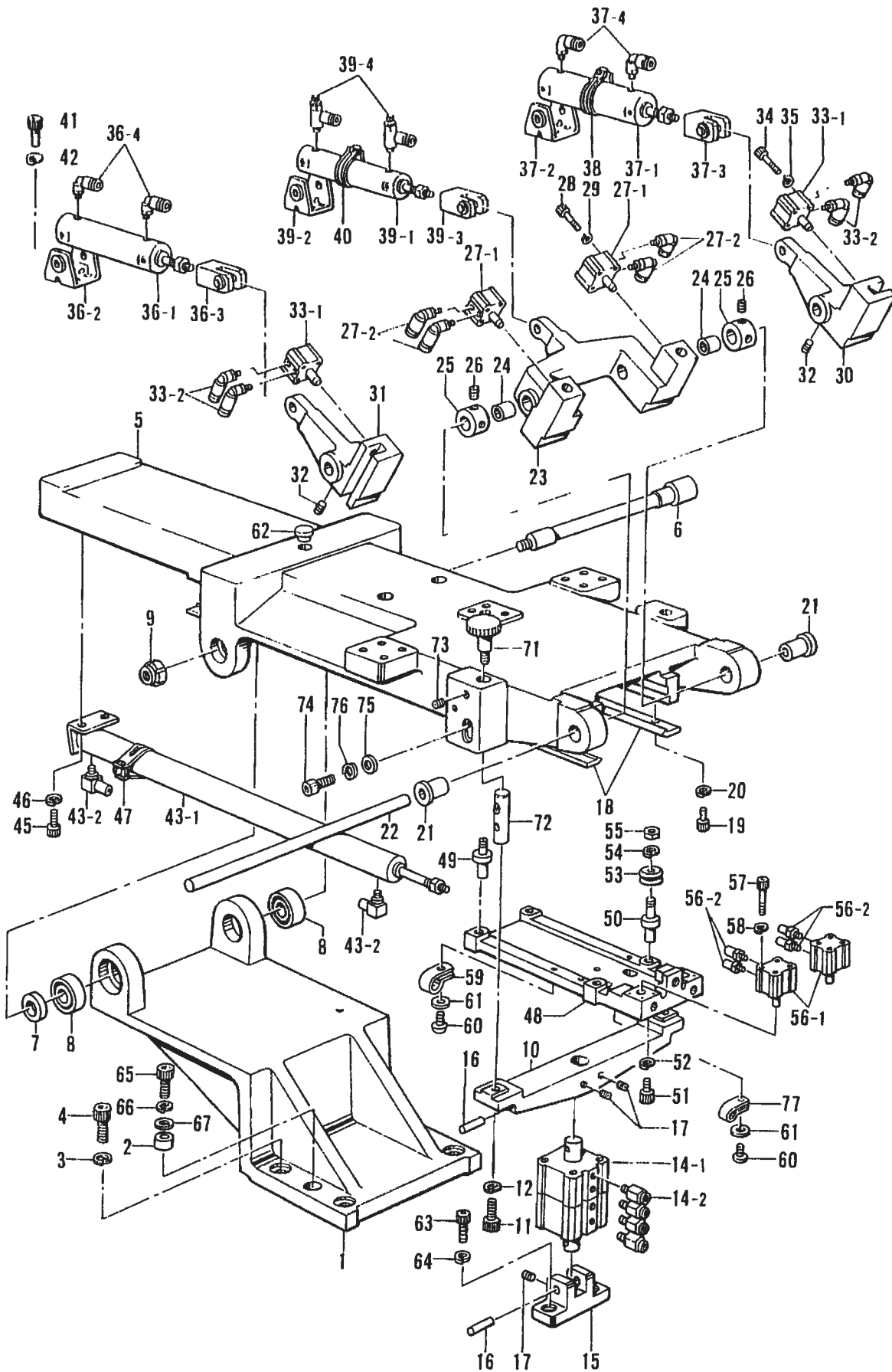

T. 折曲ゲ土台関係/Folding margin base mechanism/Faltungsvorrichtungsgfundplatte/
 Mécanisme de base de marge d'ourlet/Mecanismo base de margen de plegado

REI NO	CODE	Q'TY	ヒンメイ	NAME OF PARTS	RMKS
45	018501222	2	アナホ"ルト5X12	BOLT 5X12	
46	028050242	2	ハ"ネサ"カ"ネ2-5	SPRING WASHER 2 5	
47	S11880000	1	スイッチトリツケカナク"20	SWITCH SET METAL FITTING 20	
48	S12151009	1	ケ"ーシ"ササエ	CENTER BLADE SUPPORT	
49	S12152001	2	ケ"ーシ"ササエシ"クA	CENTER BLADE SUPPORT SHAFT (A)	
50	S12153001	2	ケ"ーシ"ササエシ"クB	CENTER BLADE SUPPORT SHAFT (B)	
51	018400822	4	アナホ"ルト4X8	BOLT 4X8	
52	028040242	4	ハ"ネサ"カ"ネ2-4	SPRING WASHER 2-4	
53	S12154000	4	カ"イト"ホイール	GUIDE WHEEL	
54	028040242	4	ハ"ネサ"カ"ネ2-4	SPRING WASHER 2-4	
55	021400103	4	ナツト1シユ4	NUT 4	
56	S12051000	2	ロックシリンダ"ークミA	LOCK CYLINDER ASSEMBLY (A)	
56 1	S12052000	2	ロックシリンダ"ー	LOCK CYLINDER	
56 2	S11433000	4	ホースニツプル4M5	HOSE NIPPLE 4M5	
57	S12053000	8	CQ2ホ"ルトM3X25	CQ2 BOLT M3X25	
58	028030243	8	ハ"ネサ"カ"ネ2-3	SPRING WASHER 2-3	
59	525664000	1	コート"ホルタ"6N	CORD HOLDER 6N	
60	062400806	4	ナヘ"コ4X8	SCREW 4X8	
61	025040233	4	ヒラサ"カ"ネチユウ4	PLAIN WASHER 4	
62	117934009	1	メクラセン	OIL CAP	
63	018062022	2	アナホ"ルト6X20	BOLT 6X20	
64	028060242	2	ハ"ネサ"カ"ネ2-6	SPRING WASHER 2-6	
65	018062522	2	アナホ"ルト6X25	BOLT 6X25	
66	028060242	2	ハ"ネサ"カ"ネ2-6	SPRING WASHER 2-6	
67	025060232	2	ヒラサ"カ"ネチユウ 6	PLAIN WASHER 6	
71	S15526001	2	アシ"ヤストネシ"	ADJUST SCREW	
72	S15525001	2	チヨウセイシ"ク	ADJUST SHAFT	
73	014060632	2	アナトメ6X6クホ"ミ	SET SCREW 6X6	
74	018062022	2	アナホ"ルト6X20	BOLT 6X20	
75	025060232	2	ヒラサ"カ"ネチユウ 6	PLAIN WASHER 6	
76	028060242	2	ハ"ネサ"カ"ネ2-6	SPRING WASHER 2-6	
77	S00480000	3	コート"ホルタ"5N	CORD HOLDER 5N	

U. 給油・潤滑関係(2)/Lubrication (2)/Schmierung (2)/
Lubrification (2)/Lubricación (2)

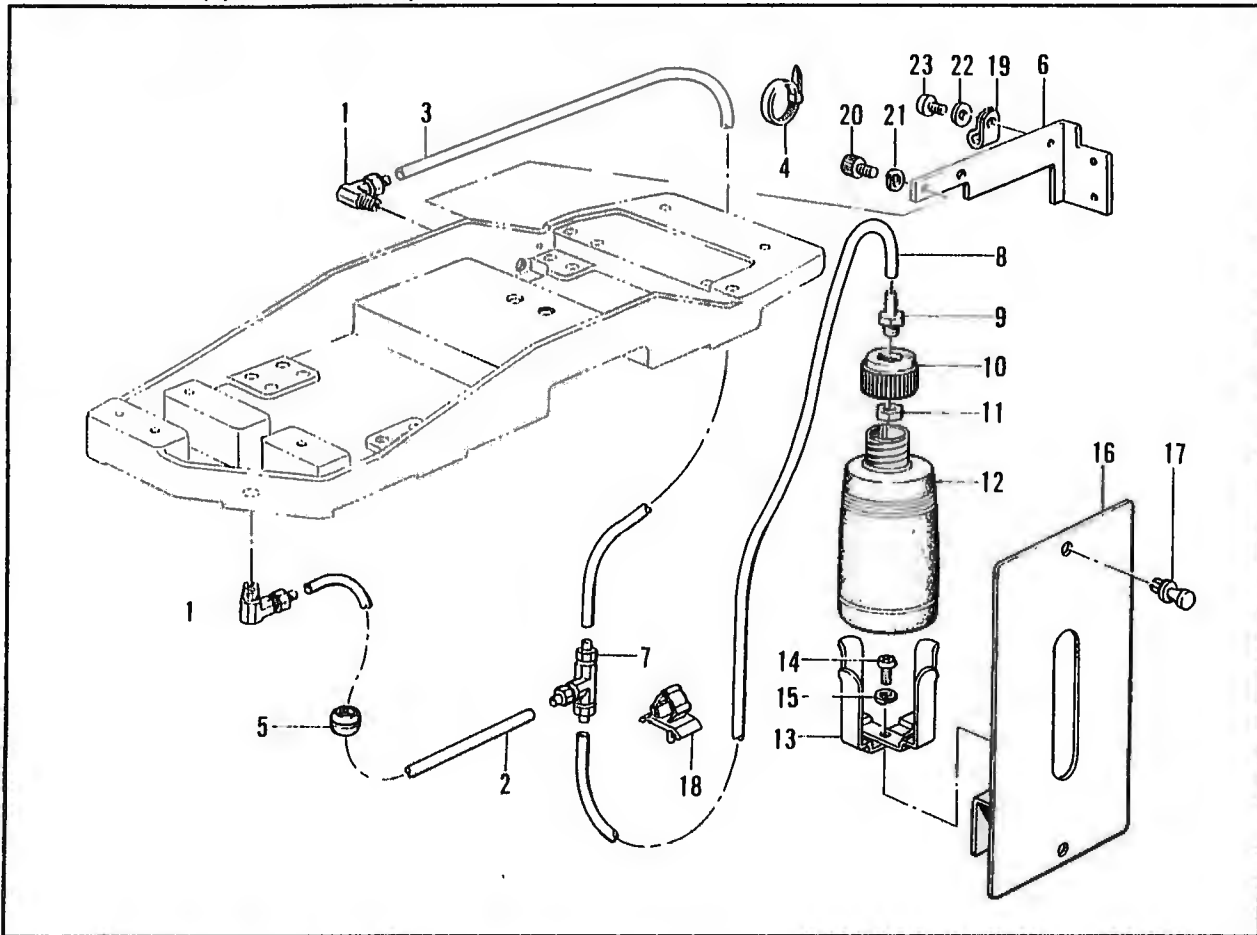

V. プリント基板関係/Printed circuit boards mechanism/Leiterplatten/
Circuits imprimés/Tableros de circuitos impresos

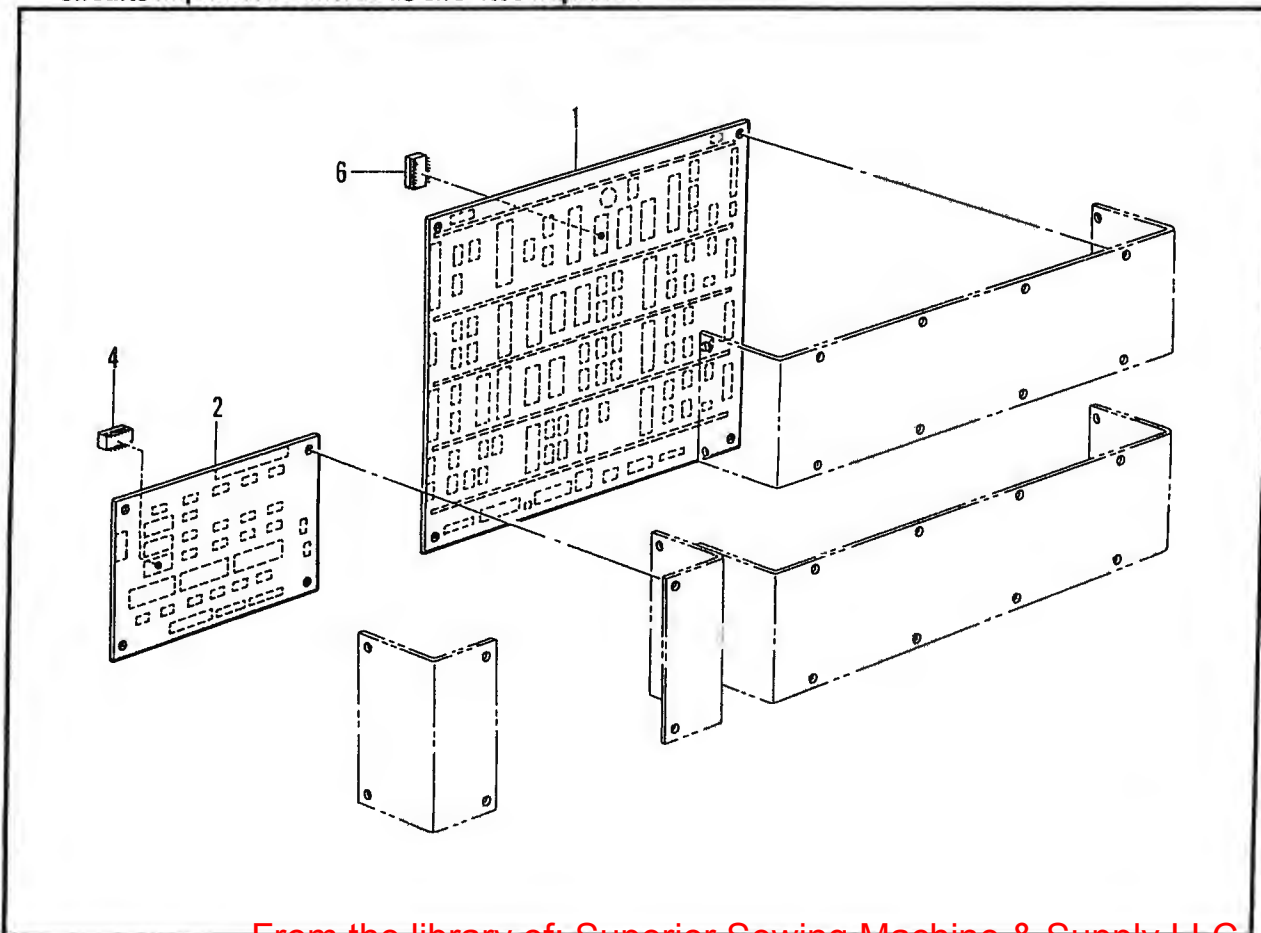

U. 給油・潤滑関係(2)/Lubrication (2)/Schmierung (2)/
Lubrification (2)/Lubricación (2)

REF NO	CODE	Q'TY	ヒンメイ	NAME OF PARTS	RMKS
1	S12043000	2	エルボ"ユニオン	ELBOW UNION	
2	S11946000	1	ビ"ニルチューブ"(L 1350)	OIL TUBE (L- 1350)	
3	S11947000	1	ビ"ニルチューブ"(L 800)	OIL TUBE (L- 800)	
4	S04159000	2	バンド"1M	BAND 1M	
5	S11949000	1	ゴムフ"ツシユ	RUBBER BUSH	
6	S19523001	1	チューブ"ササエ	TUBE SUPPORT	
7	S12483000	1	チース"ユニオン	T-UNION	
8	S12484000	1	ビ"ニルチューブ"(L 350)	OIL TUBE (L- 350)	
9	154468001	1	ハイユク"チ	OIL FEEDING	
10	144508001	1	ホ"リオイル"ノス"ルトメ	CAP	
11	106147002	1	ナツト7.94	NUT 7.94	
12	114486002	1	ホ"リオイル"タイ	OILER	
13	133172003	1	アフ"ラサシ"タイ	OIL BRACKET	
14	062401006	1	ナヘ"コ4X10	SCREW 4X10	
15	028040243	1	ハ"ネサ"カ"ネ2-4	SPRING WASHER 2-4	
16	S12482009	1	オイル"タイトリツケ"イタ	OILER SET PLATE	
17	S12481000	2	ナイラツチ	NYLATCH	
18	S11848000	1	コード"クランプ"7N	CORD CLAMP 7N	
19	149547000	1	コード"オサエ"4N	CORD HOLDER 4N	
20	018400832	2	アナボ"ルト4X8	BOLT 4X8	
21	028040242	2	ハ"ネサ"カ"ネ2-4	SPRING WASHER 2-4	
22	025040233	1	ヒラサ"カ"ネチユウ4	PLAIN WASHER 4	
23	062400806	1	ナヘ"コ4X8	SCREW 4X8	

V. プリント基板関係/Printed circuit boards mechanism/Leiterplatten/
Circuits imprimés/Tableros de circuitos impresos

REF.NO.	CODE	Q'TY	ヒンメイ	NAME OF PARTS	RMKS
1	S19513000	1	メインキハ"ンクミN	MAIN CIRCUIT BOARD ASSEMBLY (N)	
2	S11825000	1	オリキキハ"ンクミ	FOLDING MACHINE CIRCUIT BOARD ASSEMBLY	
6	S19518000	1	PROM751-1	PROM 751-1	
〈ワーキングシヨウナシ /FOR W/O WORKING〉					
4	S11837100	1	PROM750-2	PROM 750-2	

W. 糸巻関係/Bobbin winder mechanism/Spuler/
Mécánisme du bobineur/Mecanismo del devanador de la canilla

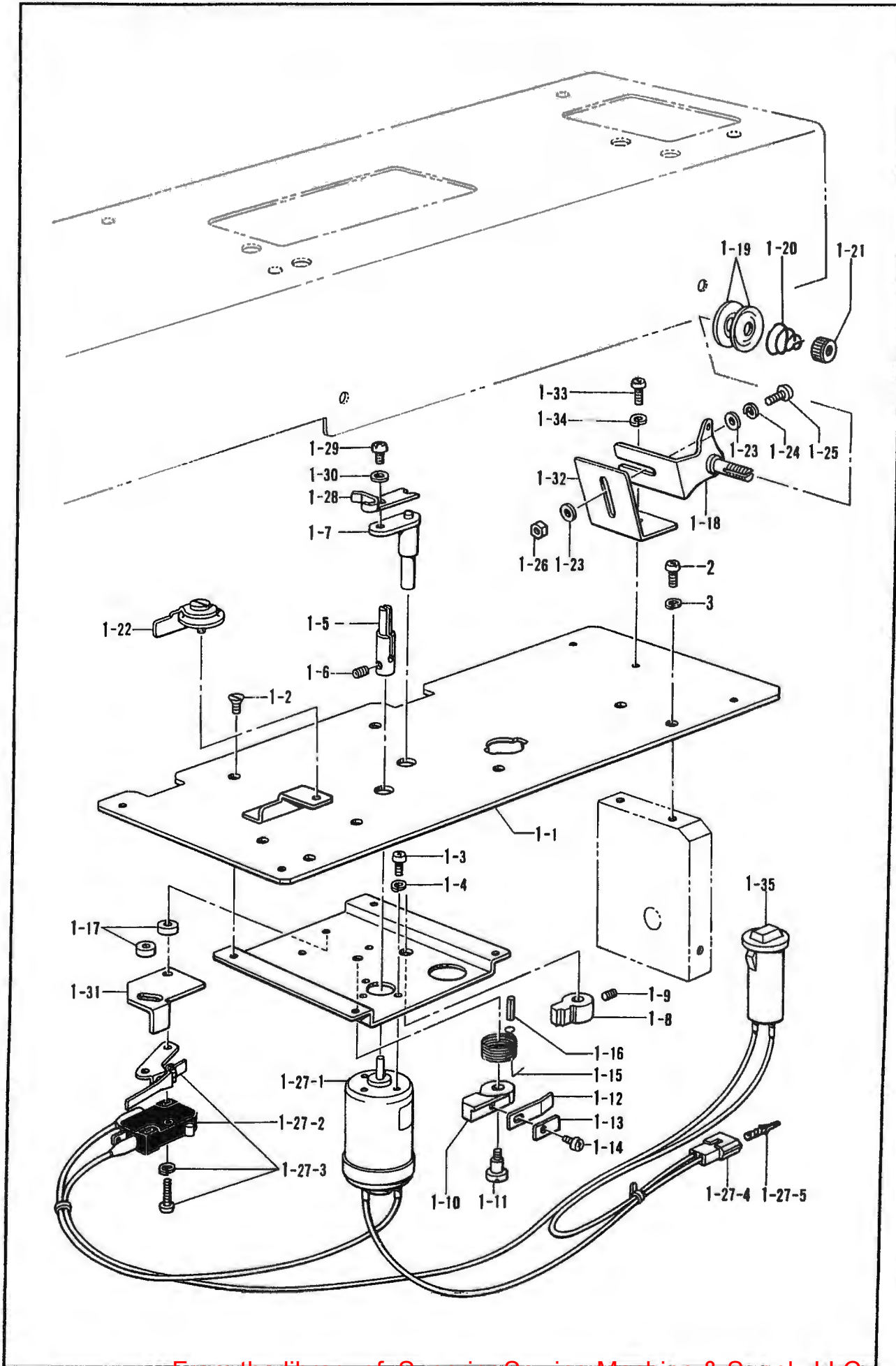

W. 糸巻関係/ Bobbin winder mechanism/ Spuler/
 Mécanisme du bobineur/ Mecanismo del devanador de la canilla

RII NO	CODI	Q'TY	ヒンメイ	NAME OF PARTS	RMKS
1	S17701009	1	イトマキソウチクミ	BOBBIN WINDER EQUIPMEINT ASSEMBLY	
1 1	S12027109	1	イトマキベース	BOBBIN WINDER BASE	
1 2	004300513	4	イサラネジ"3X5	SCREW 3X5	
1 3	062300605	3	ナヘ"コ3X6	SCREW 3X6	
1 4	028030242	3	ハ"ネサ"カ"ネ2-3	SPRING WASHER 2-3	
1 5	152358001	1	イトマキシ"ク	BOBBIN WINDER SHAFT	
1 6	014300332	2	アナクホ"ミ3X3	SET SCREW 3X3	
1 7	154024001	1	ホ"ヒ"ンオサエ	BOBBIN PRESSER	
1 8	154092001	1	イトマキツメタ"ンツキ	BOBBIN WINDER CLAW	
1 9	014680472	2	アナトメネジ"4.37クホ"ミ	SET SCREW 4.37	
1-10	152361001	1	イトマキレハ"ー	BOBBIN WINDER LEVER	
1 11	152362001	1	イトマキタ"ンネジ"	BOBBIN WINDER STUD SCREW	
1 12	111942001	1	イタハ"ネ	PLATE SPRING	
1 13	111943001	1	イタハ"ネサ"カ"ネ	PLATE SPRING WASHER	
1 14	060660512	1	ハ"イント"318-40X5	SCREW 318X5	
1 15	152363001	1	ネジ"リハ"ネA	TWIST SPRING (A)	
1 16	047301042	1	スフ"リンク"ヒ"ン	SPRING PIN	
1 17	152364001	2	カラ"ー	COLLAR	
1-18	145571101	1	イトマキアンナイダ"イクミ	BOBBIN WINDER GUIDE BRACKET ASSEMBLY	
1-19	145446001	2	イトチヨウシサラ	TENSION DISC	
1 20	100401001	1	イトチヨウシハ"ネ	TENSION SPRING	
1-21	100136001	1	イトチヨウシナツト	TENSION NUT	
1-22	146197001	1	イトツカミクミ	THREAD CLAMP ASSEMBLY	
1-23	025040232	2	ヒラサ"カ"ネチユウ4	PLAIN WASHER 4	
1-24	028040242	1	ハ"ネサ"カ"ネ2-4	SPRING WASHER 2 4	
1-25	062401012	1	ナヘ"コM4X10	SCREW M4X10	
1-26	021400202	1	2シユナツト4	NUT 4	
1-27	S19522001	1	イトマキモータクミ	BOBBIN WINDER MOTOR ASSEMBLY	
1-27-1	S16667000	1	イトマキモータ	BOBBIN WINDER MOTOR	
1-27-2	152507000	1	マイクロスイッチD	MICRO SWITCH (D)	
1-27-3	152508000	1	マイクロアクチエータ	MICRO ACTUATOR	
1-27-4	152509000	1	ナイロンコネクタE	NYLON CONNECTOR (E)	
1-27-5	552851001	2	ピンターミナル#1854	TERMINAL PIN #1854	
1-28	152645001	1	ホ"ヒ"ンオサエイタ	BOBBIN HOLD PLATE	
1-29	062300616	1	ナヘ"コ M3X6	SCREW M3X6	
1-30	025030233	1	ヒラサ"カ"ネチユウ3	PLAIN WASHER 3	
1-31	158597001	1	イトマキストツハ"ー	BOBBIN WINDER STOPPER	
1-32	158598009	1	イトマキアンナイトリツケイタ	BOBBIN WINDER GUIDE SET PLATE	
1-33	062401012	1	ナヘ"コM4X10	SCREW M4X10	
1-34	028040242	1	ハ"ネサ"カ"ネ2-4	SPRING WASHER 2-4	
1-35	S16669000	1	プロテクタ0.5A	PROTECTOR 0.5A	
2	062400806	4	ナヘ"コ4X8	SCREW 4X8	
3	028040243	4	ハ"ネサ"カ"ネ2-4	SPRING WASHER 2-4	

X. 空圧関係 / Air pressure mechanism / Luftdruck /
 Mécanisme de la pression d'air / Mecanismo de la presión de aire

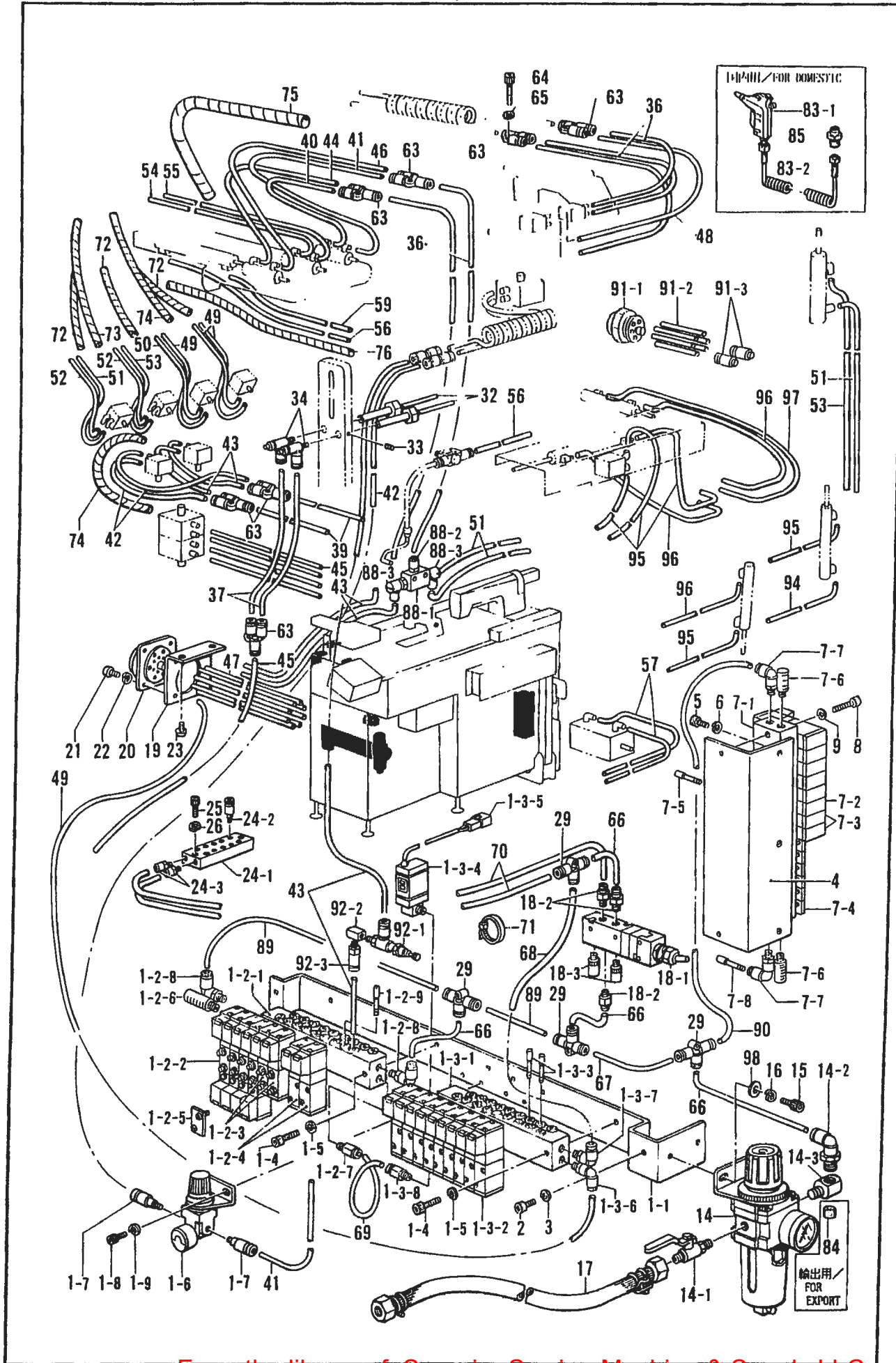

エエ圧機/Air pressure mechanism/Luftdruck/
Mécánisme de la pression d'air/Mecanismo de la presión de aire

REF NO	CODE	Q'TY	ヒンメイ	NAME OF PARTS	RMKS
1	S19559001	1	ハ"ルフ"クミ2レツ	VALVE ASSEMBLY (DOUBLE ROW)	
1 1	S12155101	1	ハ"ルフ"トリツクイタ	VALVE SET PLATE	
1-2	S17730001	1	ハ"ルフ"9ヒタ"リクミ	VALVE 9 LEFT ASSEMBLY	
1-2-1	S19067000	1	マニホルト"9	MANIHOLD 9	
1 2-2	S12158000	4	ハ"ルフ"VZ3243-N	VALVE VZ3243-N	
1 2-3	S12160000	2	ハ"ルフ"VZ3143-N	VALVE VZ3143-N	
1-2-4	S12161000	2	ハ"ルフ"VZ3143	VALVE VZ3143	
1 2 5	S12159001	1	メクラフタクミ	OIL CAP	
1-2 6	140682001	1	サイレンサー	SILENCER	
1 2-7	S01522000	1	ハーフユニオン	HALF UNION	
1-2 8	S01542000	2	エルボ"ユニオン61	ELBOW UNION 61	
1 2 9	S04897000	1	メクラセン	BLIND CAP	
1-3	S17729000	1	ハ"ルフ"9ミキ"クミ	VALVE 9 RIGHT ASSEMBLY	
1-3-1	S19067000	1	マニホルト"9	MANIHOLD 9	
1-3-2	S12161000	9	ハ"ルフ"VZ3143	VALVE VZ3143	
1-3-3	S04897000	2	メクラセン	BLIND CAP	
1-3-4	S12164000	1	アツリヨクスイッチ	PRESSURE SWITCH	
1-3-5	152509000	1	ナイロンコネクタE	NYLON CONNECTOR (E)	
1 3-6	S04909000	1	エルボ"ユニオン	ELBOW UNION	
1-3-7	S01542000	1	エルボ"ユニオン61	ELBOW UNION 61	
1-3-8	S01522000	1	ハーフユニオン	HALF UNION	
1-4	018503022	4	アナホ"ルト5X30	BOLT 5X30	
1-5	028050242	4	ハ"ネサ"カ"ネ2-5	SPRING WASHER 2-5	
1-6	S12165000	1	レキ"ユレーター	REGULATOR	
1-7	S04905000	2	ハーフユニオン	HALF UNION	
1-8	018400832	2	アナホ"ルト4X8	BOLT 4X8	
1-9	028040242	2	ハ"ネサ"カ"ネ2-4	SPRING WASHER 2-4	
2	018060822	2	アナホ"ルト6X8	BOLT 6X8	
3	028060242	2	ハ"ネサ"カ"ネ2-6	SPRING WASHER 2-6	
4	S17723001	1	ハ"ルフ"トリツクイタミキ"	VALVE SET PLATE (RIGHT)	
5	018400832	3	アナホ"ルト4X8	BOLT 4X8	
6	028040242	3	ハ"ネサ"カ"ネ2-4	SPRING WASHER 2-4	
7	*	1	ハ"ルフ"14クミ	VALVE 14 ASSEMBLY	
7-1	S12157000	1	マニホルト"14	MANIFOLD 14	
7-2	S12160000	6	ハ"ルフ"VZ3143-N	VALVE VZ3143-N	
7-3	S12161000	2	ハ"ルフ"VZ3143	VALVE VZ3143	
7-4	S12159000	6	メクラフタクミ	BLIND PLATE ASSEMBLY	
7-5	S04897000	1	メクラセン	BLIND CAP	
7-6	140682001	1	サイレンサー	SILENCER	
7-7	S01542000	2	エルボ"ユニオン61	ELBOW UNION 61	
7-8	S04577000	1	メクラセン	BLIND CAP	
8	018503022	2	アナホ"ルト5X30	BOLT 5X30	
9	028050242	2	ハ"ネサ"カ"ネ2-5	SPRING WASHER 2-5	
14	S12166000	1	フィルタ"レキ"ユレータークミ	FILTER REGULATOR ASSEMBLY	
14-1	S09231000	1	ホ"ールハ"ルフ"1/4	BALL VALVE 1/4	
14-2	S04896000	1	エルボ"ユニオン	ELBOW UNION	
14-3	153252000	1	PTチース"	PT-JOINT	
15	018061422	2	アナホ"ルト6X14	BOLT 6X14	
16	028060242	2	ハ"ネサ"カ"ネ2-6	SPRING WASHER 2-6	
17	149796001	1	ゴ"ムホースカナク"ツキ	AIR TUBE WITH CONNECTOR	
18	S12168000	1	メカニカルハ"ルフ"クミ	MECHANICAL VALVE ASSEMBLY	
18-1	S12169000	1	メカニカルハ"ルフ"	MECHANICAL VALVE	
18-2	S01522000	3	ハーフユニオン	HALF UNION	
18-3	S12170000	2	サイレンサ	SILENCER	
19	S12171001	1	カクヘキイター1	BULKHEAD PLATE	
20	S12172000	1	マルチコネクタS	MULTI CONNECTOR (S)	
21	062400812	4	ナヘ"コ4X8	SCREW 4X8	
22	028040242	4	ハ"ネサ"カ"ネ2-4	SPRING WASHER 2-4	
23	062680812	2	ナヘ"コ437-40X8	SCREW 437X8	

X. 空圧関係 / Air pressure mechanism / Luftdruck /
 Mécanisme de la pression d'air / Mecanismo de la presión de aire

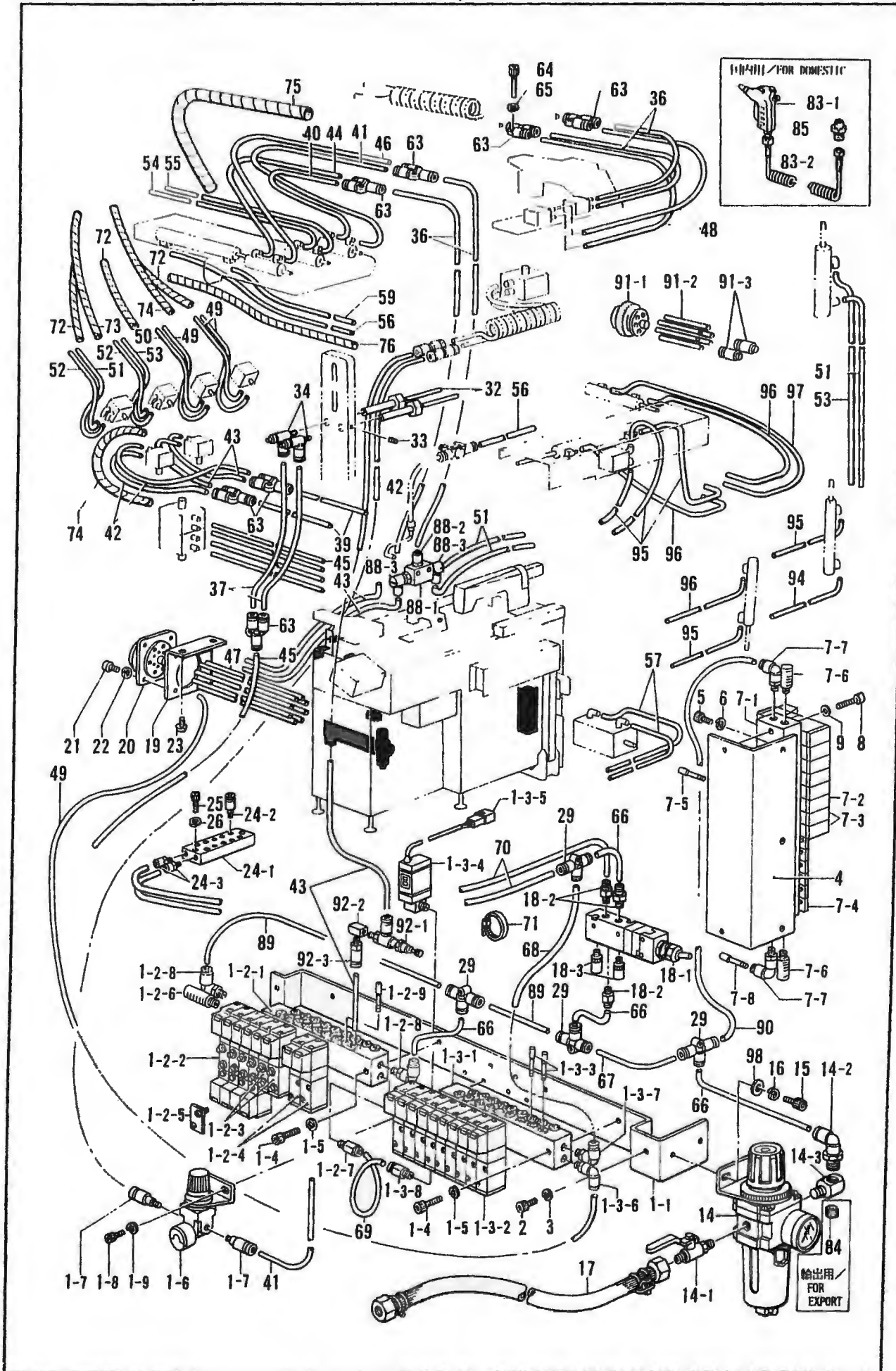

X. 空気関係/Air pressure mechanism/Luftdruck/
Mécánisme de la pression d'air/Mecanismo de la presión de aire

REF NO	CODE	Q'TY	品名	NAME OF PARTS	RMKS
24	S12167000	1	マニホルト"12クミ	MANIFOLD 12 ASSEMBLY	
24 1	S12173000	1	マニホルト"	MANIFOLD	
24 2	S04905000	12	ハーフユニオン	HALF UNION	
24 3	S12174000	2	ホースニツアル6M5	HOSE NIPPLE 6M5	
25	018401622	2	アナホルト4X16	BOLT 4X16	
26	028040242	2	ハ"ネサ"カ"ネ2-4	SPRING WASHER 2-4	
29	S12175000	4	チース"06	T-JOINT 06	
32	S12176000	2	エアブ"ロワー	AIR BLOWER	
33	014400522	2	アナクホ"ミ4X5	SET SCREW 4X5	
34	S14328000	2	シホ"ツハ"ン	THROTTLE VALVE	
36	S12178000	4	エア-ホース4X2.5-2	AIR TUBE 4X2.5-2 (L=130)	
37	S12179000	2	エア-ホース4X2.5-3	AIR TUBE 4X2.5-3 (L=190)	
39	S12181000	2	エア-ホース4X2.5-5	AIR TUBE 4X2.5-5 (L=290)	
40	S12182000	7	エア-ホース4X2.5-6	AIR TUBE 4X2.5-6 (L=340)	
41	S12183000	2	エア-ホース4X2.5-7	AIR TUBE 4X2.5-7 (L=430)	
42	S12184000	3	エア-ホース4X2.5-8	AIR TUBE 4X2.5-8 (L=480)	
43	S12185000	5	エア-ホース4X2.5-9	AIR TUBE 4X2.5-9 (L=510)	
44	S12186000	1	エア-ホース4X2.5-10	AIR TUBE 4X2.5-10 (L=520)	
45	S12187000	5	エア-ホース4X2.5-11	AIR TUBE 4X2.5-11 (L=570)	
46	S12188000	1	エア-ホース4X2.5-12	AIR TUBE 4X2.5-12 (L=600)	
47	S12189000	8	エア-ホース4X2.5-13	AIR TUBE 4X2.5-13 (L=630)	
48	S12190000	2	エア-ホース4X2.5-14	AIR TUBE 4X2.5-14 (L=310)	
49	S12191000	4	エア-ホース4X2.5-15	AIR TUBE 4X2.5-15 (L=770)	
50	S12192000	1	エア-ホース4X2.5-16	AIR TUBE 4X2.5-16 (L=780)	
51	S12193000	4	エア-ホース4X2.5-17	AIR TUBE 4X2.5-17 (L=890)	
52	S12194000	2	エア-ホース4X2.5-18	AIR TUBE 4X2.5-18 (L=920)	
53	S12195000	2	エア-ホース4X2.5-19	AIR TUBE 4X2.5-19 (L=930)	
54	S12196000	1	エア-ホース4X2.5-20	AIR TUBE 4X2.5-20 (L=1060)	
55	S12197000	1	エア-ホース4X2.5-21	AIR TUBE 4X2.5-21 (L=1090)	
56	S12198000	2	エア-ホース4X2.5-22	AIR TUBE 4X2.5-22 (L=1300)	
57	*	2	エア-ホース4X2.5-15	AIR TUBE 4X2.5-15 (L=770)	
59	S12201000	1	エア-ホース4X2.5-25	AIR TUBE 4X2.5-25 (L=1700)	
63	S12104000	7	ユニオンワイ4	UNION-Y 4	
64	018403022	3	アナホルト4X30	BOLT 4X30	
65	028040242	3	ハ"ネサ"カ"ネ2-4	SPRING WASHER 2-4	
66	S12206000	4	エア-ホース6X4-1	AIR TUBE 6X4-1 (L=50)	
67	S12207000	1	エア-ホース6X4-2	AIR TUBE 6X4-2 (L=170)	
68	S12208000	1	エア-ホース6X4-3	AIR TUBE 6X4-3 (L=200)	
69	S12209000	1	エア-ホース6X4-4	AIR TUBE 6X4-4 (L=320)	
70	S12210000	2	エア-ホース6X4-5	AIR TUBE 6X4-5 (L=400)	
71	S04159000	25	バンド"1M	BAND 1M	
72	S12211000	3	スパイラル130S	SPIRAL 130S	
73	S12212000	1	スパイラル290S	SPIRAL 290S	
74	S12213000	2	スパイラル430S	SPIRAL 430S	
75	S12214000	1	スパイラル640L	SPIRAL 640L	
76	S12215000	1	スパイラル640S	SPIRAL 640S	
84	140542001	1	-----	1/4PT CAP	
88	S15561000	2	クイックエキゾ"ー"ストクミ	QUICK EXHAUST ASSEMBLY	
88-1	S15562000	2	クイックエキゾ"ー"スト	QUICK EXHAUST	
88-2	S11433000	2	ホースニツアル4M5	HOSE NIPPLE 4M5	
88-3	S12150000	4	ホースエルボ"M-5HL-4	TUBE ELBOW (M-5HL-4)	
89	S19585000	2	エア-ホース6X4-6	AIR TUBE 6X4-6 (L=230)	
90	S19586000	1	エア-ホース6X4-7	AIR TUBE 6X4-7 (L=1200)	
91	S19554000	1	マルチコネクター6Pクミ	MULTI CONNECTOR (6P) ASSEMBLY	
91-1	S19549000	1	マルチコネクター6P	MULTI CONNECTOR (6P)	
91-2	S19556000	6	エア-ホース4X2.5-50	AIR TUBE 4X2.5-50	
91-3	S19555000	6	キャツプ4	CAP 4	
92	S19971000	1	ゲ"ン"アツハ"ンM5-04クミ	REDUCING VALVE M5-04 ASSEMBLY	
92-1	S19972000	1	ゲ"ン"アツハ"ンM5-04	REDUCING VALVE M5-04	
92-2	S19973000	1	エルボ"M-5L	ELBOW M-5L	
92-3	S04905000	1	ハーフユニオン	HALF UNION	
94	*	1	エア-ホース4X2.5-15	AIR TUBE 4X2.5-15 (L=770)	

X. 空圧関係/Air pressure mechanism/Luftdruck/
 Mécanisme de la pression d'air/Mecanismo de la presión de aire

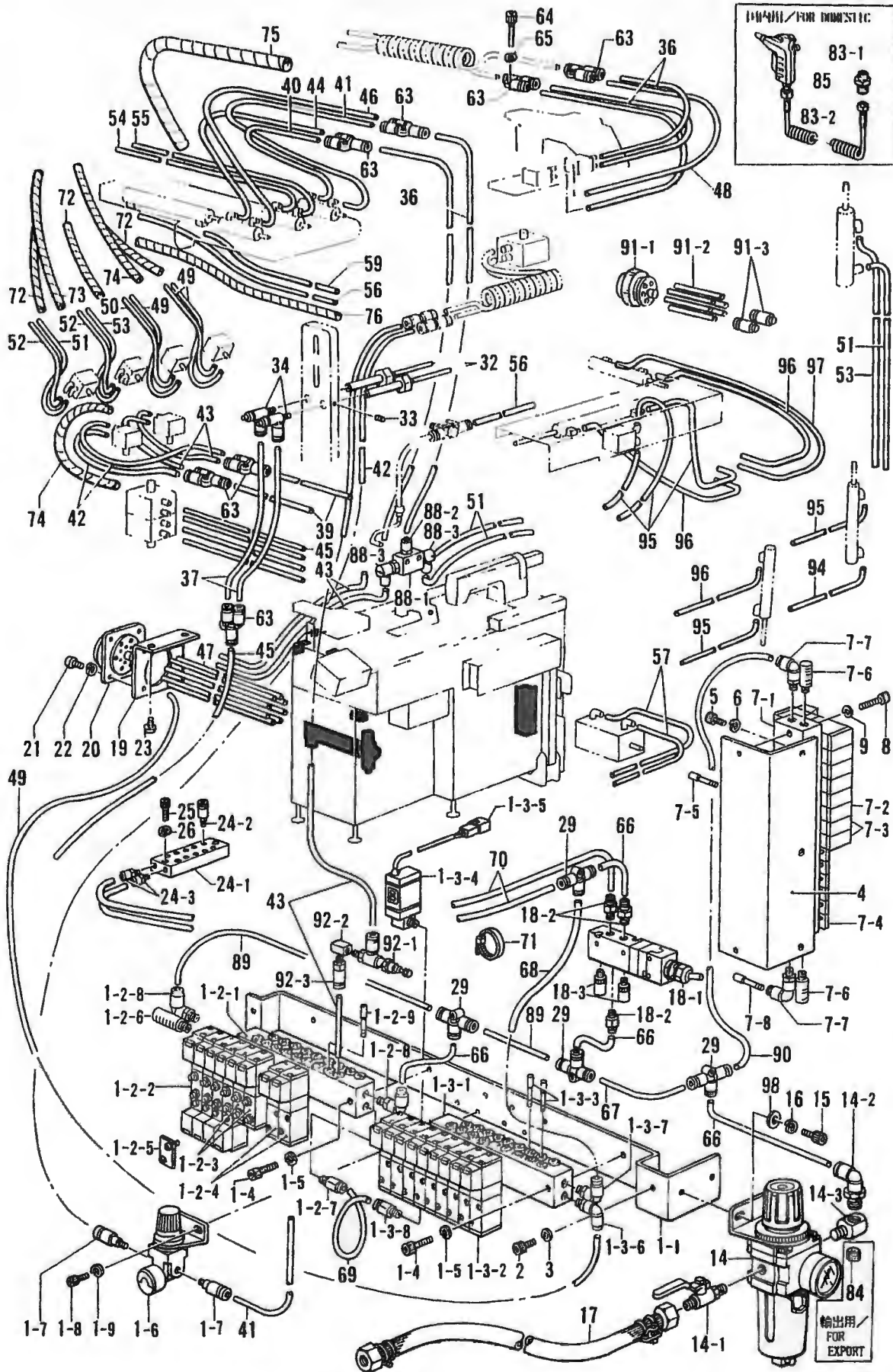

X. 空圧関係/Air pressure mechanism/Luftdruck/
Mécánisme de la pression d'air/Mecanismo de la presión de aire

RF+ NO	CODE	Q'TY	品名	NAME OF PARTS	RMKS
95	*	6	エアホース4X2.5-17	AIR TUBE 4X2.5-17 (L .890)	
96	*	3	エアホース4X2.5-20	AIR TUBE 4X2.5 20 (L 1060)	
97	*	1	エアホース4X2.5-21	AIR TUBE 4X2.5-21 (L 1090)	
98	025060232	2	ヒラサ"カ"ネチユ6	PLAIN WASHER 6	
(コクナイヨウ オプション)					
83	S06857000	1	エアガンクミ	-----	
83 1	S06858000	1	エアガン	-----	
83 2	S06859000	1	カールホース	-----	
85	S04891000	1	チユウカンニツアル1/4	-----	

X. 空圧関係 / Air pressure mechanism / Luftdruck /
 Mécanisme de la pression d'air / Mecanismo de la presión de aire

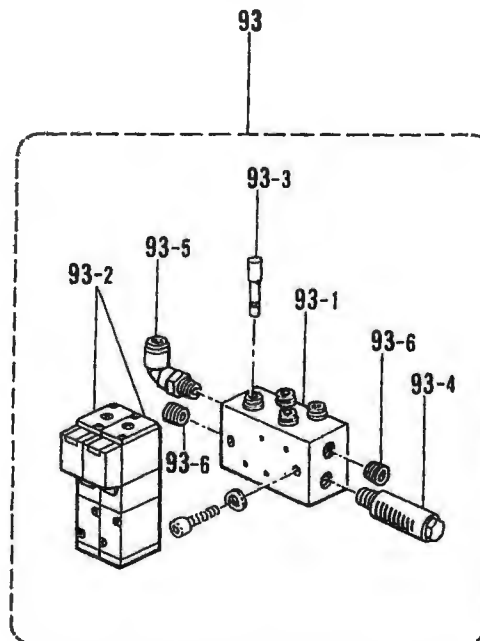
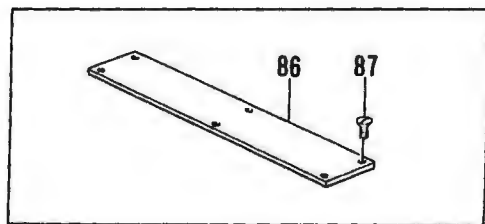
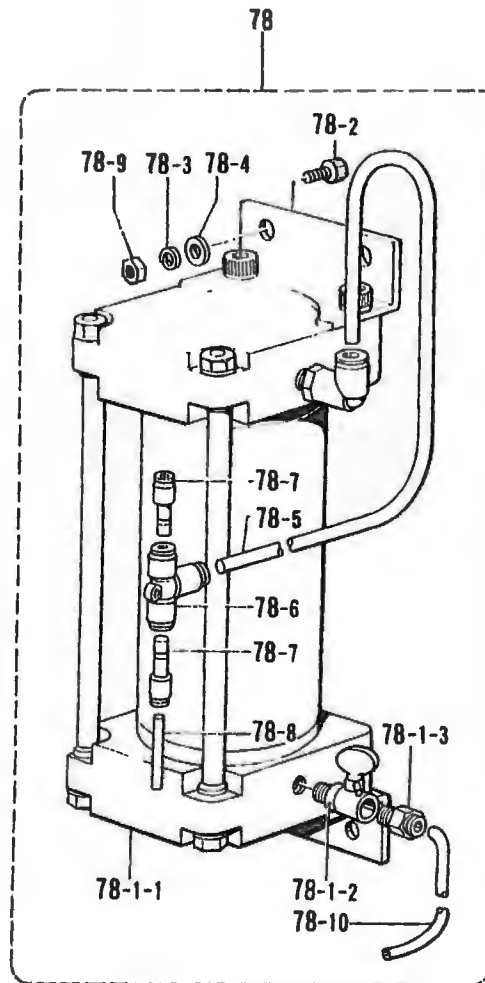
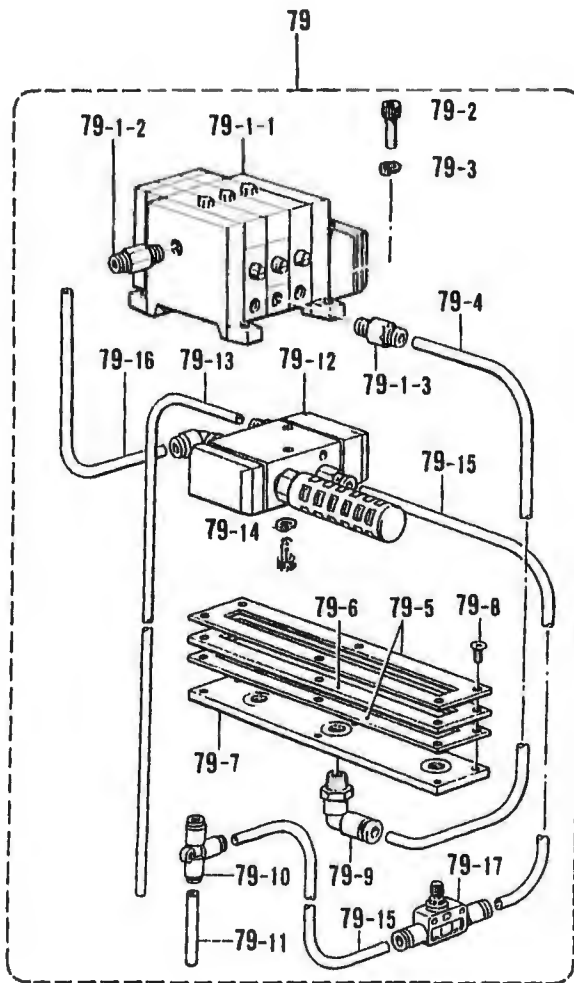

X. 空圧関係/Air pressure mechanism/Luftdruck/
Mécánisme de la pression d'air/Mecanismo de la presión de aire

RLI NO	CODE	Q'TY	ヒンメイ	NAME OF PARTS	RMKS
78	S12495001	1	-----	TANK UNIT	
78 1	S11953000	1	-----	AIR TANK ASSEMBLY	
78 1 1	S11952000	1	-----	AIR TANK	
78 1 2	149438000	1	-----	SPEED CONTROLLER (B)	
78 1 3	S01522000	1	-----	HALF UNION	
78 2	018081622	2	-----	BOLT 8X16	
78 3	028080242	2	-----	SPRING WASHER 2-8	
78 4	025080232	2	-----	PLAIN WASHER 8	
78 5	S11956000	1	-----	AIR TUBE 10X75 (L 1700)	
78 6	S11957000	1	-----	T JOINT 010	
78 7	S11958000	2	-----	REDUCER	
78 8	S12206000	1	-----	AIR TUBE 6X4-1 (L 50)	
78 9	021080302	2	-----	NUT 8	
78 10	S12207000	1	-----	AIR TUBE 6X4-2 (L-170)	
79	*	1	ハ"キユームソウチクミ	VACUUM EQUIPMENT ASSEMBLY	
79 1	S12497000	1	シンクウエシ"エクタークミ	VACUUM EJECTOR ASSEMBLY	
79 1 1	S12498000	1	シンクウエシ"エクター	VACUUM EJECTOR	
79 1 2	S01208000	1	ハーフユニオン	HALF UNION	
79 1 3	S01522000	3	ハーフユニオン	HALF UNION	
79-2	018501622	2	アナボ"ルト5X16	BOLT 5X16	
79 3	028050242	2	ハ"ネサ"カ"ネ2-5	SPRING WASHER 2-5	
79-4	S12209000	2	エア-ホ-ス6X4-4	AIR TUBE 6X4-4 (L=320)	
79-5	S12499000	2	ハ"キユームガ"スケツト	VACUUM GASKET	
79-6	S12500001	1	ハ"キユームウエ	VACUUM UPPER	
79 7	S12501001	1	ハ"キユームシタ	VACUUM LOWER	
79-8	004401414	6	+サラネシ"4X14	SCREW 4X14	
79-9	S04896000	3	エルボ"ユニオン	ELBOW UNION	
79-10	S12175000	1	チ-ス"06	T-JOINT 06	
79-11	S12206000	1	エア-ホ-ス6X4-1	AIR TUBE 6X4-1 (L=50)	
79-12	S12502000	1	エアオヘ"ハ"ルプ"クミ	AIR OPERATION VALVE ASSEMBLY	
79-13	S12191000	1	エア-ホ-ス4X2.5-15	AIR TUBE 4X2.5-15 (L=770)	
79-14	028030242	2	ハ"ネサ"カ"ネ2-3	SPRING WASHER 2-3	
79-15	S12207000	2	エア-ホ-ス6X4-2	AIR TUBE 6X4-2 (L=170)	
79 16	S12210000	2	エア-ホ-ス6X4-5	AIR TUBE 6X4-5 (L=400)	
79-17	S12509000	1	シボ"リハ"ン6	THROTTLE VALVE6	
86	*	1	ハ"キユームウラフタ	-----	
87	*	6	サラネシ"4.37	-----	
93	*	1	ハ"ルプ"2クミ	-----	
93-1	S19676000	1	マニホルト"2	-----	
93-2	S12161000	2	ハ"ルプ"VZ3143	-----	
93-3	S04897000	1	メクラセン	-----	
93-4	140682001	1	サイレンサー	-----	
93-5	S01542000	1	エルボ"ユニオン61	-----	
93-6	153274001	2	1/8トメセン	-----	

Y. 電装品関係(2)/Power supply equipment mechanism (2)/Stromversorgung (2)/
 Mécanisme de l'équipement en alimentation électrique (2)/
 Mecanismo del equipo de alimentación de corriente (2)

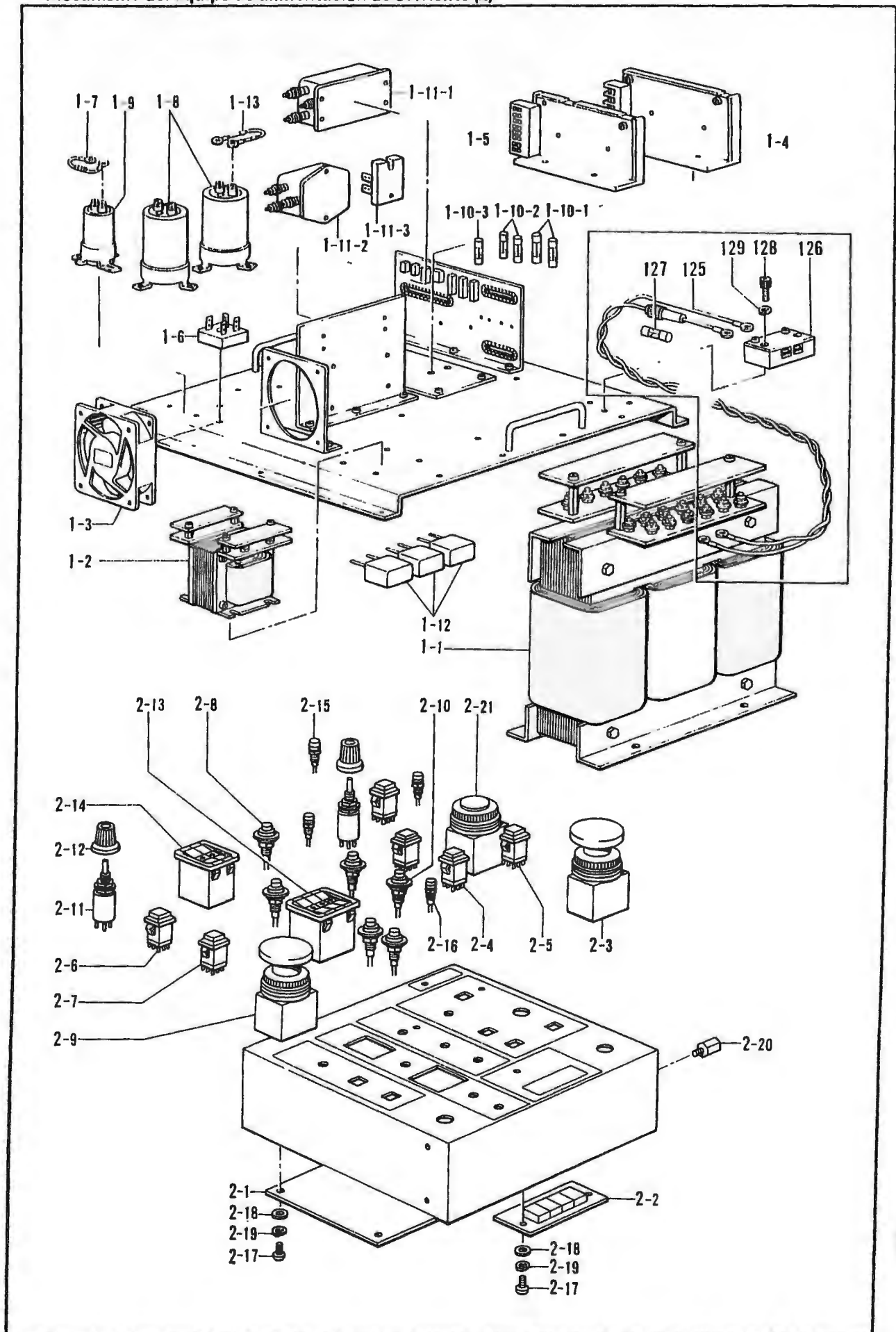

Y. 電機品関係(2)/Power supply equipment mechanism (2)/Stromversorgung (2)/
 Mécanisme de l'équipement en alimentation électrique (2)/
 Mecanismo del equipo de alimentación de corriente (2)

RII NO	CODE	Q'TY	ヒンメイ	NAME OF PARTS	RMKS
1	S11823101	1	デ"ンゲ"ンソウチクミ	POWER SUPPLY EQUIPMENT ASSEMBLY	
1 1	S11806000	1	3ソウトランス	3-PHASE TRANSFORMER	
1 2	S11807000	1	タンソウトランス	1-PHASE TRANSFORMER	
1 3	S05068000	1	クーリング"ファン	COOLING FAN	
1 4	S11813000	1	AVR-1	AVR-1	
1-5	S11814000	1	AVR-2	AVR-2	
1-6	S11835000	1	セイリユウフ"リツシ"	RECTIFIER BRIDGE	
1 7	S11783000	1	フ"リーター"テイコウクミ	BLEEDER RESISTOR ASSEMBLY	
1-8	S11809000	2	ハイカツコンテ"ンサB	ELECTROLYTIC CAPACITOR (B)	
1 9	S11808000	1	ハイカツコンテ"ンサA	ELECTROLYTIC CAPACITOR (A)	
1-10 1	S11734000	2	フューズ"20A	FUSE (20A)	
1-10 2	152565000	2	ヒューズ"B	FUSE (B)	
1-10 3	S11705000	1	スローフ"ローヒューズ"	SLOW BLOW FUSE	
1 11 1	S11811000	1	ノイズ"フィルタA	NOISE FILTER (A)	
1 11 2	S11812000	1	ノイズ"フィルタB	NOISE FILTER (B)	
1-11 3	S11810000	1	3ソウフ"リツシ"	3-PHASE BRIDGE	
1-12	S11815000	3	クロスラインコンテ"ンサ	CROSS LINE CAPACITOR	
1-13	S11798000	1	LEDチエツククミ	LIGHT EMITTING DIODE CHECK ASSEMBLY	
2	S19520109	1	751 ソウサBOXクミ	OPERATION BOX ASSEMBLY (751)	
2-1	S11826000	1	ヒョウシ"キハ"ンクミ	INDICATE CIRCUIT BOARD ASSEMBLY	
2-2	S11827000	1	LEDキハ"ンクミ	LIGHT EMITTING DIODE ASSEMBLY	
2-3	S11756100	1	スイッチ1M	SWITCH 1M	
2-4	S11755000	1	スイッチ2M	SWITCH 2M	
2-5	S11754000	2	スイッチ3M	SWITCH 3M	
2-6	S11753000	2	スイッチ4M	SWITCH 4M	
2-7	S11752000	1	スイッチ5A	SWITCH 5A	
2-8	S11749000	5	スイッチ6M	SWITCH 6M	
2-9	S11750000	1	スイッチ7M	SWITCH 7M	
2-10	S11751000	1	スイッチ8M	SWITCH 8M	
2-11	S11748000	2	ロータリスイッチ	ROTARY SWITCH	
2-12	157875000	2	ロータリスイッチツマミ	ROTARY SWITCH KNOB	
2-13	S11757000	1	デ"ジ"タルSW3	DIGITAL SWITCH (3)	
2-14	S04993000	1	デ"ジ"タルスイッチB	DIGITAL SWITCH (B)	
2-15	152430000	3	LED-B	LIGHT EMITTING DIODE (B)	
2-16	152429000	1	LED-A	LIGHT EMITTING DIODE (A)	
2-17	002300803	6	+ナハ"ネシ"3X8	SCREW 3X8	
2-18	025030133	6	ヒラサ"カ"ネシヨウ3	PLAIN WASHER 3	
2-19	028030243	6	ハ"ネサ"カ"ネ2-3	SPRING WASHER 2-3	
2-20	S11761000	1	アースタンシ	EARTH TERMINAL	
2-21	S11706000	1	スイッチ9M	SWITCH 9M	
125	*	1	-----	LIGHT HARNESS	
126	*	1	-----	TERMINAL BLOCK 2P	
127	*	1	-----	FUSE 0.5A	
128	*	2	-----	BOLT 4X12	
129	*	2	-----	SPRING WASHER 2-4	

Y. 電装品関係(2)/Power supply equipment mechanism (2)/Stromversorgung (2)/
Mécánisme de l'équipement en alimentation électrique (2)/
Mecanismo del equipo de alimentación de corriente (2)

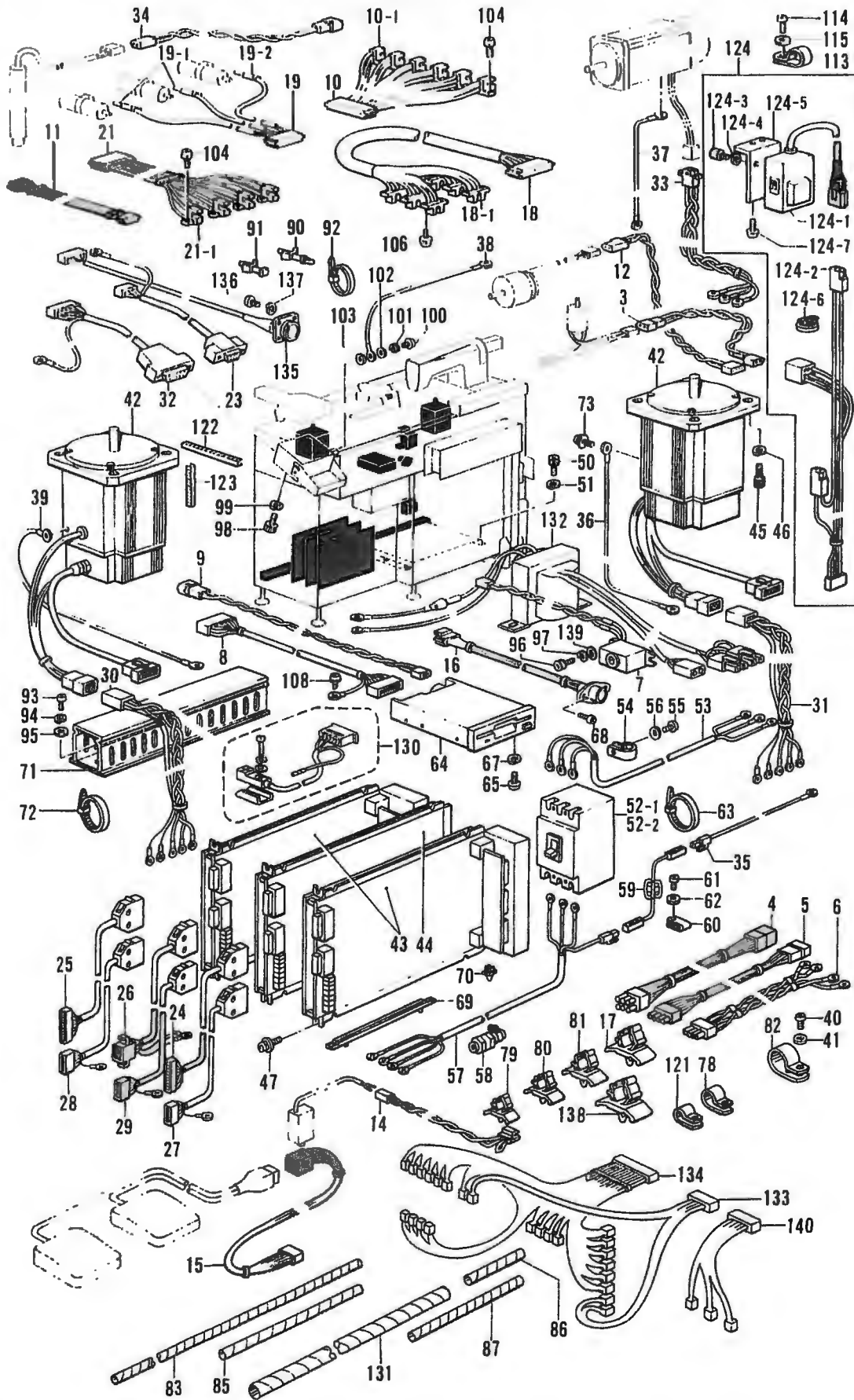

Power supply equipment mechanism (2)/Stromversorgung (2)/
 Mécanisme de l'équipement en alimentation électrique (2)/
 Mecanismo del equipo de alimentación de corriente (2)

RII NO.	CODE	Q'TY	ヒンメイ	NAME OF PARTS	RMKS
3	S11702000	1	イトマキハーネス	BOBBIN WINDER HARNESS	
4	S11688100	1	デ"ンケ"ンハーネスA	POWER SUPPLY HARNESS (A)	
5	S11689000	1	デ"ンケ"ンハーネスB	POWER SUPPLY HARNESS (B)	
6	S11690000	3	デ"ンケ"ンハーネスC	POWER SUPPLY HARNESS (C)	
7	S11693000	1	ブ"サ"ークミ	BUZZER ASSEMBLY	
8	S11694000	1	FDDハーネス	FDD HARNESS	
9	S11695000	1	FDDデ"ンケ"ンハーネス	FDD POWER SUPPLY HARNESS	
10	S11696000	1	フォトセンサクミ	PHOTO SENSOR ASSEMBLY	
10 1	S08119000	6	ホトセンサーEE-SV3	PHOTO SENSOR EE-SV3	
11	S11697000	1	オリキハーネス	FOLDING MACHINE HARNESS	
12	S11698000	1	イトキリハーネス	THREAD TRIMMER HARNESS	
14	S11703000	1	エアSWハーネス	AIR SWITCH HARNESS	
15	*	1	フットSWハーネス	FOOT SWITCH HARNESS	
16	S11701000	1	プ"ログ"ラマハーネス	PROGRAMMER HARNESS	
17	S09141000	10	コート"クランプ"16-L	CORD CLAMP 16-L	
18	S11715100	1	ジ"ク"ハ"ター"ンクミ	JIG PATTERN ASSEMBLY	
18-1	S05035000	6	フォトマイクロセンサ	PHOTO MICRO SENSOR	
19	S11712000	1	シリンダ"センサクミ	CYLINDER SENSOR ASSEMBLY	
19-1	S12458000	2	シリンダ"センサ2	CYLINDER SENSOR-2	
19-2	S12459000	1	シリンダ"センサ3	CYLINDER SENSOR-3	
21	S11711000	1	クランプ"イン"センサクミ	CLAMP-IN SENSOR ASSEMBLY	
21 1	S08119000	4	ホトセンサーEE-SV3	PHOTO SENSOR EE-SV3	
23	S11716000	1	オリキソウサホ"ツクス"ハーネス	FOLDING MACHINE OPERATION BOX HARNESS	
24	S11718000	1	エンコータ"ハーネスX	ENCODER HARNESS (X)	
25	S11719000	1	エンコータ"ハーネスY	ENCODER HARNESS (Y)	
26	S11720000	1	エンコータ"ハーネスZ	ENCODER HARNESS (Z)	
27	S11721000	1	サーボ"ハーネスX	SERVO HARNESS (X)	
28	S11722000	1	サーボ"ハーネスY	SERVO HARNESS (Y)	
29	S11723000	1	サーボ"ハーネスZ	SERVO HARNESS (Z)	
30	S11724000	1	モータ"ハ"ウ"ハーネスX	MOTOR POWER HARNESS (X)	
31	S11725000	1	モータ"ハ"ウ"ハーネスY	MOTOR POWER HARNESS (Y)	
32	S11717000	1	ソウサBOXハーネス	OPERATION BOX HARNESS	
33	S11726000	1	モータ"ハ"ウ"ハーネスZ	MOTOR POWER HARNESS (Z)	
34	S11727000	1	マーカハーネス	MARKER HARNESS	
35	S11729000	1	アースインダ"クタ2	EARTH INDUCTOR (2)	
36	S11730000	2	アースセン700	EARTH WIRE (700)	
37	S11731000	3	アースセン1300	EARTH WIRE 1300	
38	S11732000	4	アースセン1700S	EARTH WIRE 1700S	
39	S11733000	1	アースセン1700	EARTH WIRE 1700	
40	062400806	10	ナヘ"コ4X8	SCREW 4X8	
41	025040233	10	ヒラサ"ガ"ネチユウ4	PLAIN WASHER 4	
42	S11738100	2	クト"ウ"モータクミ	DRIVING MOTOR ASSEMBLY	
43	S11740000	2	400Wト"ライハ"	400W DRIVER	
44	S11739000	1	200Wト"ライハ"	200W DRIVER	
45	018082022	8	アナホ"ルト8X20	BOLT 8X20	
46	028080242	8	ハ"ネサ"ガ"ネ2-8	SPRING WASHER 2-8	
47	052400806	6	ナヘ"コハ"ネヒラ4X8	WASHER SCREW 4X8	
50	018400822	6	アナホ"ルト4X8	BOLT 4X8	
51	028040242	6	ハ"ネサ"ガ"ネ2-4	SPRING WASHER 2-4	
52-1	*	1	-----	NO FUSE BREAKER (5A)	
52-2	*	1	ノーヒューズ"フ"レー"カーB	NO FUSE BREAKER (B)	
53	S11691000	1	デ"ンケ"ンハーネスD	POWER SUPPLY HARNESS (D)	
54	554482000	1	コート"ホルダ"12N	CORD HOLDER 12N	
55	062400806	1	ナヘ"コ4X8	SCREW 4X8	
56	025040233	1	ヒラサ"ガ"ネチユウ4	PLAIN WASHER 4	
57	S11692000	1	デ"ンケ"ンハーネスE	POWER SUPPLY HARNESS (E)	
58	152510000	1	コート"ブ"ツシユ	CORD BUSH	
59	S11728000	1	アースインダ"クタ1	EARTH INDUCTOR (1)	
60	S11816000	2	クランプ"NK-2N	CLAMP NK-2N	
61	062400806	2	ナヘ"コ4X8	SCREW 4X8	
62	025040233	2	ヒラサ"ガ"ネチユウ4	PLAIN WASHER 4	
63	S06143000	1	ハ"ンタイPLT4S	BAND PLT4S	

Y. 電装品関係(2)/Power supply equipment mechanism (2)/Stromversorgung (2)/
Mécanisme de l'équipement en alimentation électrique (2)/
Mecanismo del equipo de alimentación de corriente (2)

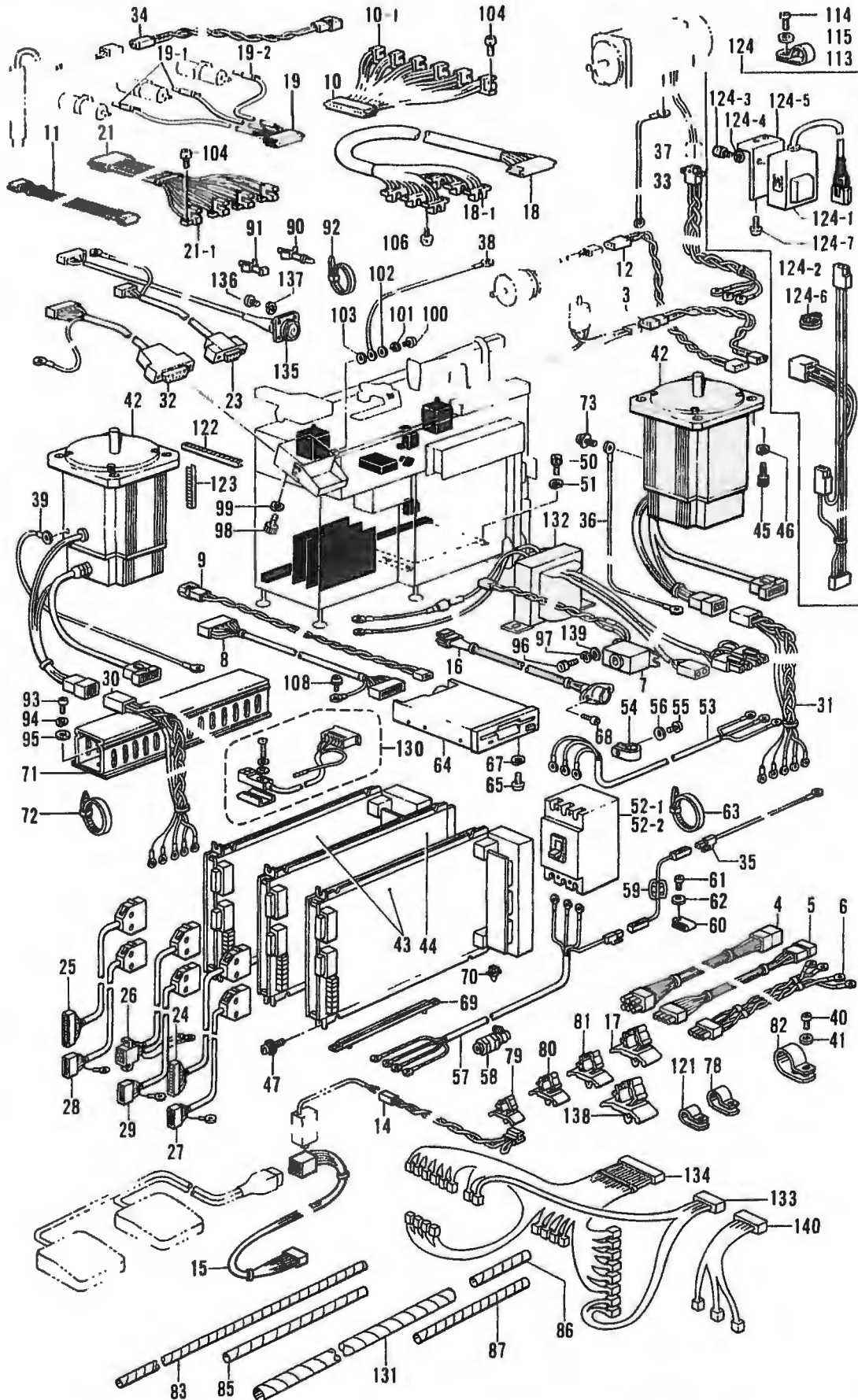

Y. 電装品関係(2)/Power supply equipment mechanism (2)/Stromversorgung (2)/
 Mécanisme de l'équipement en alimentation électrique (2)/
 Mecanismo del equipo de alimentación de corriente (2)

RLI NO	CODI	QTY	ヒンメイ	NAME OF PARTS	RMKS
64	S16661001	1	3.5フロッピー"ドライブ"	3.5 INCH FLOPPY DRIVE	
65	062300805	4	ナヘ"コ3X8	SCREW 3X14	
67	028030243	4	ハ"ネサ"カ"ネ2-3	SPRING WASHER 2-3	
68	062300505	2	ナヘ"コ3X5	SCREW 3X5	
69	S11840000	6	ガイド"レール	GUIDE RAIL	
70	S11841000	6	キハ"ンコ"テイ"ダ"イ	CIRCUIT BOARD FIXID STUD	
71	S11842000	1	ケー"ブル"ダ"クト	CABLE DUCT	
72	149809000	3	タイ"ラ"ツ"フ"ル	BEAD BAND (L)	
73	S18658001	2	ナヘ"コ"ハ"ネ"ヒ"ラ"4X6	WASHER SCREW 4X6	
78	525907000	4	コー"ト"ホル"タ"9N	CORD HOLDER 9N	
79	S11848000	8	コー"ト"ク"ラ"ン"フ"7N	CORD CLAMP 7N	
80	150349001	2	コー"ト"ク"ラ"ン"フ"10N	CORD CLAMP 10N	
81	150357001	3	コー"ト"ク"ラ"ン"フ"13-L	CORD CLAMP 13-L	
82	S11817000	4	ク"ラ"ン"フ"NK-18N	CLAMP NK-18N	
83	S12215000	1	ス"パ"イ"ラ"ル"640S	SPIRAL 640S	
85	S11764000	1	ス"パ"イ"ラ"ル"250S	SPIRAL 250S	
86	S11763000	2	ス"パ"イ"ラ"ル"100S	SPIRAL 100S	
87	S11762000	1	ス"パ"イ"ラ"ル"200S	SPIRAL 200S	
90	S02915000	8	キハ"ン"サ"ホ"ー"ト	CIRCUIT BOARD SUPPORT	
91	S11839000	14	キハ"ン"ス"ヘ"ー"サ	CIRCUIT BOARD SPACER	
92	S04159000	10	バ"ン"ド"1M	BAND 1M	
93	062401006	2	ナヘ"コ4X10	SCREW 4X10	
94	028040243	2	ハ"ネ"サ"カ"ネ"2-4	SPRING WASHER 2-4	
95	025040233	2	ヒ"ラ"サ"カ"ネ"チ"ユ"4	PLAIN WASHER 4	
96	018400822	2	ア"ナ"ホ"ル"ト"4X8	BOLT 4X8	
97	028040242	2	ハ"ネ"サ"カ"ネ"2-4	SPRING WASHER 2-4	
98	018400832	4	ア"ナ"ホ"ル"ト"4X8	BOLT 4X8	
99	028040242	4	ハ"ネ"サ"カ"ネ"2-4	SPRING WASHER 2-4	
100	062300506	1	ナヘ"コ3X5	SCREW 3X5	
101	028030243	1	ハ"ネ"サ"カ"ネ"2-3	SPRING WASHER 2-3	
102	025030133	1	ヒ"ラ"サ"カ"ネ"シ"ヨ"ウ"3	PLAIN WASHER 3	
103	025030233	1	ヒ"ラ"サ"カ"ネ"チ"ユ"3	PLAIN WASHER 3	
104	215083001	20	ナ"ナ"ヘ"セ"ツ"ト"3X6D	WASHER SCREW 3X6D	
106	215083001	12	ナ"ナ"ヘ"セ"ツ"ト"3X6D	WASHER SCREW 3X6D	
108	215083001	1	ナ"ナ"ヘ"セ"ツ"ト"3X6D	WASHER SCREW 3X6D	
113	552908000	2	コー"ト"ホル"タ"14N	CORD HOLDER 14N	
114	062400806	2	ナヘ"コ4X8	SCREW 4X8	
115	025040233	2	ヒ"ラ"サ"カ"ネ"チ"ユ"4	PLAIN WASHER 4	
121	149547000	1	コー"ト"オ"サ"エ"4N	CORD HOLDER 4N	
122	S04488000	1	シ"サ"イ"フ"ツ"シ"ユ"A	FREE BUSH (A)	
123	S12466000	1	シ"サ"イ"フ"ツ"シ"ユ"B	FREE BUSH (B)	
124	*	1	-----	HAND SWITCH ASSEMBLY	
124-1	S12565001	2	-----	HAND SWITCH (A) ASSEMBLY	
124-2	S12465000	1	-----	FOOT SWITCH HARNESS 2	
124-3	018400832	4	-----	BOLT 4X8	
124-4	028040242	4	-----	SPRING WASHER 2-4	
124-5	S11951001	1	-----	SWITCH SET PLATE	
124-6	S04159000	5	-----	BAND 1M	
124-7	062681012	2	-----	SCREW 437X10	
130	S12468000	1	オ"サ"エ"セ"ン"サ	SEWING CLAMP SENSOR	
131	S16452000	1	ス"パ"イ"ラ"ル"450L	SPIRAL 450L	
132	S16666000	1	マ"ー"カ"ー"ト"ラ"ン"ス"ク"ミ	MARKER TRANSFORMER ASSEMBLY	
133	S19509000	1	オ"サ"エ"ア"シ"ハ"ー"ネ"ス"N	WORK CLAMP HARNESS (N)	
134	S19510000	1	ソ"レ"ノ"イ"ド"ク"ト"ウ"ハ"ー"ネ"ス"N	SOLENOID DRIVING HARNESS (N)	
135	S19511000	1	2レ"ツ"ヨ"ウ"ハ"ー"ネ"ス	DOUBLE ROW HARNESS	
136	062300606	4	ナヘ"コ3X6	SCREW 3X6	
137	028030243	4	ハ"ネ"サ"カ"ネ"2-3	SPRING WASHER 2-3	
138	S09142000	1	コー"ト"ク"ラ"ン"フ"20-L	CORD CLAMP 20-L	
139	025040232	2	ヒ"ラ"サ"カ"ネ"チ"ユ"4	PLAIN WASHER 4	
140	S19508000	1	2レ"ツ"ハ"ル"フ"ハ"ー"ネ"ス	DOUBLE SEAM VALVE HARNESS	

A1. マーカー関係 / Marker mechanism / Markierungsvorrichtung /
 Mécanisme du marqueur / Mecanismo del marcador

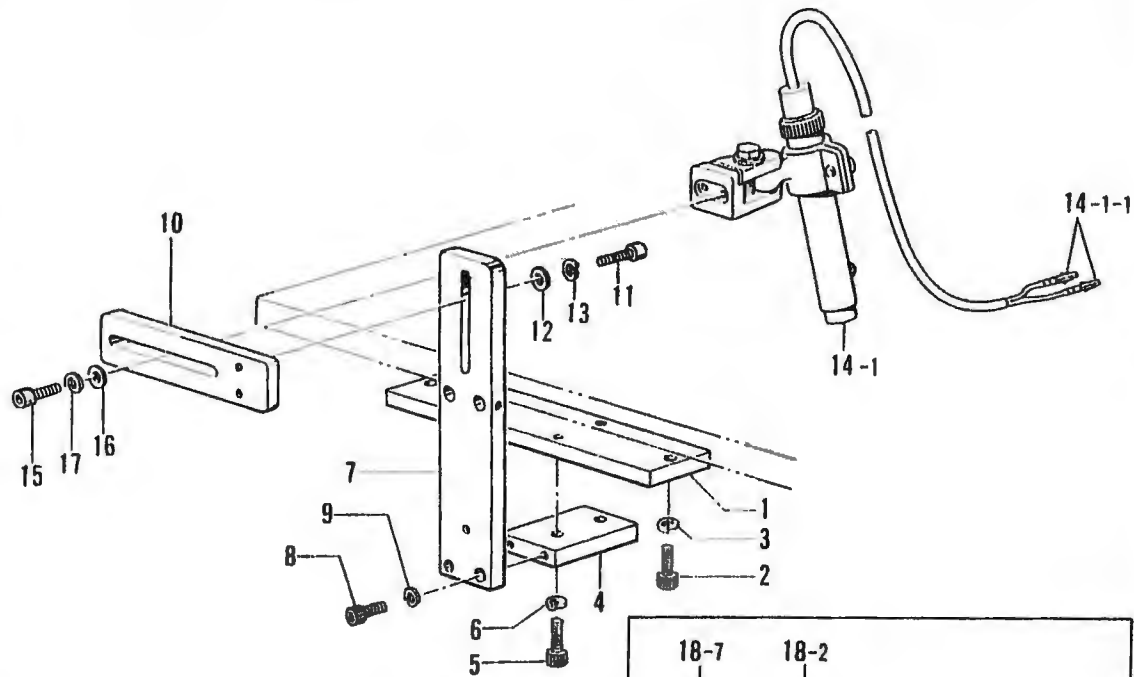

オプションパーツ / OPTION PARTS

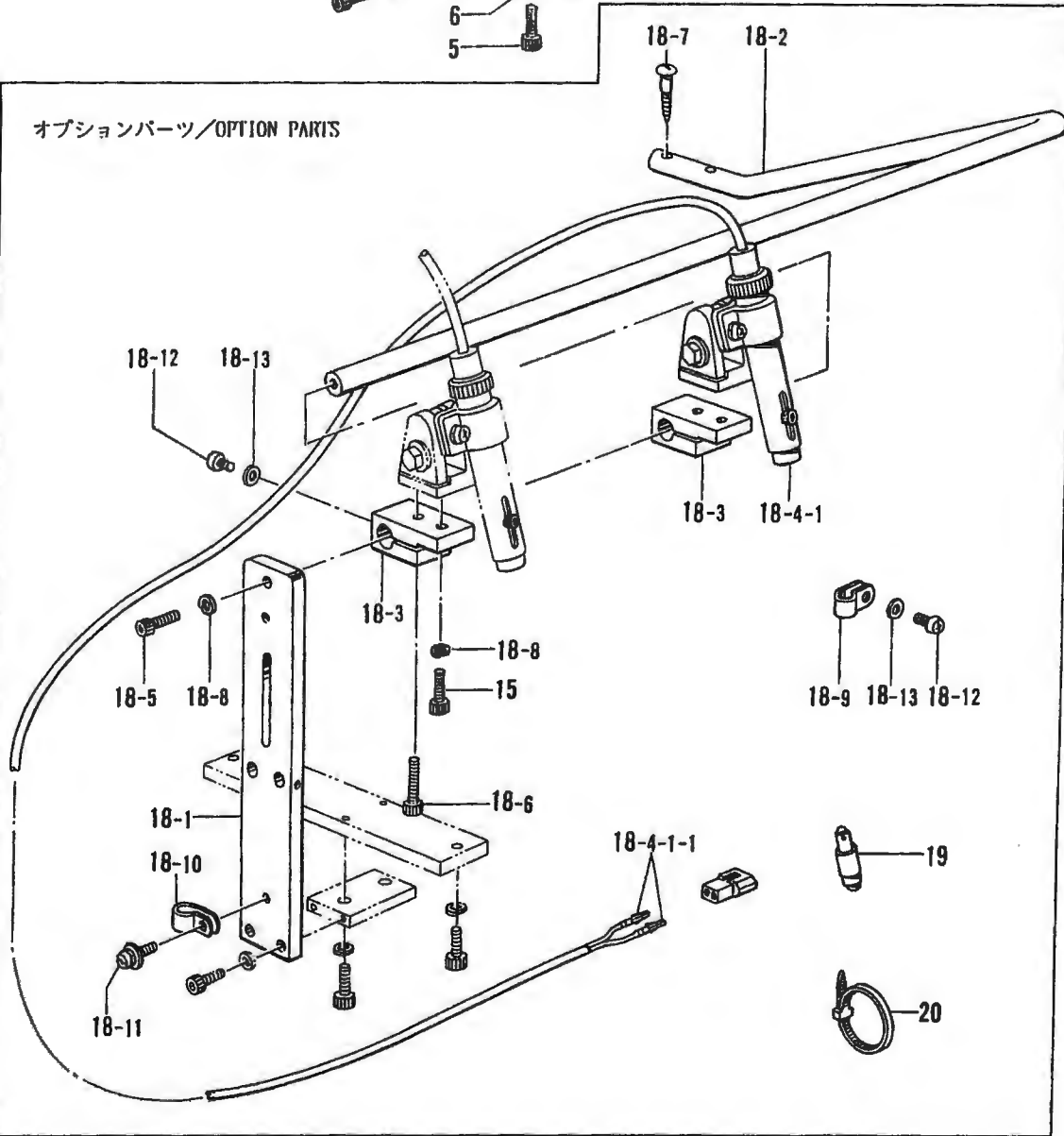

Mécanisme du marqueur / Mecanismo del marcador

RLI NO	CODE	QTY	ヒンメイ	NAME OF PARTS	RMKS
1	S12216001	1	ト"タ"イスヘ"サー	BASE SPACER	
2	018501622	2	アナホ"ルト5X16	BOLT 5X16	
3	028050242	2	ハ"ネサ"カ"ネ2-5	SPRING WASHER 2-5	
4	S12217001	1	ランフト"リツケ"タ"イ	LAMP SET STUD	
5	018502022	2	アナホ"ルト5X20	BOLT 5X20	
6	028050242	2	ハ"ネサ"カ"ネ2-5	SPRING WASHER 2-5	
7	S15569001	1	ランフト"タ"イ"サエ	LAMP BASE SUPPORT	
8	018501622	2	アナホ"ルト5X16	BOLT 5X16	
9	028050242	2	ハ"ネサ"カ"ネ2-5	SPRING WASHER 2-5	
10	S12219001	1	ランフト"タ"イ	LAMP BASE	
11	018502022	2	アナホ"ルト5X20	BOLT 5X20	
12	025050232	2	ヒラサ"カ"ネチユウ-5	PLAIN WASHER 5	
13	028050242	2	ハ"ネサ"カ"ネ2-5	SPRING WASHER 2-5	
14	S14488000	1	マーキング"ライト"クミ	MARKING LIGHT ASSEMBLY	
14 1	S08367000	1	ライト"マーカ	MARKING LIGHT	
14 1 1	S08017000	2	オスピン5006TL	PIN	
15	018502022	2	アナホ"ルト5X20	BOLT 5X20	
16	025050232	2	ヒラサ"カ"ネチユウ-5	PLAIN WASHER 5	
17	028050242	2	ハ"ネサ"カ"ネ2-5	SPRING WASHER 2-5	
〈オプション / OPTION PARTS〉					
18	S14487001	1	タ"フル"マーカ"クミ	DOUBLE MARKER ASSEMBLY	
18-1	S17710001	1	ランフト"タ"イ"サエL	LAMP BASE SUPPORT (L)	
18-2	S17711101	1	ランフト"リツケ	LAMP SETTER	
18-3	S17709001	2	マーカ"トリツケ	MARKER SETTER	
18-4	S14488000	1	マーキング"ライト"クミ	MARKING LIGHT ASSEMBLY	
18-4 1	S08367000	1	ライト"マーカ	MARKING LIGHT	
18-4 1 1	S08017000	2	オスピン5006TL	PIN	
18-5	018502022	1	アナホ"ルト5X20	BOLT 5X20	
18-6	018503022	2	アナホ"ルト5X30	BOLT 5X30	
18-7	101125000	2	マルモクネシ"6.2X32	SCREW 6.2X32	
18-8	028050242	3	ハ"ネサ"カ"ネ2-5	SPRING WASHER 2-5	
18-9	149547000	1	コート"オサ"4N	CORD HOLDER 4N	
18-10	146202000	2	ナイロン"クリップ"6N	NYLON CLIP 6N	
18-11	052400806	2	ナヘ"コハ"ネヒラ4X8	WASHER SCREW 4X8	
18-12	062400806	3	ナヘ"コ4X8	SCREW 4X8	
18-13	025040233	3	ヒラサ"カ"ネチユウ4	PLAIN WASHER 4	
19	S08137000	1	ランフ"5W	LAMP 5W	
20	S04159000	5	バンド"1M	BAND 1M	

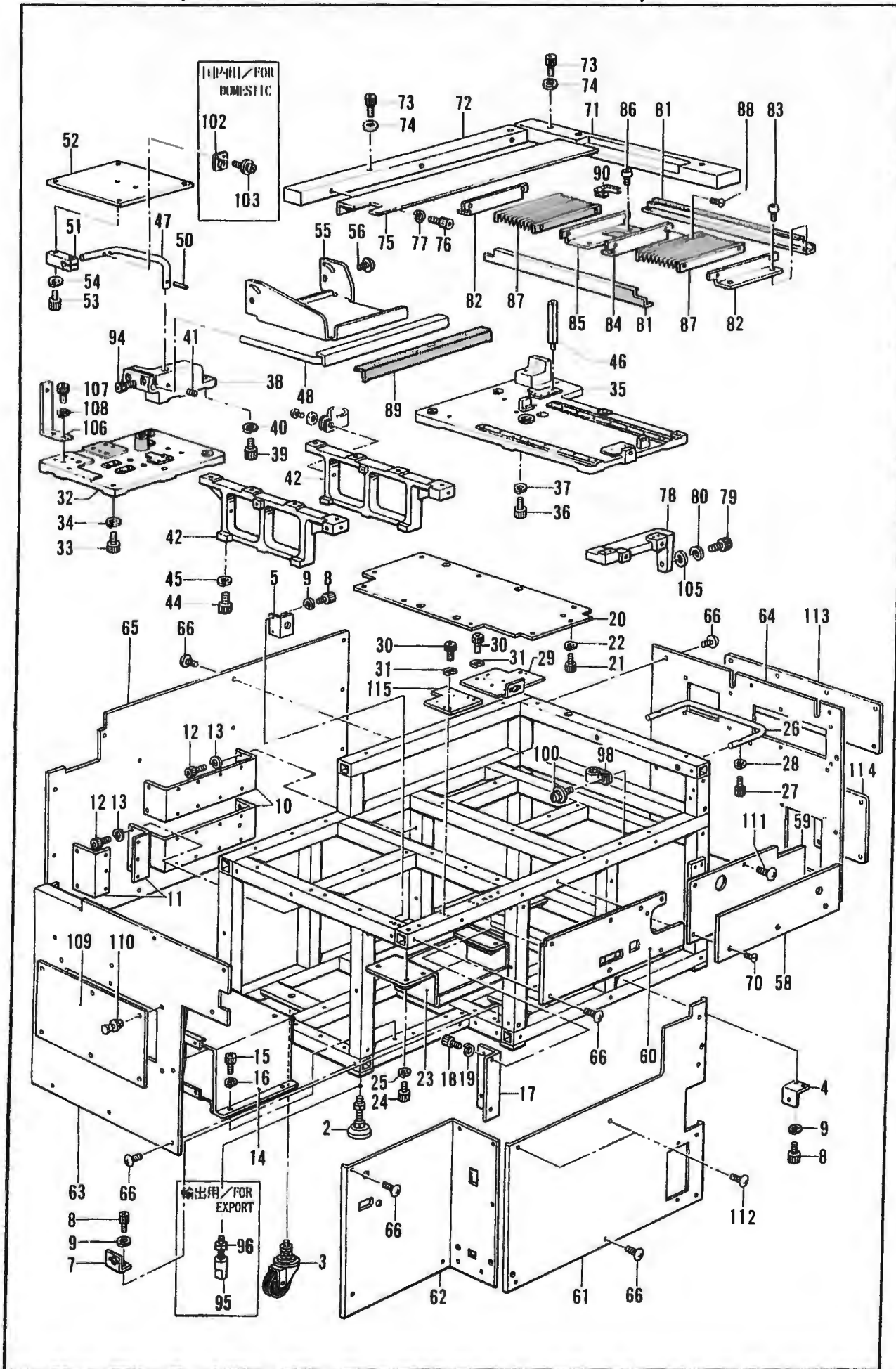

Mécanisme du plateau de la machine / Mecanismo de la mesa de la máquina

REI NO	CODE	Q'TY	ヒンメイ	NAME OF PARTS	RMKS
2	S11950000	6	レベル"ルサ"20	LEVEL ADJUSTER 20	
3	S12225000	4	キヤスター100	CASTER 420	
4	S12226001	1	カバー"トリツクイタ	COVER SET PLATE	
5	S12227001	1	バルブ"トリツクイタ	VALVE SET PLATE	
7	S12229001	1	コネクタ"トリツクイタB	CONNECTOR SET PLATE (B)	
8	018400832	6	アナボ"ルト4X8	BOLT 4X8	
9	028040242	6	ハ"ネサ"カ"ネ2-4	SPRING WASHER 2-4	
10	S12230001	2	キハ"ンササEA	CIRCUIT BOARD BASE PLATE (A)	
11	S12231001	2	キハ"ンササEB	CIRCUIT BOARD BASE PLATE (B)	
12	018400832	12	アナボ"ルト4X8	BOLT 4X8	
13	028040242	12	ハ"ネサ"カ"ネ2-4	SPRING WASHER 2-4	
14	S12232001	1	キハ"ンフレーム	CIRCUIT BOARD FRAME	
15	018400832	4	アナボ"ルト4X8	BOLT 4X8	
16	028040242	4	ハ"ネサ"カ"ネ2-4	SPRING WASHER 2-4	
17	S12233001	1	スイッチ"トリツクイタA	SWITCH SET PLATE (A)	
18	018400832	2	アナボ"ルト4X8	BOLT 4X8	
19	028040242	2	ハ"ネサ"カ"ネ2-4	SPRING WASHER 2-4	
20	S12234000	1	シヤヘイカバー	SHIELDING COVER	
21	018400832	9	アナボ"ルト4X8	BOLT 4X8	
22	028040242	9	ハ"ネサ"カ"ネ2-4	SPRING WASHER 2-4	
23	S12235009	1	ツールボ"ックス	TOOL BOX	
24	018400832	4	アナボ"ルト4X8	BOLT 4X8	
25	028040242	4	ハ"ネサ"カ"ネ2-4	SPRING WASHER 2-4	
26	S12236109	1	ガード"	GUARD	
27	018501222	2	アナボ"ルト5X12	BOLT 5X12	
28	028050242	2	ハ"ネサ"カ"ネ2-5	SPRING WASHER 2-5	
29	S20850001	1	フロツピ"ーササE三キ"	FLOPPY SUPPORT (R)	
30	018400822	7	アナボ"ルト4X8	BOLT 4X8	
31	028040242	7	ハ"ネサ"カ"ネ2-4	SPRING WASHER 2-4	
32	S15533009	1	ト"タ"IL	BASE (L)	
33	018082022	7	アナボ"ルト8X20	BOLT 8X20	
34	028080242	7	ハ"ネサ"カ"ネ2-8	SPRING WASHER 2-8	
35	S12239009	1	ト"タ"IR	BASE (R)	
36	018082022	9	アナボ"ルト8X20	BOLT 8X20	
37	028080242	9	ハ"ネサ"カ"ネ2-8	SPRING WASHER 2-8	
38	S15547009	1	ハ"ネルト"タ"イ	PANEL BASE	
39	018082022	3	アナボ"ルト8X20	BOLT 8X20	
40	028080242	3	ハ"ネサ"カ"ネ2-8	SPRING WASHER 2-8	
41	014060632	1	アナトメ6X6クボ"ミ	SET SCREW 6X6	
42	S12241009	2	ハリイタ"タ"IL	NEEDLE PLATE BASE (L)	
44	018081422	6	アナボ"ルト8X14	BOLT 8X14	
45	028080242	6	ハ"ネサ"カ"ネ2-8	SPRING WASHER 2-8	
46	S12243001	1	ハリイタ"タ"IA	NEEDLE PLATE BASE (A)	
47	S12244001	1	ハ"ネルササEホ"ウ	PANEL SUPPORT STUD	
48	S12359001	1	ミゴ"ロササE	FRONT SUPPORT	
50	047502242	1	スフ"リンク"ピンAW5	SPRING PIN AW5	
51	S12246001	1	ハ"ネルササE	PANEL SUPPORT	
52	S12247001	1	ソウサボ"ックスシタ	OPERATION BOX LOWER	
53	018502522	2	アナボ"ルト5X25	BOLT 5X25	
54	028050242	2	ハ"ネサ"カ"ネ2-5	SPRING WASHER 2-5	
55	S17708009	1	ホ"ケツトウケL	POCKET UNDER TRAY (L)	
56	008400604	4	+トラスコ4X6	SCREW 4X6	
58	*	1	スポンジ"3X170X500	SPONGE 3X170X500	
59	*	1	アテイタ	CAUL	
60	S12251009	1	ゼ"ンメンカバー"ヒタ"リ	FRONT COVER (L)	
61	S12252009	1	ゼ"ンメンカバー"三キ"	FRONT COVER (R)	
62	S12253009	1	ゼ"ンメンカバー"L	FRONT COVER (L)	
63	S15557009	1	ソクメンカバー"L	FRAME SIDE COVER (L)	
64	S17720009	1	ソクメンカバー"R	FRAME SIDE COVER (R)	
65	S15534009	1	ハイメンカバー	BACK FACE COVER	
66	008400604	51	+トラスコ4X6	SCREW 4X6	
70	*	3	サラネシ"4X8	SCREW 4X8	

B1. 動力台関係 / Power table / Motorgestell /
 Mécanisme du plateau de la machine / Mecanismo de la mesa de la máquina

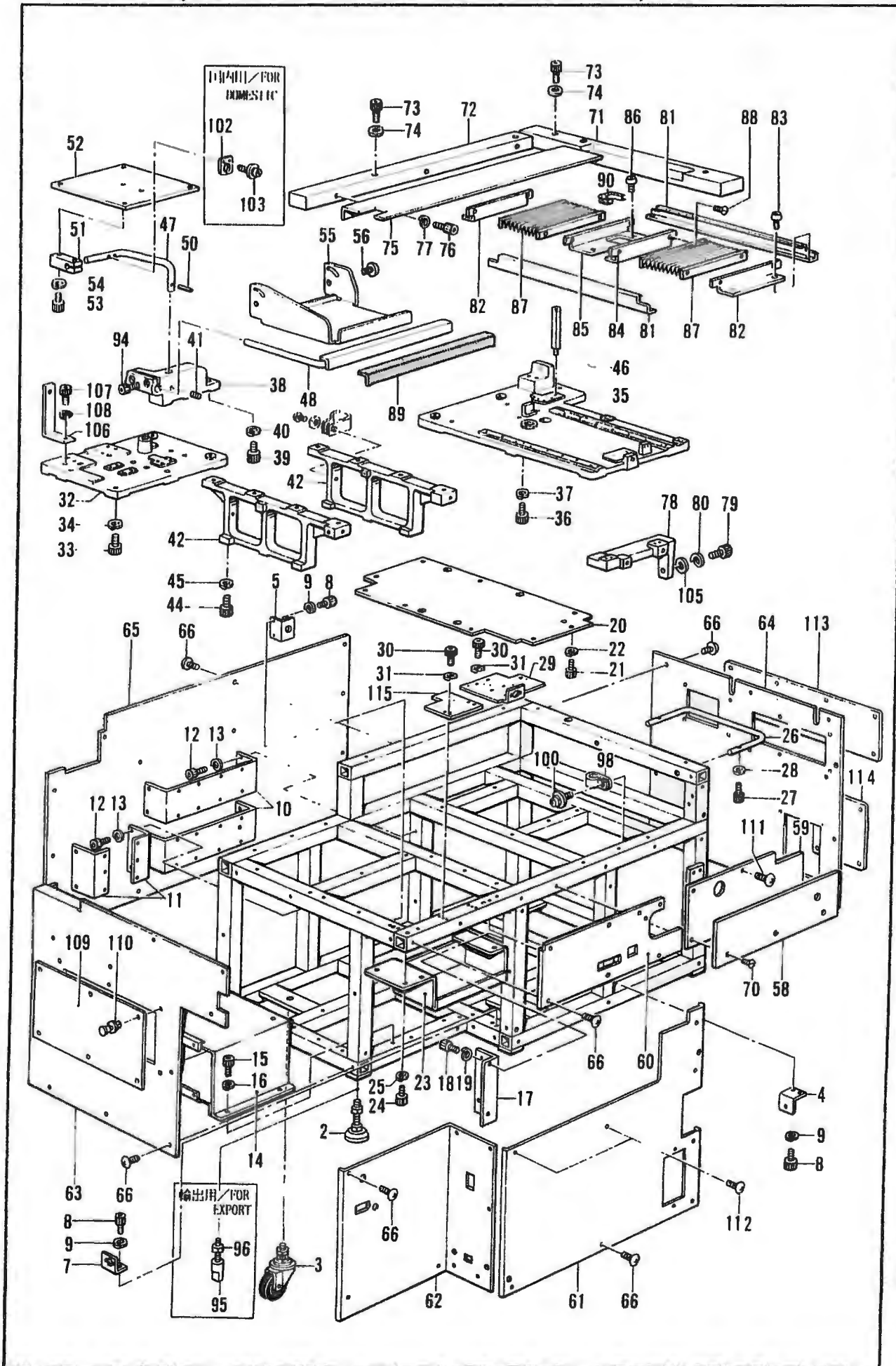

B1. 動力台関係 / Power table / Motorgestell /

Mécanisme du plateau de la machine / Mecanismo de la mesa de la máquina

REF NO	CODE	Q'TY	品名	NAME OF PARTS	RMKS
71	S12257109	1	テーブルS	TABLE (S)	
72	S12258109	1	テーブルL	TABLE (L)	
73	018401622	4	アナボルト4X16	BOLT 4X16	
74	025040232	4	ヒラサ"カ"ネチユウ4	PLAIN WASHER 4	
75	S12259009	1	テーブルカバー	TABLE COVER	
76	018501222	3	アナボルト5X12	BOLT 5X12	
77	028050242	3	ハ"ネサ"カ"ネ2-5	SPRING WASHER 2-5	
78	S12260009	1	ローラーササエ	ROLLER SUPPORT	
79	018082022	2	アナボルト8X20	BOLT 8X20	
80	028080242	2	ハ"ネサ"カ"ネ2-8	SPRING WASHER 2-8	
81	S12261001	2	シ"ヤハ"ラカカバー	BELLOW COVER	
82	S12262001	2	シ"ヤハ"ラトリツケイタA	BELLOW SET PLATE (A)	
83	062681012	8	ナヘ"コ437-40X10	SCREW 437X10	
84	S12263001	1	シ"ヤハ"ラトリツケイタB	BELLOW SET PLATE (B)	
85	S12264001	1	シ"ヤハ"ラトリツケイタC	BELLOW SET PLATE (C)	
86	062681012	4	ナヘ"コ437-40X10	SCREW 437X10	
87	S12265001	2	シ"ヤハ"ラクミ	BELLOW ASSEMBLY	
88	004400702	8	トサラネジ"4X7	SCREW 4X7	
89	S12280100	1	スポンジ"2X440X60	SPONGE 2X44X60	
90	S12466000	1	シ"サ"イフ"ツシユB	FREE BUSH (B)	
94	018502022	2	アナボルト5X20	BOLT 5X20	
95	S12356001	6	-----	STAND	
96	021200203	10	-----	NUT 20	
98	525907000	1	コードホルダ"9N	CORD HOLDER 9N	
100	052400806	1	ナヘ"コハ"ネヒラ4X8	WASHER SCREW 4X8	
105	025080232	2	ヒラサ"カ"ネチユウ 8	PLAIN WASHER 8	
106	S15528001	2	ハイメンカバー"ササエ	REAR COVER SUPPORT	
107	018401022	4	アナボルト4X10	BOLT 4X10	
108	028040242	4	ハ"ネサ"カ"ネ2-4	SPRING WASHER 2-4	
109	S15558009	1	ソクメンLフタ	FRAME	
110	S12481000	18	ナイラツチ	NYLATCH	
111	*	3	+トラスコ4X8	SCREW 4X8	
112	*	3	+トラスコ4X6	SCREW 4X6	
113	S17722009	1	ソクメンカバー"Rフタウエ	FRAME SIDE COVER (R) UPPER CAP	
114	S17721009	1	ソクメンカバー"Rフタシタ	FRAME SIDE COVER (R) LOWER CAP	
115	S20851000	1	フロツビ"ササエヒタ"リ	FLOPPY SUPPORT (L)	
〈コクナイヨウ オプション〉					
102	S12506001	1	エアガンフック	-----	
103	052400806	2	ナヘ"コハ"ネヒラ4X8	-----	

C1. 踏板関係 / Foot switch pedal mechanism / Fußbetätigung /
Mecanismo de la pédale / Mecanismo del pedal

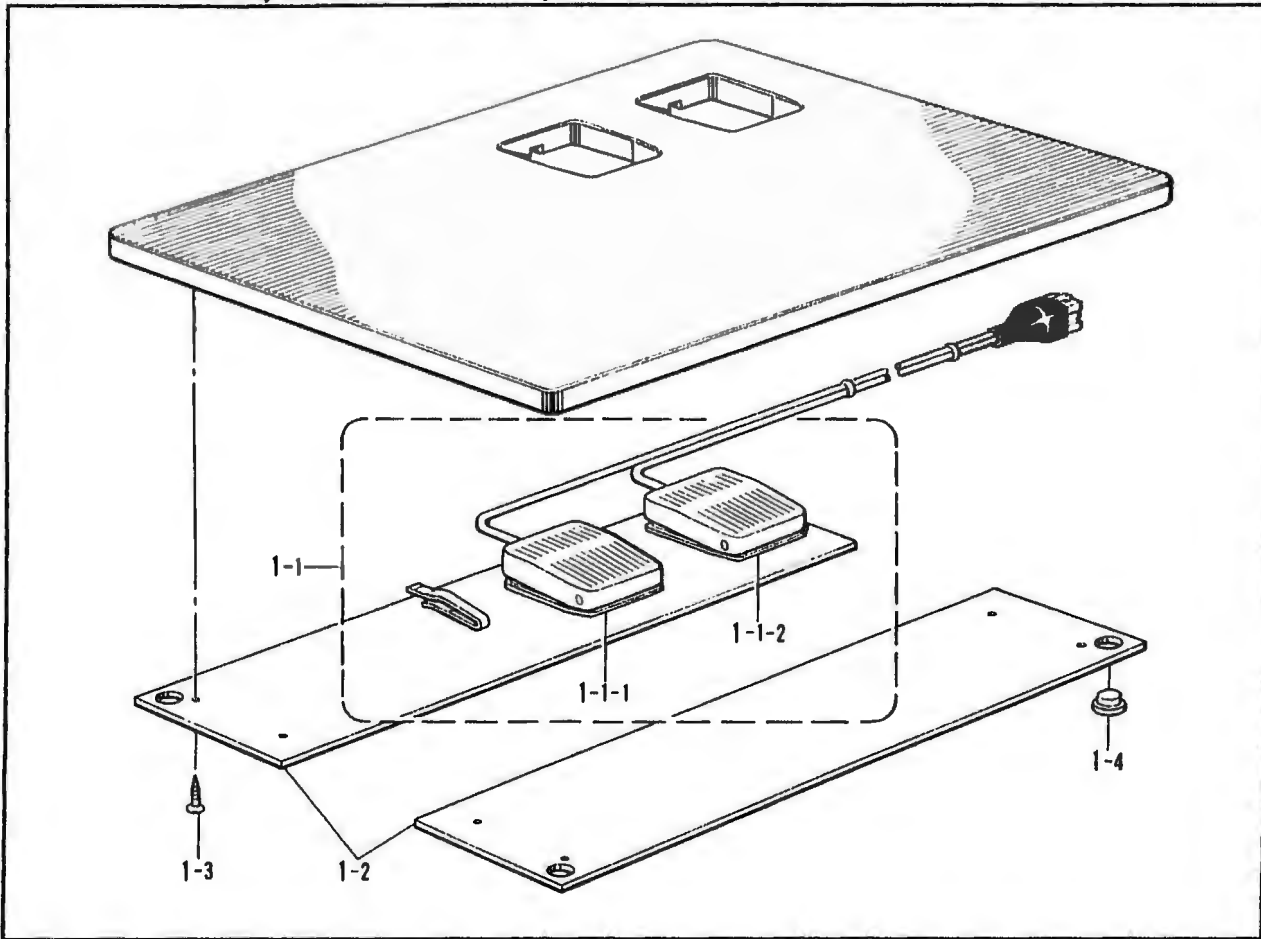

D1. 付属装置セット / Attachment set / Anbausatz /
Jeu d'accessoires / Juego del fijación

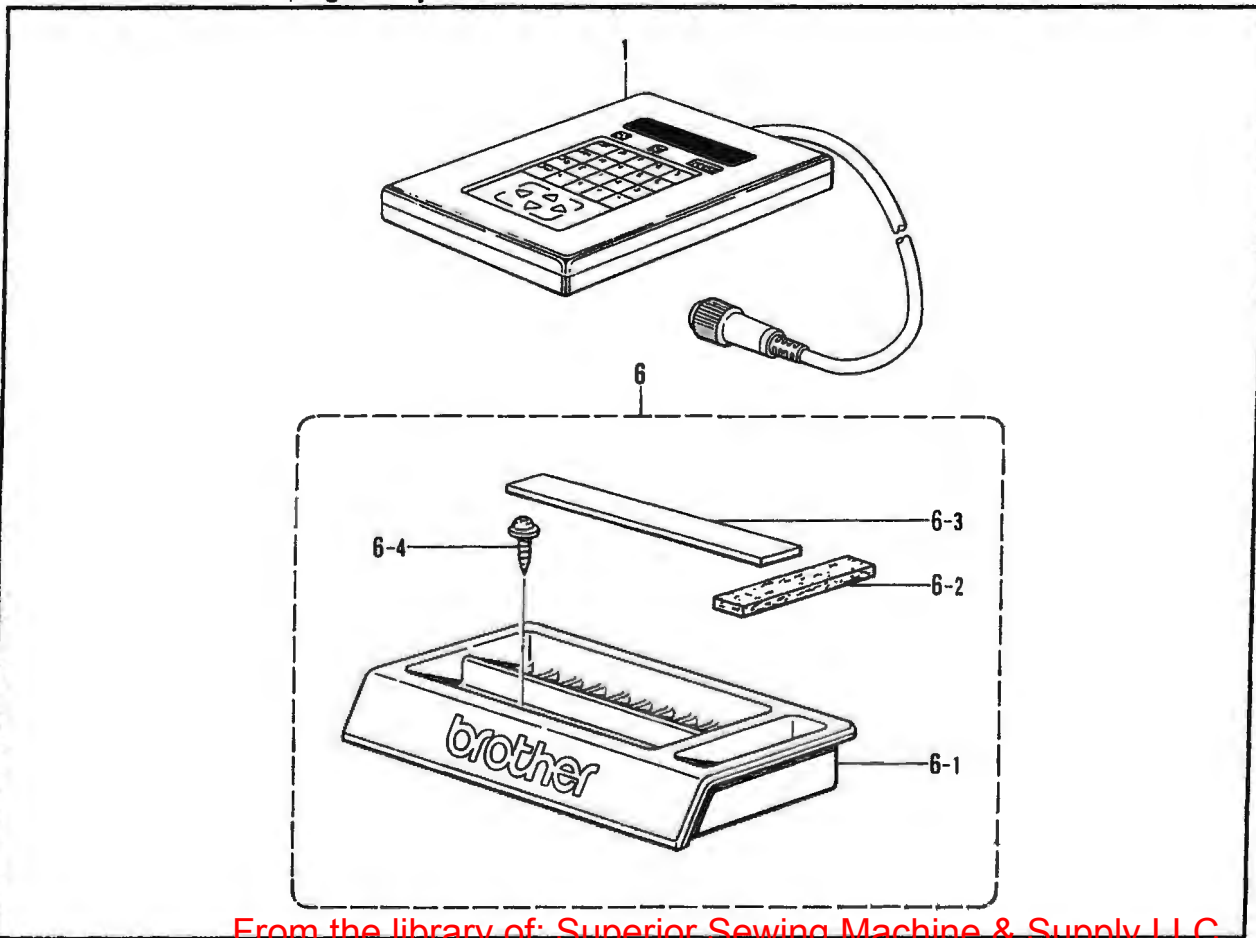

C1. 踏板関係 / Foot switch pedal mechanism / Fußbetätigung /
Mécánisme de la pédale / Mecanismo del pedal

REF NO	CODE	Q'TY	ヒンメイ	NAME OF PARTS	RMKS
1	S12222009	1	フットスイッチイタルクミ	FOOT SWITCH PLATE (L) ASSEMBLY	
1 1	S06550001	1	フットスイッチ2タ"ンクミ	FOOT SWITCH 2 STAGE ASSEMBLY	
1 1 1	S06551101	1	2タ"ンスイッチクミ	2 STAGE SWITCH ASSEMBLY	
1 1 2	S06552000	1	1タ"ンスイッチ	1 STAGE SWITCH	
1-2	S01824000	2	スイッチウケ	SWITCH SUPPORT	
1-3	034311302	10	サヲモクネシ"3.1X13	SCREW 3.1X13	
1-4	159150009	4	カマシ"クメクラセン	OIL CAP	

D1. 付属装置セット / Attachment set / Anbausatz /
Jeu d'accessoires / Juego del fijación

REF.NO.	CODE	Q'TY	ヒンメイ	NAME OF PARTS	RMKS
1	S02939009	1	プログラマクミ	PROGRAMMER ASSEMBLY	
6	183400009	1	コモノケースセット	ACCESSORY CASE SET	
6-1	S02738009	1	コモノケース	ACCESSORY CASE	
6-2	S02740000	1	フェルト	FELT	
6-3	S02739000	1	ゴムシ"シヤクテープ"	RUBBER MAGNET TAPE	
6-4	S10476001	2	ハンワツシヤタツヒ"ンネシ"	SCREW	

D2. 付属装置セット/Attachment set/Anbausatz/
Jeu d'accessoires/Juego del fijación

2-7

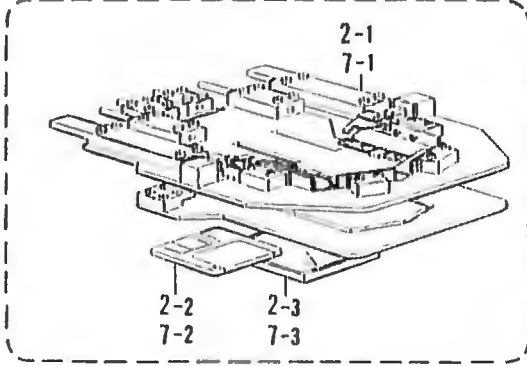

3-8

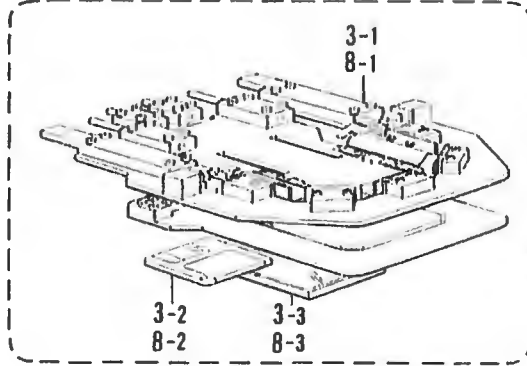

4-9

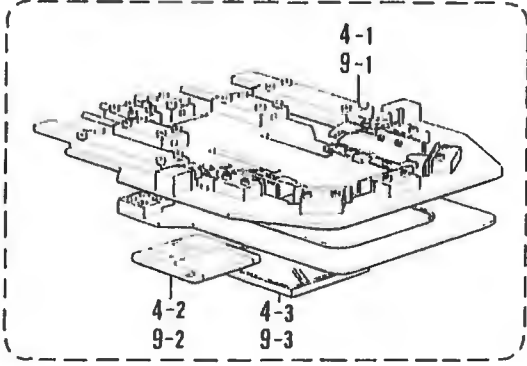

5-10

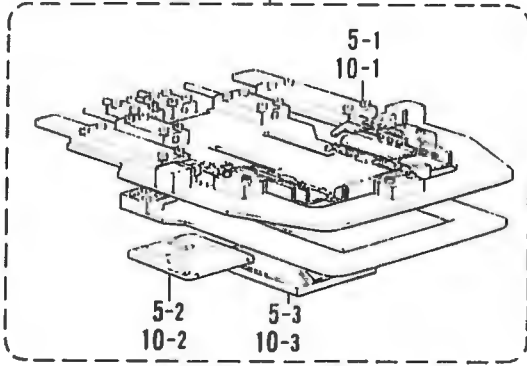

11

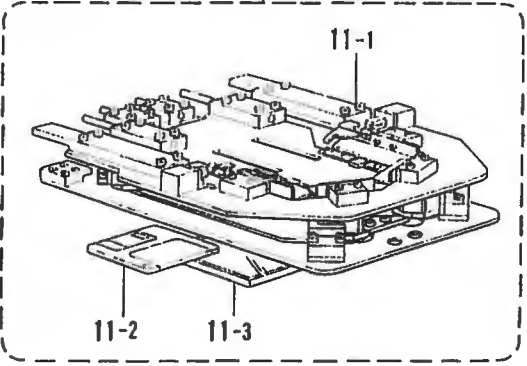

12

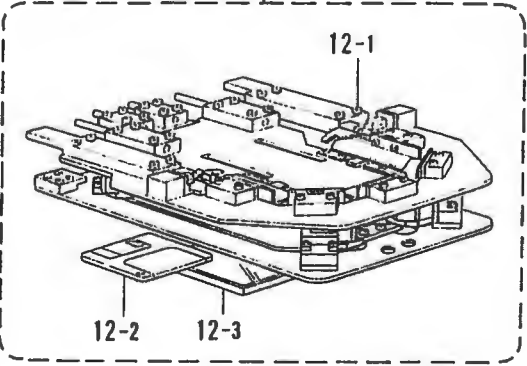

13

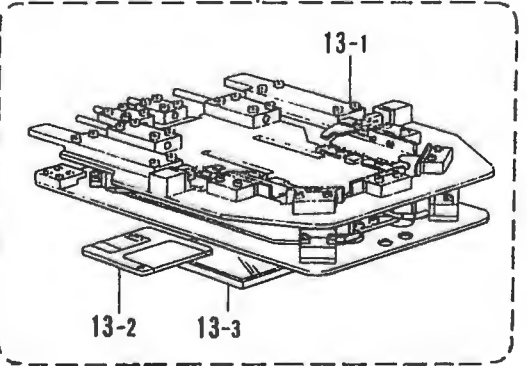

14

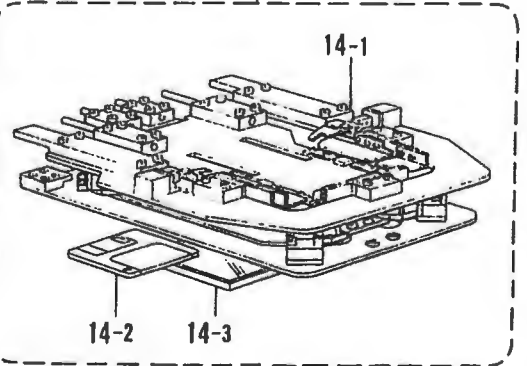

DZ. 1の機頭セット/Attachment set/Anbausatz/
Jeu d'accessoires/Juego del fijación

REF NO	CODE	Q'TY	品名	NAME OF PARTS	RMKS
2	S12272001	1	オリキホキユウクミ-3カク	FOLDING GROUP SUPPLY ASSEMBLY (TRIANGLE)	
2-1	S12283001	1	オリキクミ-3カク	FOLDING GROUP ASSEMBLY (TRIANGLE)	
2-2	U42775001	1	3.5メデ"イア 2DD	3.5 MEDIA 2DD	
2-3	S09989000	1	フロツビ"ーケース	FLOPPY CASE	
3	S12273001	1	オリキホキユウクミ-5カク	FOLDING GROUP SUPPLY ASSEMBLY (TRIANGLE)	
3-1	S12305001	1	オリキクミ-5カク	FOLDING GROUP ASSEMBLY (MITER)	
3-2	U42775001	1	3.5メデ"イア 2DD	3.5-MEDIA 2DD	
3-3	S09989000	1	フロツビ"ーケース	FLOPPY CASE	
4	S12274001	1	オリキホキユウクミ-マル	FOLDING GROUP SUPPLY ASSEMBLY (ROUND)	
4-1	S12323001	1	オリキクミ-マル	FOLDING GROUP ASSEMBLY (ROUND)	
4-2	U42775001	1	3.5メデ"イア 2DD	3.5-MEDIA 2DD	
4-3	S09989000	1	フロツビ"ーケース	FLOPPY CASE	
5	S12281001	1	オリキホキユウクミ-4カク	FOLDING GROUP SUPPLY ASSEMBLY (SQUARE)	
5-1	S12341001	1	オリキクミ-4カク	FOLDING GROUP ASSEMBLY (SQUARE)	
5-2	U42775001	1	3.5メデ"イア 2DD	3.5-MEDIA 2DD	
5-3	S09989000	1	フロツビ"ーケース	FLOPPY CASE	
7	S12488001	1	オリキホキユウクミ-3カクL	FOLDING GROUP SUPPLY ASSEMBLY (TRIANGLE)	
7-1	S12283001	1	オリキクミ-3カク	FOLDING GROUP ASSEMBLY (TRIANGLE)	
7-2	U42775001	1	3.5メデ"イア 2DD	3.5-MEDIA 2DD	
7-3	S09989000	1	フロツビ"ーケース	FLOPPY CASE	
8	S12489001	1	オリキホキユウクミ-5カクL	FOLDING GROUP SUPPLY ASSEMBLY (MITER)(L)	
8-1	S12305001	1	オリキクミ-5カク	FOLDING GROUP ASSEMBLY (MITER)	
8-2	U42775001	1	3.5メデ"イア 2DD	3.5-MEDIA 2DD	
8-3	S09989000	1	フロツビ"ーケース	FLOPPY CASE	
9	S12490001	1	オリキホキユウクミ-マルL	FOLDING GROUP SUPPLY ASSEMBLY (ROUND)(L)	
9-1	S12323001	1	オリキクミ-マル	FOLDING GROUP ASSEMBLY (ROUND)	
9-2	U42775001	1	3.5メデ"イア 2DD	3.5-MEDIA 2DD	
9-3	S09989000	1	フロツビ"ーケース	FLOPPY CASE	
10	S12491001	1	オリキホキユウクミ-4カクL	FOLDING GROUP SUPPLY ASSEMBLY (SQUARE)(L)	
10-1	S12341001	1	オリキクミ-4カク	FOLDING GROUP ASSEMBLY (SQUARE)	
10-2	U42775001	1	3.5メデ"イア 2DD	3.5-MEDIA 2DD	
10-3	S09989000	1	フロツビ"ーケース	FLOPPY CASE	
11	S19587001	1	オリキホキユウクミ-3カク2	FOLDING GROUP SUPPLY ASSEMBLY (TRIANGLE-2)	
11-1	S19561001	1	オリキクミ-3カク2	FOLDING GROUP ASSEMBLY (TRIANGLE-2)	
11-2	U42775001	1	3.5メデ"イア 2DD	3.5-MEDIA 2DD	
11-3	S09989000	1	フロツビ"ーケース	FLOPPY CASE	
12	S19588001	1	オリキホキユウクミ-5カク2	FOLDING GROUP SUPPLY ASSEMBLY (MITER-2)	
12-1	S19567001	1	オリキクミ-5カク2	FOLDING GROUP ASSEMBLY (MITER-2)	
12-2	U42775001	1	3.5メデ"イア 2DD	3.5-MEDIA 2DD	
12-3	S09989000	1	フロツビ"ーケース	FLOPPY CASE	
13	S19589001	1	オリキホキユウクミ-マル2	FOLDING GROUP SUPPLY ASSEMBLY (ROUND-2)	
13-1	S19573001	1	オリキクミ-マル2	FOLDING GROUP ASSEMBLY (ROUND-2)	
13-2	U42775001	1	3.5メデ"イア 2DD	3.5-MEDIA 2DD	
13-3	S09989000	1	フロツビ"ーケース	FLOPPY CASE	
14	S19590001	1	オリキホキユウクミ-4カク2	FOLDING GROUP SUPPLY ASSEMBLY (SQUARE-2)	
14-1	S19579001	1	オリキクミ-4カク2	FOLDING GROUP ASSEMBLY (SQUARE-2)	
14-2	U42775001	1	3.5メデ"イア 2DD	3.5-MEDIA 2DD	
14-3	S09989000	1	フロツビ"ーケース	FLOPPY CASE	

D3. 付属装置セット/Attachment set/Anbausatz/
 Jeu d'accessoires/Juego del fijación

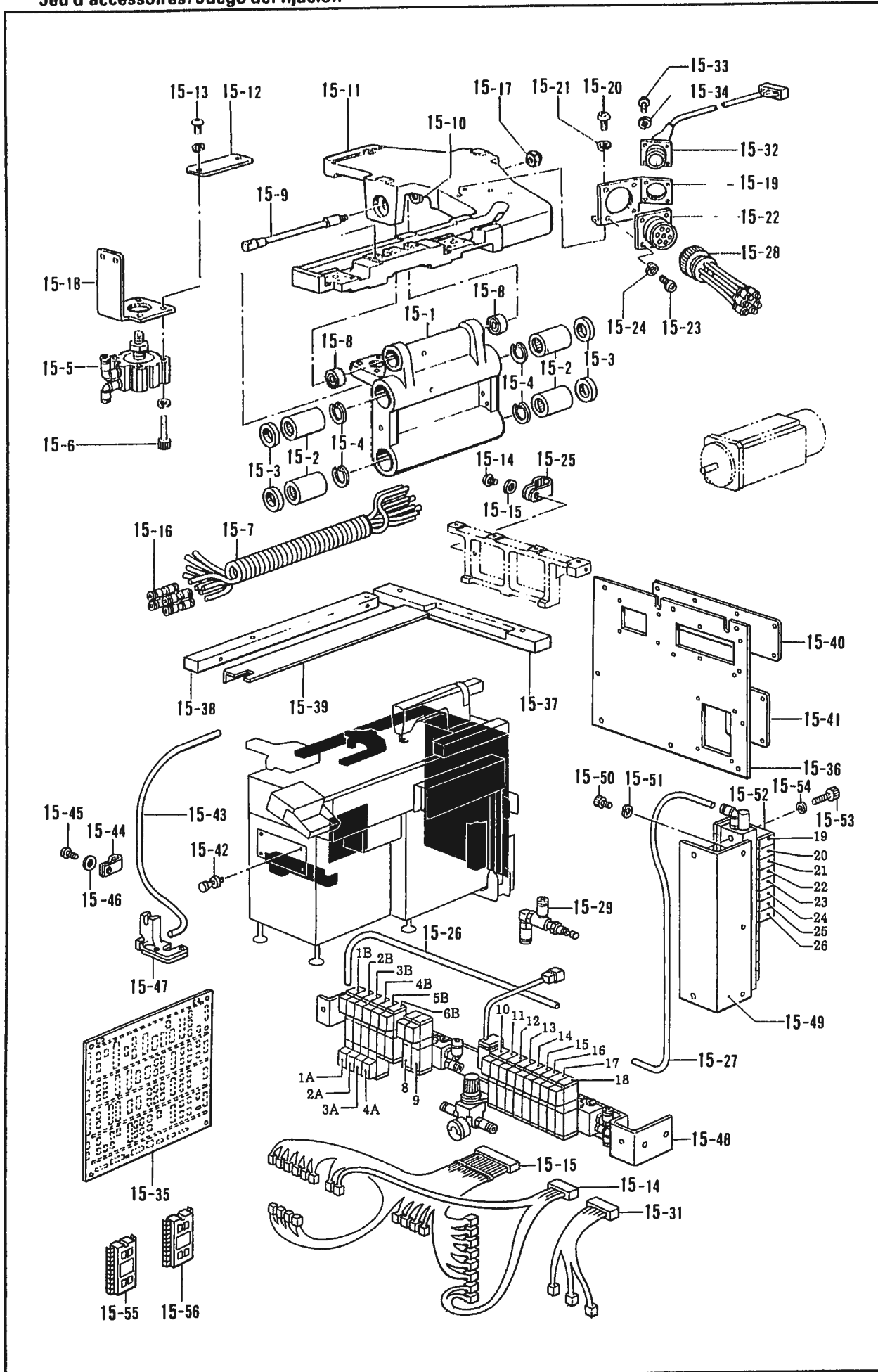

U3. 付属品セット / Attachment set / Anbausatz /
Jeu d'accessoires / Juego del fijación

RLI NO	CODE	Q'TY	ヒンメイ	NAME OF PARTS	RMKS
15	S19516001	1	2レツペンコウフ"ヒンクミ	CONVERSION ASSEMBLY 1	
15 1	S17719009	1	オサエサエ	PRESSER SUPPORT	
15 2	S12035000	4	リニアボールベアリング	LINEAR BALL BEARING	
15 3	S12036000	4	クミアフセシール	COMBINATION SEAL	
15 4	048350242	4	トメワアナヨウC35	STOP RING C35	
15 5	S17725000	1	シリンダ"40X5クミ	CYLINDER 40X5 ASSEMBLY	
15 6	S19553000	4	CQ2ボルトM5X40	CQ2 BOLT M5X40	
15 7	S17727000	1	コイルチューブ	COIL TUBE	
15 8	S12045000	2	アンキ"ユラタマシ"クウク1	ANGULAR BALL BEARING 1	
15 9	S15538001	1	ホ"ケツトオサエシ"ク	POCKET PRESSER SHAFT	
15 10	S15539001	1	カラ"2-15	COLLAR 2-15	
15 11	S17716009	1	オサエ	PRESSER FOOT	
15 12	S17717009	1	オサエカハ"ー	COVER	
15 13	008400604	2	トラスコ4X6	SCREW 4X6	
15 14	062400806	1	ナ"コ4X8	SCREW 4X8	
15 15	025040233	1	ヒラサ"カ"ネチユウ4	PLAIN WASHER 4	
15 16	S04587000	6	ストレートツキ"テ	STRAIGHT JOINT	
15 17	S15545000	1	UナットM8P1	U-NUT M8P1	
15 18	S17724001	1	センサートリツケイタシタ	SENSOR SET PLATE LOWER	
15 19	S19066001	1	マルチコネクタートリツケ	MULTI CONNECTOR SET PLATE	
15 20	062401006	2	ナ"コ4X10	SCREW 4X10	
15 21	028040243	2	ハ"ネサ"カ"ネ2-4	SPRING WASHER 2-4	
15 22	S19550000	1	マルチコネクタ"6S	MULTI CONNECTOR (6S)	
15 23	062400812	4	ナ"コ4X8	SCREW 4X8	
15 24	028040242	4	ハ"ネサ"カ"ネ2-4	SPRING WASHER 2-4	
15 25	554482000	1	コート"ホルダ"12N	CORD HOLDER 12N	
15 26	S19585000	2	エア"ホース"6X4-6	AIR TUBE 6X4-6 (L - 230)	
15 27	S19586000	1	エア"ホース"6X4-7	AIR TUBE 6X4-7 (L=1200)	
15 28	S19554000	1	マルチコネクタ"6Pクミ	MULTI CONNECTOR (6P) ASSEMBLY	
15 29	S19971000	1	ゲ"ンアツハ"ンM5-04クミ	REDUCING VALVE M5-04 ASSEMBLY	
15 30	S19509000	1	オサエアシハーネスN	WORK CLAMP HARNESS (N)	
15 31	S19510000	1	ソレノイド"クト"ウハーネスN	SOLENOID DRIVING HARNESS (N)	
15 32	S19511000	1	2レツヨウハーネス	DOUBLE ROW HARNESS	
15 33	062300606	4	ナ"コ3X6	SCREW 3X6	
15 34	028030243	4	ハ"ネサ"カ"ネ2-3	SPRING WASHER 2-3	
15 35	S19513000	1	メインキハ"ンクミN	MAIN CIRCUIT BOARD ASSEMBLY (N)	
15 36	S17720009	1	ソクメンカハ"ーR	FRAME SIDE COVER (R)	
15 37	S12257109	1	テーブルS	TABLE (S)	
15 38	S12258109	1	テーブルL	TABLE (L)	
15 39	S12259009	1	テーブルカハ"ー	TABLE COVER	
15 40	S17722009	1	ソクメンカハ"ーRフタウエ	FRAME SIDE COVER (R) UPPER CAP	
15 41	S17721009	1	ソクメンカハ"ーRフタシタ	FRAME SIDE COVER (R) LOWER CAP	
15 42	S12481000	12	ナイラツチ	NYLATCH	
15 43	S19080000	1	エア"ホース"4X2.5	AIR TUBE 4X2.5	
15 44	149547000	1	コート"オサエ	CORD HOLDER	
15 45	062401006	1	ナ"コ4X10	SCREW 4X10	
15 46	025040233	1	ヒラサ"カ"ネチユウ4	PLAIN WASHER 4	
15 47	S19063101	1	オサエアシクミ	WORK CLAMP ASSEMBLY	
15 48	S19559001	1	ハ"ルブ"クミ2レツ	VALVE ASSEMBLY (DOUBLE ROW)	
15 49	S17723001	1	ハ"ルブ"トリツケイタミキ"	VALVE SET PLATE (RIGHT)	
15 50	018400832	3	アナボルト4X8	BOLT 4X8	
15 51	028040242	3	ハ"ネサ"カ"ネ2-4	SPRING WASHER 2-4	
15 52	S17728001	1	ハ"ルブ"14クミ	VALVE 14 ASSEMBLY	
15 53	018503022	2	アナボルト5X30	BOLT 5X30	
15 54	028050242	2	ハ"ネサ"カ"ネ2-5	SPRING WASHER 2-5	
15 55	S11837100	1	PROM750-2(オリキヨウ)	PROM 750-2 (FOR FOLDING MACHINE)	
15 56	S19518000	1	PROM751-1(メインヨウ)	PROM 751-1 (FOR MAIN)	
15 57	S19508000	1	2レツハ"ルブ"ハーネス	DOUBLE SEAM VALVE HARNESS	

D4. 付属装置セット/Attachment set/Anbausatz/
 Jeu d'accessoires/Juego del fijación

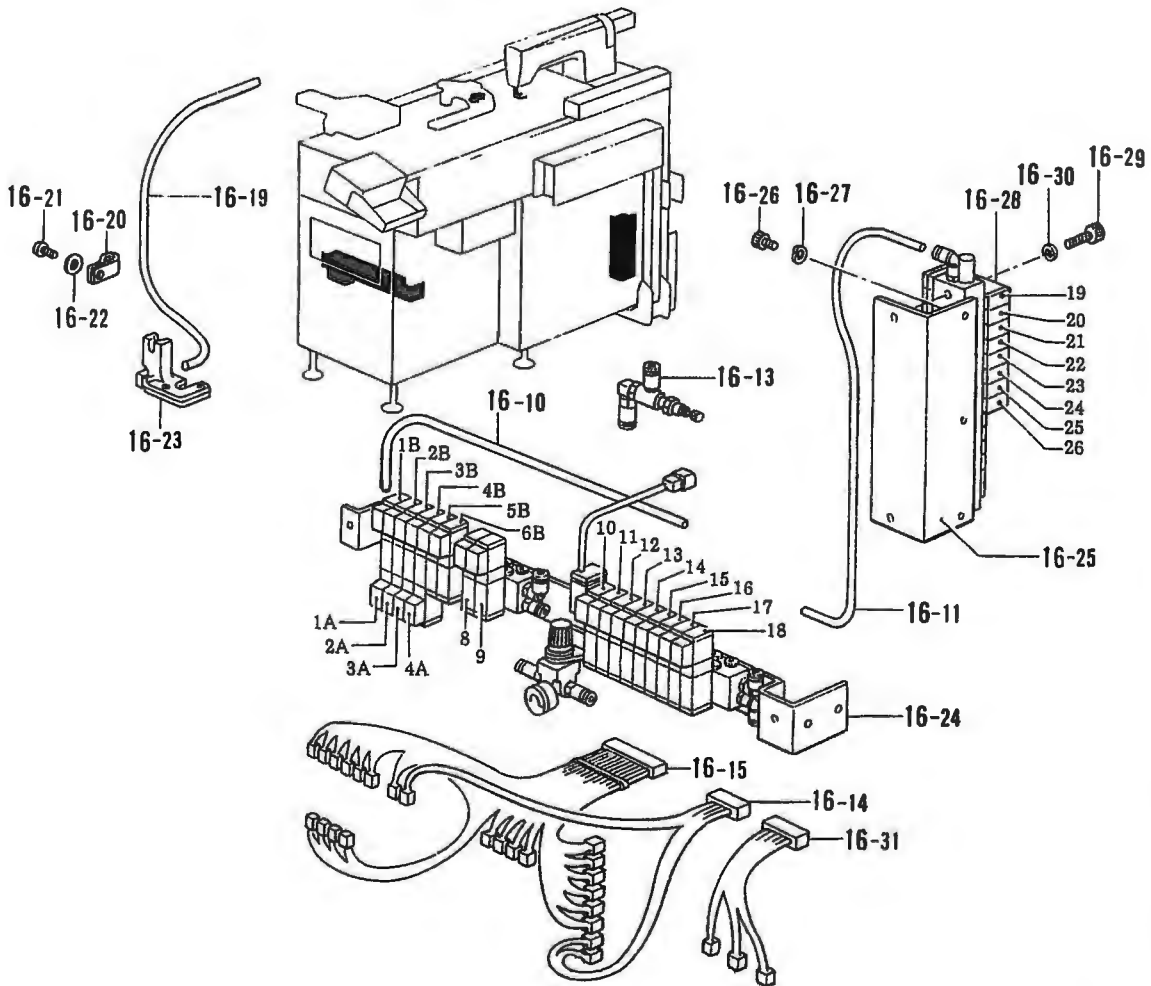
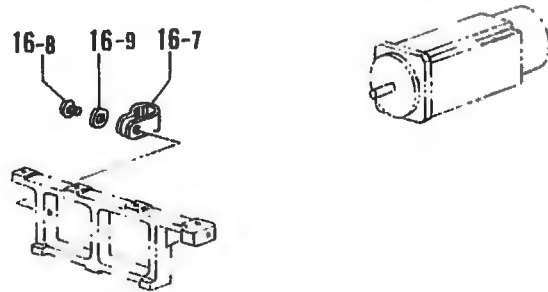
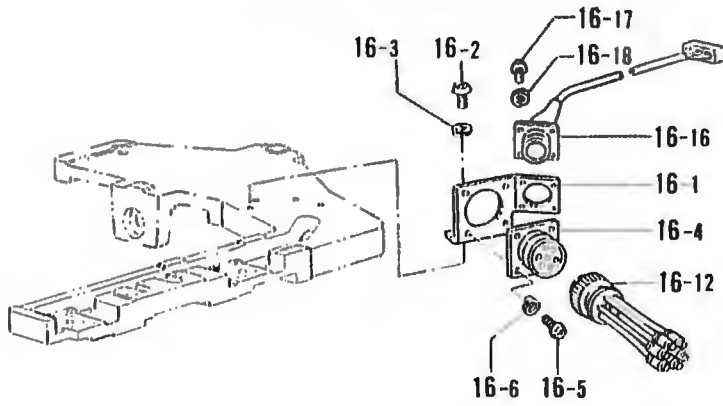

Jeu d'accessoires / Juego del fijación

RLI NO	CODE	Q'TY	品名	NAME OF PARTS	RMKS
16	S19517001	1	2レツヘンコウブ"ヒンクミ?	CONVERSION ASSEMBLY 2	
16 1	S19066001	1	マルチコネクタートリツケ	MULTI CONNECTOR SET PLATE	
16 2	062401006	2	ナヘ"コ4X10	SCREW 4X10	
16 3	028040243	2	ハ"ネサ"カ"ネ2-4	SPRING WASHER 2-4	
16 4	S19550000	1	マルチコネクタ-6S	MULTI CONNECTOR (6S)	
16 5	062400812	4	ナヘ"コ4X8	SCREW 4X8	
16 6	028040242	4	ハ"ネサ"カ"ネ2-4	SPRING WASHER 2-4	
16 7	554482000	1	コート"ホルダ"12N	CORD HOLDER 12N	
16 8	062400806	1	ナヘ"コ4X8	SCREW 4X8	
16 9	025040233	1	ヒラサ"カ"ネチユウ4	PLAIN WASHER 4	
16 10	S19585000	2	エア-ホ-ス6X4-6	AIR TUBE 6X4-6 (L-230)	
16 11	S19586000	1	エア-ホ-ス6X4-7	AIR TUBE 6X4-7 (L 1200)	
16 12	S19554000	1	マルチコネクタ-6Pクミ	MULTI CONNECTOR (6P) ASSEMBLY	
16 13	S19971000	1	ケ"ンアツハ"ンM5-04クミ	REDUCING VALVE M5-04 ASSEMBLY	
16 14	S19509000	1	オサエアシハーネスN	WORK CLAMP HARNESS (N)	
16 15	S19510000	1	ソレノイド"クト"ウハーネスN	SOLENOID DRIVING HARNESS (N)	
16 16	S19511000	1	2レツヨウハーネス	DOUBLE ROW HARNESS	
16 17	062300606	4	ナヘ"コ3X6	SCREW 3X6	
16 18	028030243	4	ハ"ネサ"カ"ネ2-3	SPRING WASHER 2-3	
16 19	S19080000	1	エアホ-ス4X2.5	AIR TUBE 4X2.5	
16 20	149547000	1	コート"オサエ	CORD HOLDER	
16 21	062401006	1	ナヘ"コ4X10	SCREW 4X10	
16 22	025040233	1	ヒラサ"カ"ネチユウ4	PLAIN WASHER 4	
16 23	S19063101	1	オサエアシクミ	WORK CLAMP ASSEMBLY	
16 24	S19559001	1	ハ"ルフ"クミ2レツ	VALVE ASSEMBLY (DOUBLE ROW)	
16 25	S17723001	1	ハ"ルフ"トリツケイタミキ"	VALVE SET PLATE (RIGHT)	
16 26	018400832	3	アナホ"ルト4X8	BOLT 4X8	
16 27	028040242	3	ハ"ネサ"カ"ネ2-4	SPRING WASHER 2-4	
16 28	S17728001	1	ハ"ルフ"14クミ	VALVE 14 ASSEMBLY	
16 29	018503022	2	アナホ"ルト5X30	BOLT 5X30	
16 30	028050242	2	ハ"ネサ"カ"ネ2-5	SPRING WASHER 2-5	
16 31	S19508000	1	2レツハ"ルフ"ハーネス	DOUBLE SEAM VALVE HARNESS	

2. 付属品関係 / Accessories / Zubehör /
Accessoires / Accesorios

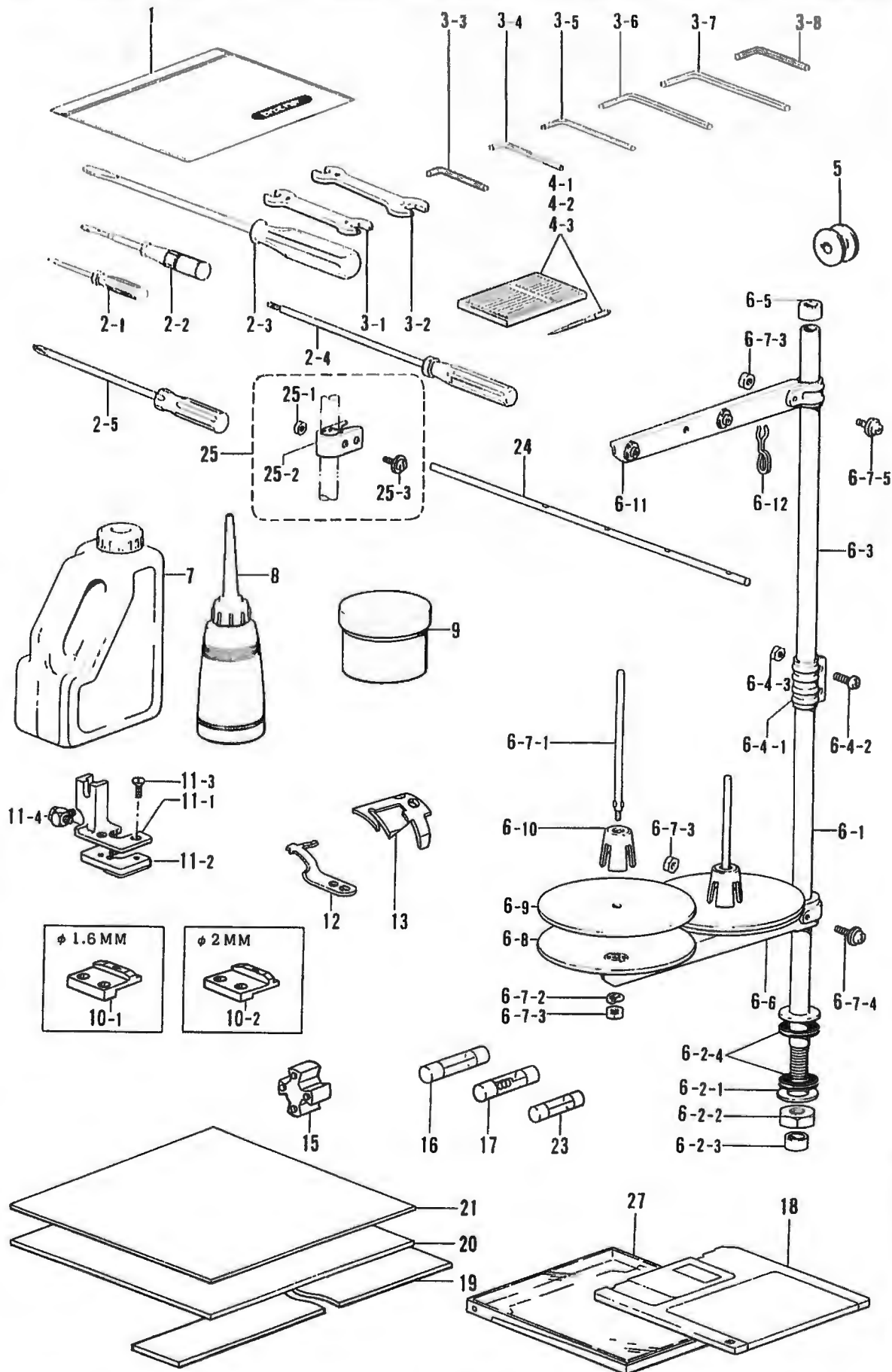

◎ 付属品の明細は変更することがあります。
 ◎ The details of included accessories are subject to change.
 ◎ Änderungen in der Aufstellung der Mitgelieferten Zubehöre sind vorbehalten.

◎ Les détails des accessoires inclus sont sujets à des changements.
 ◎ Los detalles de los accesorios incluidos pueden variar.

2. 付属品関係/Accessories/Zubehör/
Accessories/Accessorios

RII NO	CODE	QTY	ヒンメイ	NAME OF PARTS	RMKS
1	122991001	1	フックヒンホ"リフクロ	ACCESSORY BAG	
2 1	142443001	1	ネジ"マフシ1.9X52	SCREW DRIVER 1.9X52	
2 2	118837001	1	ネジ"マフシ3.4X70	SCREW DRIVER 3.4X70	
2 3	101572101	1	ネジ"マフシ5.5X190	SCREW DRIVER 5.5X190	
2 4	149173001	1	6カクホ"ウネジ"マフシ3	SCREW DRIVER 3	
2 5	150332001	1	フ"ラスト"ライハ"-NO.2	DRIVER NO.2	
3 1	100887001	1	スパ"ナ8X9	SPANNER 8X9	
3 2	107780001	1	スパ"ナ10X12	SPANNER 10X12	
3 3	146049001	1	6カクホ"ウスハ"ナ2	HEXAGONAL WRENCH 2	
3-4	142721001	1	6カクホ"ウスハ"ナ3	HEXAGONAL WRENCH 3	
3 5	118064001	1	6カクホ"ウスハ"ナ4	HEXAGONAL WRENCH 4	
3-6	150335001	1	6カクホ"ウスハ"ナ5	HEXAGONAL WRENCH 5	
3 7	115157001	1	6カクホ"ウスハ"ナ6	HEXAGONAL WRENCH 6	
3-8	154125001	1	6カクホ"ウスハ"ナ2.5	HEXAGONAL WRENCH 2.5	
4 1	S11864010	10	ミシンハリ134SERV7 (#70)	NEEDLE 134SERV7 (#70)	
4 2	S11864012	10	ミシンハリ134SERV7 (#80)	NEEDLE 134SERV7 (#80)	
4 3	S11864016	10	ミシンハリ134SERV7 (#100)	NEEDLE 134SERV7 (#100)	
5	146290001	3	ホ"ビ"ン	BOBBIN	
6	S02763202	1	イトタテタ"イクミ2DR	COTTON STAND ASSEMBLY 2DR	
6-1	156112003	1	コラムハ"イフ"D	COLUMN PIPE (D)	
6-2	S02777001	1	ハ"イフ"Dネジ"セットB	PIPE (D) SCREW SET (B)	
6-2-1	150206002	1	ヒラサ"ガ"ネ16	PLAIN WASHER 16	
6-2 2	150191002	1	6カクナツト5/8	NUT 5/8	
6-2 3	150174000	1	コラムキャツフ"	COLUMN CAP	
6-2 4	S01005000	2	イトタテゴ"ム	RUBBER WASHER	
6-3	150172003	1	コラムハ"イフ"	COLUMN PIPE	
6-4	150106003	1	コラムシ"ョイントクミ	COLUMN JOINT ASSEMBLY	
6-4 1	150173003	1	コラムシ"ョイント	COLUMN JOINT	
6-4-2	062501406	2	ナヘ"コ5X14	SCREW 5X14	
6-4-3	021500106	2	1シユナツト5	NUT 5	
6-5	150174000	1	コラムキャツフ"	COLUMN CAP	
6-6	S02778002	1	スプ"ールホルダ"ー2	SPOOL HOLDER 2	
6-7	S02780001	1	スプ"ールネジ"セット2	SPOOL SCREW SET 2	
6-7-1	150179002	2	スプ"ールシ"クB	SPOOL SHAFT (B)	
6-7-2	028050246	2	ハ"ネサ"ガ"ネ2-5	SPRING WASHER 2-5	
6-7 3	021500106	4	1シユナツト5	NUT 5	
6-7-4	050503006	1	ナヘ"コヒラサ"5X30	WASHER SCREW 5X30	
6-7-5	050501406	1	ナヘ"コヒラサ"5X14	WASHER SCREW 5X14	
6-8	150180001	2	ウケサ"ラ	SPOOL STAND BASE	
6-9	150182000	2	スプ"ールマット	SPOOL MAT	
6-10	126863001	2	スプ"ールクツシヨ"ン	SPOOL CUSHION	
6-11	S02786002	1	スレツト"ハンガ"ークミ2	THREAD HANGER ASSEMBLY 2	
6-12	S02747001	1	イトカケハ"ネ	SPRING	
7	154702001	1	オイルタンク	OIL TANK	
8	114483002	1	ホ"リオイラークミ	OILER ASSEMBLY	
9	S00966000	1	グ"リースタンク30	GREASE TUNK 30	
10-1	S11889001	1	ホ"トムフ"ランシ"ヤ (φ1.6MM)	BOTTOM PLUNGER (φ1.6MM)	
10-2	S14788001	1	ホ"トムフ"ランシ"ヤ (φ2MM)	BOTTOM PLUNGER (φ2MM)	
11	S19063101	1	オサエアシクミ	WORK CLAMP ASSEMBLY	
11-1	S19064001	1	オサエアシ	WORK CLAMP	
11-2	S19065101	1	オサエイタ	PRESSER PLATE	
11-3	102538007	2	サラネシ"3.57	SCREW 3.57	
11-4	S19068000	1	エルホ"M3	ELBOW M3	
12	S02637001	1	コテイハ	FIXED KNIFE	
13	S02645001	1	イト"ウハ	MOVABLE KNIFE	
15	152387000	1	カツプ"リンク"C	COUPLING (C)	
16	S11734000	2	ヒユース"20A	FUSE (20A)	

Z. 付属品関係/Accessories/Zubehör/
Accessoires/Accesorios

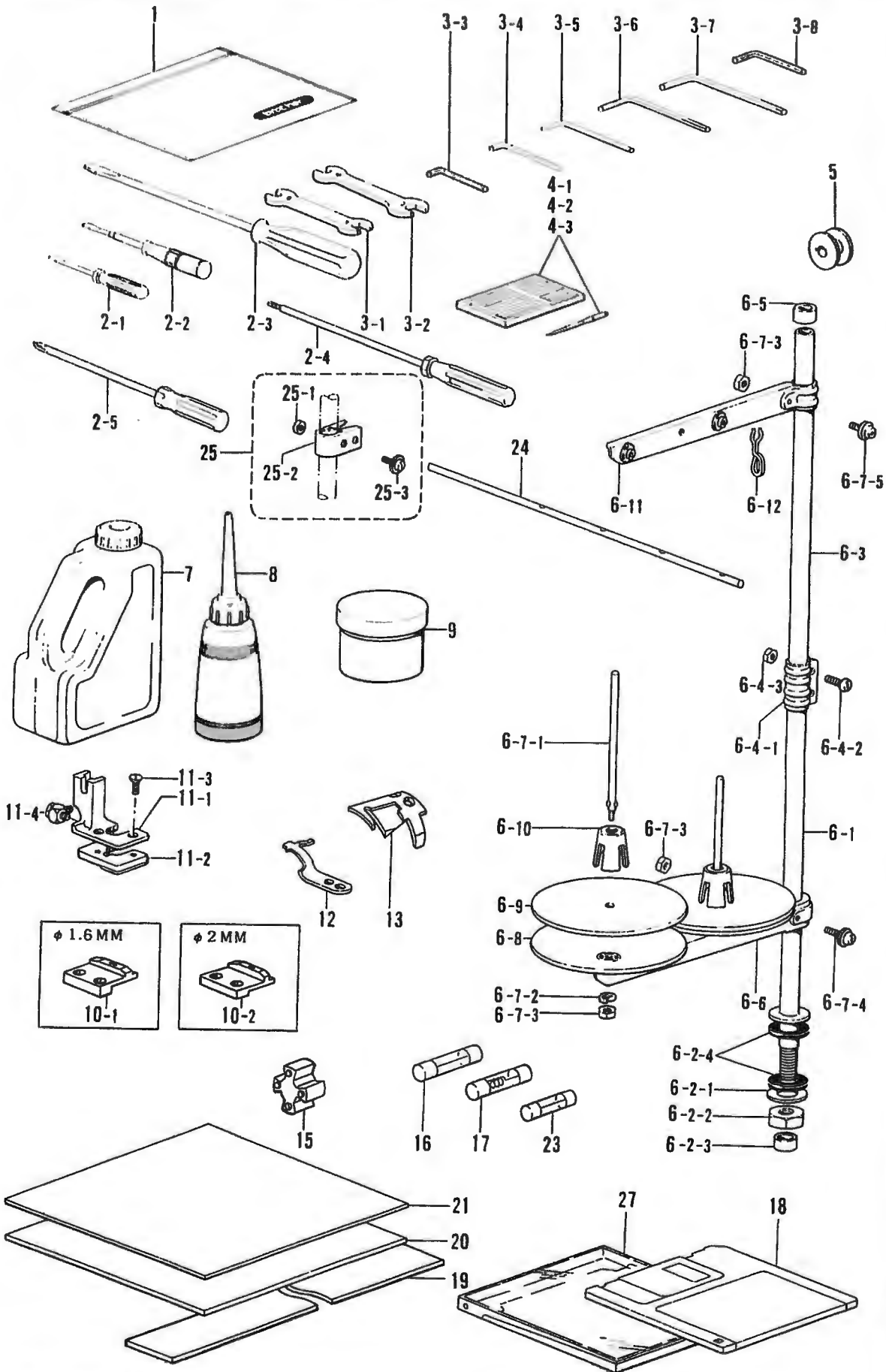

◎ 付属品の明細は変更することがあります。
 ◎ The details of included accessories are subject to change.
 ◎ Änderungen in der Aufstellung der Mitgelieferten Zubehöre sind vorbehalten.

◎ Les détails des accessoires inclus sont sujets à des changements.
 ◎ Los detalles de los accesorios incluidos pueden variar.

2. 付属品/Accessories/Zubehör/
Accessoires/Accessorios

REF NO	CODE	Q'TY	品名	NAME OF PARTS	RMKS
17	152565000	2	ヒューズ"B	FUSE (B)	
18	U42775001	2	3.5メディア2DD	3.5 MEDIA 2DD	
19	S12298000	1	フォーム3X15X1000	FORM 3X15X1000	
20	S12116000	1	スポンジ"3X200X200	SPONGE 3X200X200	
21	S12117000	1	フォーム2X200X200	FORM 2X200X200	
23	S11705000	2	スローブ"ローヒューズ"	SLOW BLOW FUSE	
24	S11959001	1	下タイトアンナイ	LOWER THREAD GUIDE	
25	150145009	1	イトアンナイホルダー"クミ	THREAD GUIDE HOLDER ASSEMBLY	
25 1	021500106	1	1 Nutナット5	NUT 5	
25 2	150185009	1	イトアンナイホルダー	THREAD GUIDE HOLDER	
25 3	050503006	1	ナハ"コヒラサ"5X30	WASHER SCREW 5X30	
27	S09989000	2	フロッピーケース	FLOPPY CASE	

仕機別部品一覧表 / DIFFERENT PARTS LIST / ZUBEHÖRLISTE /
LISTE DES PIÈCES ACCESSOIRES / LISTA DE PIEZAS ACCESORIAS

REF.NO.	サブクラス SUB CLASS ヒンメイ PARTS	20111 200V,50-60HZ FOR DOMESTIC	20121 200V,50-60HZ FOR DOMESTIC	22111 200V,50-60HZ FOR DOMESTIC	22121 200V,50-60HZ FOR DOMESTIC	30111 200V,50-60HZ FOR DOMESTIC
P-128	スタツカー(WORK)ク					
X-7	バルブ14ク VALVE 14 ASSEMBLY					S17728001
X-57	エアホース 4X2.5-15 (L=770) AIR TUBE 4X2.5-15 (L=770)	S12191000	←	←	←	←
X-79	ハキユームソウチクミ VACUUM EQUIPMENT ASSEMBLY			S12496001	←	
X-86	ハキユームウラフタ	S15544001	←			S15544001
X-87	サラネジ 4.37	100032003	←			100032003
X-93	バルブ2クミ	S19675000	←	←	←	
X-94	エアホース 4X2.5-15 (L=770) AIR TUBE 4X2.5-15 (L=770)					S12191000
X-95	エアホース 4X2.5-17 (L=890) AIR TUBE 4X2.5-17 (L=890)					S12193000
X-96	エアホース 4X2.5-20 (L=1060) AIR TUBE 4X2.5-20 (L=1060)					S12196000
X-97	エアホース 4X2.5-21 (L=1090) AIR TUBE 4X2.5-21 (L=1090)					S12197000
Y-15	フットスイッチハーネス FOOT SWITCH HARNESS	S11700000	←	←	←	←
Y-52-2	ノーヒューズブレーカー-B (10A) NO FUSE BREAKER (B)(10A)	152661100	←	←	←	←
B1-5B	スポンジ 3X170X500 SPONGE 3X170X500					S12249000
B1-59	アテイタ CAUL	S12250009	←	←	←	←
B1-70	サラネジ 4X8 SCREW 4X8	003400804	←	←	←	←
B1-111	+トラスコ 4X8 SCREW 4X8	008400806	←	←	←	←
B1-112	+トラスコ 4X6 SCREW 4X6	008400604	←	←	←	←

REF.NO	品名 PARTS	サブクラス SUB CLASS	30121 200V,50-60HZ FOR DOMESTIC	32111 200V,50-60HZ FOR DOMESTIC	32121 200V,50-60HZ FOR DOMESTIC	40111 200V,50-60HZ FOR DOMESTIC	40121 200V,50-60HZ FOR DOMESTIC
P-12B	スタツカー(WORK)					S14461009	←
X-7	バルブ14ク VALVE 14 ASSEMBLY		S1772B001	←	←	←	←
X-57	エアホース 4X2.5-15 (L=770) AIR TUBE 4X2.5-15 (L=770)		S12191000	←	←	-----	-----
X-79	バキユームソウチクミ VACUUM EQUIPMENT ASSEMBLY			S12496001	←	-----	-----
X-86	バキユームウラフタ		S15544001	-----	-----	S15544001	←
X-87	サラネジ" 4.37		100032003	-----	-----	100032003	←
X-93	バルブ2クミ		-----	-----	-----	-----	-----
X-94	エアホース 4X2.5-15 (L=770) AIR TUBE 4X2.5-15 (L=770)		S12191000	←	←	←	←
X-95	エアホース 4X2.5-17 (L=890) AIR TUBE 4X2.5-17 (L=890)		S12193000	←	←	←	←
X-96	エアホース 4X2.5-20 (L=1060) AIR TUBE 4X2.5-20 (L=1060)		S12196000	←	←	←	←
X-97	エアホース 4X2.5-21 (L=1090) AIR TUBE 4X2.5-21 (L=1090)		S12197000	←	←	←	←
Y-15	フツトスイッチハーネス FOT SWITCH HARNESS		S11700000	←	←	←	←
Y-52-2	ノーヒューズブレーカーB (10A) NO FUSE BREAKER (B)(10A)		152661100	←	←	←	←
B1-58	スポンジ" 3X170X500 SPONGE 3X170X500		S12249000	←	←	-----	-----
B1-59	アテイタ CAUL		S12250009	←	←	-----	-----
B1-70	サラネジ" 4X8 SCREW 4X8		003400804	←	←	-----	-----
B1-111	+トラスコ 4X8 SCREW 4X8		008400806	←	←	-----	-----
B1-112	+トラスコ 4X6 SCREW 4X6		008400604	←	←	-----	-----

REF.NO.	サブクラス SUB CLASS ヒンメイ PARTS	31102	31103	31104	31202	31203,31204
		220V,50-60HZ FOR EXPORT	380V,50-60HZ FOR EXPORT	415V,50-60HZ FOR EXPORT	220V,50-60HZ 50-60HZ FOR EXPORT	380,415V FOR EXPORT
X-7	バルブ14ク VALVE 14 ASSEMBLY	S17728001	←	←	←	←
X-57	エアホース 4X2.5 15 (L 770) AIR TUBE 4X2.5 15 (L 770)	S12191000	←	←	←	←
X-79	バキュームソウチク VACUUM EQUIPMENT ASSEMBLY	S12496001	←	←	←	←
X-94	エアホース 4X2.5-15 (L 770) AIR TUBE 4X2.5 15 (L 770)	S12191000	←	←	←	←
X-95	エアホース 4X2.5-17 (L 890) AIR TUBE 4X2.5 17 (L 890)	S12193000	←	←	←	←
X-96	エアホース 4X2.5-20 (L 1060) AIR TUBE 4X2.5-20 (L 1060)	S12196000	←	←	←	←
X-97	エアホース 4X2.5-21 (L 1090) AIR TUBE 4X2.5-21 (L 1090)	S12197000	←	←	←	←
Y-15	フットスイッチハーネス FOOT SWITCH HARNESS	S11700000	←	←	-----	-----
Y-52-1	----- NO FUSE BREAKER (5A)	-----	S05071100	←	-----	S05071100
Y-52-2	ノーヒューズブレーカー-B (10A) NO FUSE BREAKER (B)(10A)	152661100	-----	-----	152661100	-----
Y-124	----- HAND SWITCH ASSEMBLY	-----	-----	-----	S12467001	←
Y-125	----- LIGHT HARNESS	-----	S11707000	←	←	←
Y-126	----- TERMINAL HARNESS (2P)	-----	S11708000	←	←	←
Y-127	----- FUSE (0.5A)	-----	151827000	←	←	←
Y-128	----- BOLT 4X12	-----	018401222	←	←	←
Y-129	----- SPRING WASHER 2-4	-----	028040242	←	←	←
B1-58	スポンジ 3X170X500 SPONGE 3X170X500	S12249000	←	←	←	←
B1-59	アテイタ CAUL	S12250009	←	←	←	←

REF.NO.	サブクラス SUB CLASS	31102	31103	31104	31202	31203,31204
		220V,50-60HZ	380V,50-60HZ	415V,50-60HZ	220V,50-60HZ 50-60HZ FOR EXPORT	380,415V FOR EXPORT
	品名 PARTS	FOR EXPORT	FOR EXPORT	FOR EXPORT	FOR EXPORT	FOR EXPORT
B1-70	ワナネジ 4X8 SCREW 4X8	003400804	←	←	←	←
B1-111	ワナネジ 4X8 SCREW 4X8	008400806	←	←	←	←
B1-112	ワナネジ 4X6 SCREW 4X6	008400604	←	←	←	←

索引/INDEX/VERZEICHNIS/
INDEX/INDICE

CODE	REF.NO.	PAGE
S00337001	J - 1	16
S00480000	K - 11	18
	L - 10	18
	R - 49	36
	T - 77	90
S00879001	C - 8	6
S00966000	Z - 9	124
S01005000	Z - 6-2-4	124
S01040001	F - 34	10
S01208000	X - 79 1-2	102
S01234000	B - 5	4
	F - 30	10
	F - 7	10
S01522000	X - 1-2-7	96
	X - 1-3-8	96
	X - 18-2	96
	X - 78-1-3	102
	X - 79-1-3	102
S01542000	X - 1-2-8	96
	X - 1-3-7	96
	X - 7-7	96
	X - 93-5	102
S01824000	C1 - 1-2	116
S01998001	C - 14	6
S02525001	B - 9	4
S02526000	B - 9-1	4
S02527001	B - 12	4
S02546201	C - 15	6
S02551001	C - 38	6
S02611001	H - 1-1	14
S02612001	H - 1-2	14
S02614109	H - 10	14
S02617001	H - 14	14
S02620001	H - 17-4	14
S02624001	H - 17-8	14
S02637001	J - 4	16
	Z - 12	124
S02643001	J - 6	16
S02645001	J - 13	16
	Z - 13	124
S02647001	J - 22	16
S02648001	J - 23	16
S02652001	J - 39	16
S02654001	J - 40	16
S02655001	J - 43	16
S02657001	A - 39	2
	J - 48	16
S02658001	K - 1	18
S02736001	B - 29-2	4
S02738009	D1- 6-1	116
S02739000	D1- 6-3	116
S02740000	D1- 6-2	116
S02747001	Z - 6-12	124
S02763202	Z - 6	124
S02777001	Z - 6-2	124
S02778002	Z - 6-6	124
S02780001	Z - 6-7	124
S02786002	Z - 6-11	124
S02915000	Y - 90	108
S02939009	D1- 1	116
S03245001	F - 24	10
S03246001	F - 24-4	10
S03254001	H - 17-1	14
S03670001	K - 9	18
S04159000	A1- 20	110
	P - 128-63	30
	S - 1-1-42	38

CODE	REF.NO.	PAGE
S04159000	S - 12-1-42	56
	S - 12-3-60	62
	S - 13-1-42	64
	S - 13-3-60	70
	S - 14-1-42	72
	S - 14-3-60	78
	S - 15-1-41	80
	S - 15-3-60	86
	S - 2-1-42	42
	S - 3-1-42	46
	S - 4-1-41	50
	U - 4	92
	X - 71	98
	Y - 124-6	108
	Y - 92	108
S04488000	Y - 122	108
S04577000	X - 7-8	96
S04587000	D3- 15-16	120
	Q - 80	34
	S - 13-1-48	64
	S - 14-1-47	72
	S - 15-1-47	80
	S - 2-1-48	42
	S - 3-1-47	46
	S - 4-1-47	50
S04782000	T - 9	88
S04891000	X - 85	100
S04896000	X - 14-2	96
	X - 79-9	102
S04897000	S - 13-1-47	64
	S - 14-1-46	72
	S - 15-1-46	80
	S - 2-1-47	42
	S - 3-1-46	46
	S - 4-1-46	50
	X - 1-2-9	96
	X - 1-3-3	96
	X - 7-5	96
	X - 93-3	102
S04905000	P - 128-23-2	28
	S - 1-1-53-2	38
	S - 12-1-53-2	56
	S - 13-1-55-2	66
	S - 14-1-55-2	74
	S - 15-1-59-2	82
	S - 2-1-55-2	44
	S - 3-1-55-2	48
	S - 4-1-59-2	52
	X - 1-7	96
	X - 24-2	98
	X - 92-3	98
S04909000	C - 29-3	6
	P - 14-2	22
	Q - 13-2	32
	X - 1-3-6	96
S04910000	C - 29-2	6
	T - 14-2	88
S04993000	Y - 2-14	104
S05035000	Y - 18-1	106
S05068000	Y - 1-3	104
S05071100	Y - 52-1	106
S06143000	Y - 63	106
S06550001	C1 - 1-1	116
S06551101	C1 - 1-1-1	116
S06552000	C1 - 1-1-2	116
S06857000	X - 83	100
S06858000	X - 83-1	100

CODE	REF.NO.	PAGE
S06859000	X - 83 2	100
S07229101	G - 4	12
S07467001	K - 12	18
S07469001	G - 58	12
S07478000	G - 29	12
	G - 46	12
S07901000	H - 19	14
S07972001	H - 5	14
S08017000	A1 - 14-1-1	110
	A1 - 18-4-1 1	110
S08119000	Y - 10-1	106
	Y - 21-1	106
S08137000	A1 - 19	110
S08367000	A1 - 14-1	110
	A1 - 18-4-1	110
S09027001	P - 98	24
S09141000	Y - 17	106
S09142000	Y - 138	108
S09197000	A - 35	2
S09231000	X - 14-1	96
S09989000	D2- 10-3	118
	D2- 11-3	118
	D2- 12-3	118
	D2- 13-3	118
	D2- 14-3	118
	D2- 2-3	118
	D2- 3-3	118
	D2- 4-3	118
	D2- 5-3	118
	D2- 7-3	118
	D2- 8-3	118
	D2- 9-3	118
	Z - 27	126
S10243000	R - 47	36
S10476001	D1- 6-4	116
S11182009	H - 17-9	14
S11183009	H - 17-9-1	14
S11184009	H - 17-9-1-1	14
S11426000	P - 107-2	26
	P - 115-2	26
	P - 128-17-4	28
	P - 38-3	22
	P - 47-3	24
	T - 27-2	88
	T - 33-2	88
	T - 36-4	88
	T - 37-4	88
S11433000	Q - 29-2	32
	S - 1-1-13-2	38
	S - 1-1-39-2	38
	S - 12-1-13-2	56
	S - 12-1-39-2	56
	S - 12-3-11-2	60
	S - 12-3-22-2	60
	S - 13-1-13-2	64
	S - 13-1-39-2	64
	S - 13-3-11-2	68
	S - 13-3-22-2	68
	S - 14-1-13-2	72
	S - 14-1-39-2	72
	S - 14-3-11-2	76
	S - 14-3-22-2	76
	S - 15-1-13-2	80
	S - 15-1-38-2	80
	S - 15-3-11-2	84
	S - 15-3-22-2	84
	S - 2-1-13-2	42

CODE	REF.NO.	PAGE
S11433000	S - 2-1-39-2	42
	S - 3-1-13-2	46
	S - 3-1-39-2	46
	S - 4-1-13-2	50
	S - 4-1-38-2	50
	T - 56-2	90
	X - 88-2	98
S11688100	Y - 4	106
S11689000	Y - 5	106
S11690000	Y - 6	106
S11691000	Y - 53	106
S11692000	Y - 57	106
S11693000	Y - 7	106
S11694000	Y - 8	106
S11695000	Y - 9	106
S11696000	Y - 10	106
S11697000	Y - 11	106
S11698000	Y - 12	106
S11700000	Y - 15	106
S11701000	Y - 16	106
S11702000	Y - 3	106
S11703000	Y - 14	106
S11705000	Y - 1-10-3	104
	Z - 23	126
S11706000	Y - 2-21	104
S11707000	Y - 125	104
S11708000	Y - 126	104
S11711000	Y - 21	106
S11712000	Y - 19	106
S11714300	L - 2	18
S11715100	Y - 18	106
S11716000	Y - 23	106
S11717000	Y - 32	106
S11718000	Y - 24	106
S11719000	Y - 25	106
S11720000	Y - 26	106
S11721000	Y - 27	106
S11722000	Y - 28	106
S11723000	Y - 29	106
S11724000	Y - 30	106
S11725000	Y - 31	106
S11726000	Y - 33	106
S11727000	Y - 34	106
S11728000	Y - 59	106
S11729000	Y - 35	106
S11730000	Y - 36	106
S11731000	Y - 37	106
S11732000	Y - 38	106
S11733000	Y - 39	106
S11734000	Y - 1-10-1	104
	Z - 16	124
S11737100	L - 1	18
S11738100	Y - 42	106
S11739000	Y - 44	106
S11740000	Y - 43	106
S11748000	Y - 2-11	104
S11749000	Y - 2-8	104
S11750000	Y - 2-9	104
S11751000	Y - 2-10	104
S11752000	Y - 2-7	104
S11753000	Y - 2-6	104
S11754000	Y - 2-5	104
S11755000	Y - 2-4	104
S11756100	Y - 2-3	104
S11757000	Y - 2-13	104
S11761000	Y - 2-20	104
S11762000	Y - 87	108

CODE	REF.NO.	PAGE
S11763000	Y - 86	108
S11764000	Y - 85	108
S11783000	Y - 1 7	104
S11798000	Y - 1-13	104
S11806000	Y - 1-1	104
S11807000	Y - 1-2	104
S11808000	Y - 1 9	104
S11809000	Y - 1 8	104
S11810000	Y - 1-11 3	104
S11811000	Y - 1-11-1	104
S11812000	Y - 1-11-2	104
S11813000	Y - 1-4	104
S11814000	Y - 1-5	104
S11815000	Y - 1-12	104
S11816000	Y - 60	106
S11817000	Y - 82	108
S11823101	Y - 1	104
S11825000	V - 2	92
S11826000	Y - 2-1	104
S11827000	Y - 2-2	104
S11828000	L - 6-1	18
S11830300	L - 2-1	18
S11831200	L - 2-2	18
S11835000	Y - 1-6	104
S11837100	D3- 15-55	120
	V - 4	92
S11839000	Y - 91	108
S11840000	Y - 69	108
S11841000	Y - 70	108
S11842000	Y - 71	108
S11848000	U - 18	92
	Y - 79	108
S11854009	A - 2	2
S11855001	A - 13	2
S11856001	A - 15	2
S11857000	A - 17	2
S11858001	A - 19	2
S11860009	A - 28	2
S11862001	B - 1	4
S11863001	B - 6	4
S11864010	B - 20-1	4
	Z - 4-1	124
S11864012	B - 20-2	4
	Z - 4-2	124
S11864016	B - 20-3	4
	Z - 4-3	124
S11865001	B - 26	4
S11866000	B - 28	4
S11867001	B - 29-1	4
S11871001	C - 10	6
S11872001	C - 11	6
S11873001	C - 20	6
S11874001	C - 22	6
S11875001	C - 24	6
S11876001	C - 25	6
S11877001	C - 27	6
S11878000	C - 29	6
S11879000	C - 29-1	6
S11880000	C - 30	6
	T - 40	88
	T - 47	90
S11881001	C - 31	6
S11882009	C - 33	6
S11883001	C - 39	6
S11884001	D - 1	8
S11885001	D - 4	8
S11886000	D - 7	8

CODE	REF.NO.	PAGE
S11887101	E - 1	8
S11888001	E - 2	8
S11889001	E - 6-1	8
	Z - 10-1	124
S11890001	E - 9	8
S11891001	F - 1	10
S11892001	F - 3	10
S11893001	F - 9	10
S11894001	F - 12	10
S11895001	F - 14	10
S11896001	F - 15	10
S11898000	F - 18	10
S11899000	F - 19	10
S11900001	F - 31	10
S11901000	G - 1	12
S11902000	G - 3	12
S11903000	G - 10	12
S11906000	G - 11	12
S11907009	G - 15	12
S11908000	G - 17	12
S11909000	G - 20	12
	G - 51	12
S11910000	G - 21	12
S11911009	G - 26	12
S11912001	G - 30	12
S11913001	G - 34	12
S11914000	G - 55	12
S11915000	G - 43	12
S11916001	G - 44	12
S11917001	G - 47	12
S11918000	G - 50	12
S11919000	G - 52	12
S11920001	G - 56	12
S11921000	B - 2	4
	F - 4	10
S11922000	B - 3	4
S11923000	F - 5	10
S11924000	F - 28	10
S11925009	H - 12	14
S11926001	J - 12	16
S11927009	J - 36	16
S11928009	J - 36-1	16
S11929001	J - 45	16
S11930001	J - 46	16
S11931001	K - 2	18
S11932001	K - 4	18
S11933001	K - 7	18
S11934009	M - 1	20
S11935009	M - 4	20
S11936001	M - 7	20
S11937001	M - 9	20
S11943009	M - 13	20
S11944000	G - 59	12
S11945000	G - 24	12
S11946000	U - 2	92
S11947000	U - 3	92
S11949000	U - 5	92
S11950000	B1- 2	112
S11951001	Y - 124-5	108
S11952000	X - 78-1-1	102
S11953000	X - 78-1	102
S11954000	N - 13	20
S11955000	N - 14	20
S11956000	X - 78-5	102
S11957000	X - 78-6	102
S11958000	X - 78-7	102
S11959001	Z - 24	126

CODE	REF.NO.	PAGE
S11961001	N 1	20
S11962001	N 2	20
S11963001	N 3	20
S11964001	N 4	20
S11966001	N 9	20
S11967001	N 10	20
S11968009	P 1	22
S11969000	P 5	22
S11970009	P 8	22
S11971009	P 11	22
S11972001	P 13	22
S11973000	P 14	22
S11974000	P 14-1	22
S11975000	P 15	22
S11976000	P 17	22
S11977001	P 18	22
S11978009	P 20	22
S11979000	P 21	22
S11980001	P 22	22
S11985001	P 34	22
S11986000	P 38	22
S11987000	P 38-1	22
S11988000	P 38-2	22
	T 39-3	88
S11989009	P 39	22
S11990001	P 42	22
S11991009	P 43	24
S11992000	P 47	24
S11993000	P 47-1	24
S11994000	P 128-17-3	28
	P 47-2	24
	T 36-3	88
	T 37-3	88
S11995009	P 48	24
S11996000	P 52	24
S11997001	P 55	24
S11998009	P 56	24
S11999001	P 59	24
S12000009	P 66	26
S12001001	P 70	26
S12002000	P 73	24
S12003000	P 74	24
S12004000	P 75	24
S12005001	P 76	24
S12006000	P 78	24
S12007000	P 79	24
S12008000	P 81	24
S12009000	P 81-1	24
S12010000	P 84	24
S12011001	P 85	24
S12012000	P 87	24
S12013000	P 89	24
S12014000	P 90	24
S12015000	P 91	24
S12019001	P 96	24
S12020001	P 99	24
S12021001	P 102	24
S12022001	P 105	26
S12023001	P 106	26
S12024000	P 107	26
S12025000	P 107-1	26
S12026001	P 110	26
S12027109	W 1-1	94
S12029109	P 112	26
S12030000	P 115	26
S12031000	P 115-1	26
S12033009	P 118	26

CODE	REF.NO.	PAGE
S12035000	D3- 15-2	120
	Q - 2	32
S12036000	D3- 15-3	120
	Q - 3	32
S12038001	Q - 53	32
	Q - 9	32
S12039001	Q - 10	32
	Q - 46	32
S12042009	P - 63	24
S12043000	U - 1	92
S12044000	Q - 17	32
S12045000	D3- 15-8	120
	Q - 18	32
S12050001	Q - 26	32
S12051000	Q - 29	32
	T - 56	90
S12052000	Q - 29-1	32
	T - 27-1	88
	T - 33-1	88
	T - 56-1	90
S12053000	Q - 30	32
	S - 12-3-23	60
	S - 13-3-23	68
	S - 14-3-23	76
	S - 15-3-23	84
	T - 28	88
	T - 34	88
	T - 57	90
S12054000	Q - 33	32
	Q - 55	32
S12056001	Q - 43	32
S12057100	P - 128-64	30
S12059009	Q - 61	32
S12060001	Q - 64	34
	Q - 69	34
S12061009	Q - 66	34
S12062009	Q - 75	34
S12063009	R - 1	36
S12064000	R - 4	36
S12065000	R - 5	36
S12066000	R - 6	36
S12067000	R - 7	36
S12068001	R - 8	36
S12069000	R - 9	36
S12070000	R - 11	36
S12071009	R - 13	36
S12072009	R - 14	36
S12073000	R - 17	36
S12074000	R - 19	36
S12075009	R - 21	36
S12076000	R - 22	36
S12077000	R - 23	36
S12078000	P - 128-7	28
	R - 24	36
S12079000	R - 25	36
S12080000	R - 26	36
S12081000	R - 27	36
S12082000	R - 32	36
S12084001	R - 38	36
S12085001	R - 39	36
S12086001	S - 1-1-1	38
	S - 12-1-1	56
	S - 13-1-1	64
	S - 14-1-1	72
	S - 15-1-1	80
	S - 2-1-1	42
	S - 3-1-1	46

CODE	REF.NO.	PAGE	
S12086001	S - 4-1-1	50	
	S - 1-1-2	38	
S12087001	S - 12-1-2	56	
	S - 13-1-2	64	
S12088009	S - 14-1-2	72	
	S - 15-1-2	80	
	S - 2-1-2	42	
	S - 3-1-2	46	
	S - 4-1-2	50	
	S - 1-1-9	38	
	S - 12-1-9	56	
	S - 13-1-9	64	
	S - 14-1-9	72	
	S - 15-1-9	80	
	S - 2-1-9	42	
	S - 3-1-9	46	
	S - 4-1-9	50	
	S12089009	S - 1-1-10	38
		S - 12-1-10	56
S - 13-1-10		64	
S - 14-1-10		72	
S - 15-1-10		80	
S - 2-1-10		42	
S - 3-1-10		46	
S - 4-1-10		50	
S12090000		S - 1-1-13	38
		S - 12-1-13	56
	S - 13-1-13	64	
	S - 14-1-13	72	
	S - 15-1-13	80	
	S - 2-1-13	42	
	S - 3-1-13	46	
	S - 4-1-13	50	
	S12091000	S - 1-1-13-1	38
		S - 12-1-13-1	56
S - 13-1-13-1		64	
S - 14-1-13-1		72	
S - 15-1-13-1		80	
S - 2-1-13-1		42	
S - 3-1-13-1		46	
S - 4-1-13-1		50	
S12092000		S - 1-1-14	38
		S - 12-1-14	56
	S - 13-1-14	64	
	S - 14-1-14	72	
	S - 15-1-14	80	
	S - 2-1-14	42	
	S - 3-1-14	46	
	S - 4-1-14	50	
	S12093001	S - 1-1-16	38
		S - 12-1-16	56
S - 13-1-16		64	
S - 14-1-16		72	
S - 15-1-16		80	
S - 2-1-16		42	
S - 3-1-16		46	
S - 4-1-16		50	
S12094001		S - 1-1-17	38
		S - 12-1-17	56
	S - 13-1-17	64	
	S - 14-1-17	72	
	S - 15-1-17	80	
	S - 2-1-17	42	
	S - 3-1-17	46	
	S - 4-1-17	50	
	S12095001	S - 1-1-18	38
		S - 12-1-18	56

CODE	REF.NO.	PAGE
S12095001	S - 13-1-18	64
	S - 14-1-18	72
	S - 15-1-18	80
	S - 2-1-18	42
	S - 3-1-18	46
S12096001	S - 4-1-18	50
	S - 1-1-19	38
	S - 12-1-19	56
	S - 13-1-19	64
	S - 14-1-19	72
	S - 15-1-19	80
	S - 2-1-19	42
	S - 3-1-19	46
	S - 4-1-19	50
	S12097001	S - 1-1-21
S - 12-1-21		56
S - 13-1-21		64
S - 14-1-21		72
S - 15-1-21		80
S12098001	S - 2-1-21	42
	S - 3-1-21	46
	S - 4-1-21	50
	S - 1-1-22	38
	S - 12-1-22	56
	S - 13-1-22	64
	S - 14-1-22	72
	S - 15-1-22	80
	S - 2-1-22	42
	S - 3-1-22	46
S12099001	S - 4-1-22	50
	S - 1-1-24	38
	S - 12-1-24	56
	S - 13-1-24	64
	S - 14-1-24	72
	S - 15-1-24	80
	S - 2-1-24	42
	S - 3-1-24	46
	S - 4-1-24	50
	S12102000	S - 1-1-39
S - 12-1-39		56
S - 12-3-11		60
S - 13-1-39		64
S - 13-3-11		68
S - 14-1-39		72
S - 14-3-11		76
S - 15-1-38		80
S - 15-3-11		84
S - 2-1-39		42
S12103000	S - 3-1-39	46
	S - 4-1-38	50
	S - 1-1-39-1	38
	S - 12-1-39-1	56
	S - 12-3-11-1	60
	S - 12-3-12-1	60
	S - 13-1-39-1	64
	S - 13-3-11-1	68
	S - 13-3-12-1	68
	S - 14-1-39-1	72
S12104000	S - 14-3-11-1	76
	S - 14-3-12-1	76
	S - 15-1-38-1	80
	S - 15-3-11-1	84
	S - 15-3-12-1	84
	S - 2-1-39-1	42
	S - 3-1-39-1	46
	S - 4-1-38-1	50
	P - 128-57	30

CODE	REF.NO.	PAGE
S12104000	S 1 1 44	38
	S 12-1-44	56
	S 13 1-44	64
	S - 14 1-44	72
	S 15-1-43	80
	S 2-1 44	42
	S - 3 1 44	46
	S 4 1 43	50
	X 63	98
	S 1 2-10	40
S12105000	S - 12-2-10	58
	S 13-2-10	66
	S - 14-2-10	74
	S - 15-2-10	82
	S 2-2-10	44
	S 3-2-10	48
	S 4-2-10	52
	S - 1-1-31	38
S12106000	S - 12-1-31	56
	S - 13-1-31	64
	S - 14-1-31	72
	S - 15-1-31	80
	S - 2-1-31	42
	S - 3-1-31	46
	S - 4-1-31	50
	S - 1-2-1	40
S12107001	S - 12-2-1	58
	S - 13-2-1	66
	S - 14-2-1	74
	S - 15-2-1	82
	S - 2-2-1	44
	S - 3-2-1	48
	S - 4-2-1	52
	S - 1-2-6	40
S12108001	S - 12-2-6	58
	S - 13-2-6	66
	S - 14-2-6	74
	S - 15-2-6	82
	S - 2-2-6	44
	S - 3-2-6	48
	S - 4-2-6	52
	S - 1-2-7	40
S12109000	S - 12-2-7	58
	S - 13-2-7	66
	S - 14-2-7	74
	S - 15-2-7	82
	S - 2-2-7	44
	S - 3-2-7	48
	S - 4-2-7	52
	S - 1-3-1	40
S12110001	S - 12-3-68	62
	S - 13-3-68	70
	S - 14-3-68	78
	S - 15-3-68	86
	S - 2-3-1	44
	S - 3-3-1	48
	S - 4-3-1	52
	S - 1-5	40
S12111001	S - 12-5	62
	S - 13-5	70
	S - 14-5	78
	S - 15-5	86
	S - 2-5	44
	S - 3-5	48
	S - 4-5	52
	S - 1-6	40
S12112001	S - 12-6	62

CODE	REF.NO.	PAGE
S12112001	S - 13-6	70
	S - 14-6	78
	S - 15-6	86
	S - 2-6	44
	S - 3-6	48
	S - 4-6	52
S12113001	S - 1-4-1	40
	S - 12-4-1	58
	S - 13-4-1	66
	S - 14-4-1	74
	S - 15-4-1	82
	S - 2-4-1	44
S12114001	S - 3-4-1	48
	S - 4-4-1	52
	S - 1-4-5	40
	S - 12-4-5	58
	S - 13-4-5	66
	S - 14-4-5	74
S12116000	S - 15-4-5	82
	S - 2-4-5	44
	S - 3-4-5	48
	S - 4-4-5	52
	Z - 20	126
	S - 1-4-14	40
S12117000	S - 12-4-14	58
	S - 13-4-15	66
	S - 14-4-15	74
	S - 15-4-14	82
	S - 2-4-15	44
	S - 3-4-15	48
S12119001	S - 4-4-14	52
	Z - 21	126
	T - 2	88
	T - 8	88
	T - 14	88
	T - 14-1	88
S12123000	T - 15	88
	T - 16	88
	T - 18	88
	T - 21	88
	T - 22	88
	T - 23	88
S12125000	T - 24	88
	T - 25	88
	T - 27	88
	T - 33	88
	T - 30	88
	T - 31	88
S12126000	T - 36	88
	P - 128-17-2	28
	T - 36-2	88
	T - 37-2	88
	T - 36-1	88
	T - 37	88
S12127109	T - 37-1	88
	T - 39	88
	T - 39-2	88
	T - 39-1	88
	T - 43	88
	T - 43-1	88
S12128101	P - 81-2	24
	S - 12-3-12-2	60
	S - 12-3-21-2	60
	S - 12-3-39-2	60
	S - 12-3-48-2	60
	S - 13-3-12-2	68
S12129000	S - 13-3-21-2	68

CODE	REF.NO.	PAGE
S12150000	S 13 3 39-2	68
	S 13-3-48-2	68
	S 14 3-12-2	76
	S 14 3-21-2	76
	S 14 3-39-2	76
	S 14 3-48 2	76
	S 15 3-12-2	84
	S 15 3-21-2	84
	S 15 3 39-2	84
	S 15 3-48-2	84
	T 43-2	88
	X 88-3	98
S12151009	T 48	90
S12152001	T 49	90
S12153001	T 50	90
S12154000	T 53	90
S12155101	X 1-1	96
S12157000	X 7-1	96
S12158000	X 1-2-2	96
S12159000	X 7-4	96
S12159001	X 1-2-5	96
S12160000	X 1-2-3	96
	X 7-2	96
S12161000	X 1-2-4	96
	X 1-3-2	96
	X 7-3	96
	X 93-2	102
S12164000	X 1-3-4	96
S12165000	X 1-6	96
S12166000	X 14	96
S12167000	X 24	98
S12168000	X 18	96
S12169000	X 18-1	96
S12170000	X 18-3	96
S12171001	X 19	96
S12172000	X 20	96
S12173000	X 24-1	98
S12174000	X 24-3	98
S12175000	X 29	98
	X 79-10	102
S12176000	X 32	98
S12178000	X 36	98
S12179000	X 37	98
S12181000	X 39	98
S12182000	X 40	98
S12183000	P 128-56	30
	X 41	98
S12184000	X 42	98
S12185000	X 43	98
S12186000	X 44	98
S12187000	X 45	98
S12188000	X 46	98
S12189000	X 47	98
S12190000	X 48	98
S12191000	X 49	98
	X 57	98
	X 79-13	102
	X 94	98
S12192000	X 50	98
S12193000	X 51	98
	X 95	100
S12194000	X 52	98
S12195000	P 128-55	30
	X 53	98
S12196000	X 54	98
	X 96	100
S12197000	X 55	98

CODE	REF.NO.	PAGE
S12197000	X 97	100
S12198000	X 56	98
S12201000	X 59	98
S12205000	S 1-1-43	38
	S 12-1-43	56
	S 13-1-43	64
	S 14-1-43	72
	S 15-1-42	80
	S 2-1-43	42
	S 3-1-43	46
	S 4-1-42	50
S12206000	X 66	98
	X 78-8	102
	X 79-11	102
S12207000	X 67	98
	X 78-10	102
	X 79-15	102
S12208000	X 68	98
S12209000	X 69	98
	X 79-4	102
S12210000	X 70	98
	X 79-16	102
S12211000	X 72	98
S12212000	X 73	98
S12213000	X 74	98
S12214000	S 1-1-30	38
	S 12-1-30	56
	S 13-1-30	64
	S 14-1-30	72
	S 15-1-30	80
	S 2-1-30	42
	S 3-1-30	46
	S 4-1-30	50
	X 75	98
S12215000	X 76	98
	Y 83	108
S12216001	A1 1	110
S12217001	A1 4	110
S12219001	A1 10	110
S12222009	C1 1	116
S12225000	B1 3	112
S12226001	B1 4	112
S12227001	B1 5	112
S12229001	B1 7	112
S12230001	B1 10	112
S12231001	B1 11	112
S12232001	B1 14	112
S12233001	B1 17	112
S12234000	B1 20	112
S12235009	B1 23	112
S12236109	B1 26	112
S12239009	B1 35	112
S12241009	B1 42	112
S12243001	B1 46	112
S12244001	B1 47	112
S12246001	B1 51	112
S12247001	B1 52	112
S12249000	B1 58	112
S12250009	B1 59	112
S12251009	B1 60	112
S12252009	B1 61	112
S12253009	B1 62	112
S12257109	B1 71	114
	D3 15-37	120
S12258109	B1 72	114
	D3 15-38	120
S12259009	B1 75	114

CODE	REF.NO.	PAGE
S12259009	D3 - 15-39	120
S12260009	B1 - 78	114
S12261001	B1 - 81	114
S12262001	B1 - 82	114
S12263001	B1 - 84	114
S12264001	B1 - 85	114
S12265001	B1 - 87	114
S12268000	Q - 58	32
S12269000	Q - 59	32
S12270000	Q - 60	32
S12271000	T - 38	88
S12272001	D2 - 2	118
S12273001	D2 - 3	118
S12274001	D2 - 4	118
S12276000	P - 116	26
S12277000	P - 125	26
S12278000	S - 1-2-11	40
	S - 12-2-11	58
	S - 13-2-11	66
	S - 14-2-11	74
	S - 15-2-11	82
	S - 2-2-11	44
	S - 3-2-11	48
	S - 4-2-11	52
S12279000	S - 1-3-7	40
	S - 12-3-73	62
	S - 13-3-73	70
	S - 14-3-73	78
	S - 15-3-73	86
	S - 2-3-7	44
	S - 3-3-7	48
	S - 4-3-7	52
S12280100	B1 - 89	114
S12281001	D2 - 5	118
S12283---	S - 1	38
S12283001	D2 - 2-1	118
	D2 - 7-1	118
S12284---	S - 1-1	38
	S - 12-1	56
S12285---	S - 1-1-32	38
	S - 12-1-32	56
S12286---	S - 1-1-33	38
	S - 12-1-33	56
S12287---	S - 1-1-34	38
	S - 12-1-34	56
S12288---	S - 1-1-35	38
	S - 12-1-35	56
S12289---	S - 1-1-45	38
	S - 12-1-45	56
S12291001	S - 1-1-47	38
	S - 12-1-47	56
	S - 13-1-49	64
	S - 14-1-48	72
	S - 15-1-53	80
	S - 2-1-49	42
	S - 3-1-48	46
	S - 4-1-53	50
S12292---	S - 1-2	40
	S - 12-2	58
S12293---	S - 1-2-9	40
	S - 12-2-9	58
S12294001	S - 1-1-48	38
	S - 12-1-48	56
	S - 13-1-50	64
	S - 14-1-49	72
	S - 15-1-54	80
	S - 2-1-50	42

CODE	REF.NO.	PAGE
S12294001	S - 3-1-49	46
	S - 4-1-54	50
S12295---	S - 1-3	40
S12296---	S - 1-3-5	40
S12297000	S - 1-1-46	38
	S - 12-1-46	56
	S - 13-1-46	64
	S - 14-1-54	72
	S - 15-1-45	80
	S - 2-1-46	42
	S - 3-1-54	46
	S - 4-1-45	50
S12298000	S - 1-3-6	40
	S - 12-3-72	62
	S - 13-3-72	70
	S - 14-3-72	78
	S - 15-3-72	86
	S - 2-3-6	44
	S - 3-3-6	48
	S - 4-3-6	52
	Z - 19	126
S12299---	S - 1-4	40
	S - 12-4	58
S12300---	S - 1-4-7	40
	S - 12-4-7	58
S12301---	S - 1-4-8	40
	S - 12-4-8	58
S12302---	S - 1-4-9	40
	S - 12-4-9	58
S12303---	S - 1-4-10	40
	S - 12-4-10	58
S12305---	S - 2	42
S12305001	D2 - 3-1	118
	D2 - 8-1	118
S12306---	S - 13-1	64
	S - 2-1	42
S12307---	S - 13-1-32	64
	S - 2-1-32	42
S12308---	S - 13-1-33	64
	S - 2-1-33	42
S12309---	S - 13-1-34	64
	S - 2-1-34	42
S12310---	S - 13-1-35	64
	S - 2-1-35	42
S12311---	S - 13-1-45	64
	S - 2-1-45	42
S12312---	S - 2-2	44
S12312000	S - 13-2	66
S12313---	S - 13-2-9	66
	S - 2-2-9	44
S12314---	S - 2-3	44
S12315---	S - 2-3-5	44
S12316---	S - 13-4	66
	S - 2-4	44
S12317---	S - 13-4-7	66
	S - 2-4-7	44
S12318---	S - 13-4-8	66
	S - 2-4-8	44
S12319---	S - 13-4-9	66
	S - 2-4-9	44
S12320---	S - 13-4-10	66
	S - 2-4-10	44
S12321---	S - 13-4-11	66
	S - 2-4-11	44
S12323---	S - 3	46
S12323001	D2 - 4-1	118
	D2 - 9-1	118

CODE	REF.NO.	PAGE
S12324	S - 14 1	72
	S - 3-1	46
S12325	S - 14-1-32	72
	S - 3 1-32	46
S12326	S - 14-1-33	72
	S - 3-1-33	46
S12327	S - 14-1-34	72
	S - 3-1-34	46
S12328	S - 14-1-35	72
	S - 3-1-35	46
S12329	S - 14-1-45	72
	S - 3-1-45	46
S12330	S - 14-2	74
	S - 3-2	48
S12331	S - 14-2-9	74
	S - 3-2-9	48
S12332	S - 3-3	48
S12333	S - 3-3-5	48
S12334	S - 14-4	74
	S - 3-4	48
S12335	S - 14-4-7	74
	S - 3-4-7	48
S12336	S - 14-4-8	74
	S - 3-4-8	48
S12337	S - 14-4-9	74
	S - 3-4-9	48
S12338	S - 14-4-10	74
	S - 3-4-10	48
S12339	S - 14-4-11	74
	S - 3-4-11	48
S12341	S - 4	50
S12341001	D2- 10-1	118
	D2- 5-1	118
S12342	S - 15-1	80
	S - 4-1	50
S12343	S - 15-1-32	80
	S - 4-1-32	50
S12344	S - 15-1-33	80
	S - 4-1-33	50
S12345	S - 15-1-34	80
	S - 4-1-34	50
S12346	S - 15-1-44	80
	S - 4-1-44	50
S12347	S - 15-2	82
	S - 4-2	52
S12348	S - 15-2-9	82
	S - 4-2-9	52
S12349	S - 4-3	52
S12350	S - 4-3-5	52
S12351	S - 15-4	82
	S - 4-4	52
S12352	S - 15-4-7	82
	S - 4-4-7	52
S12353	S - 15-4-8	82
	S - 4-4-8	52
S12354	S - 15-4-9	82
	S - 4-4-9	52
S12355	S - 15-4-10	82
	S - 4-4-10	52
S12356001	B1- 95	114
S12359001	B1- 48	112
S12458000	Y - 19-1	106
S12459000	Y - 19-2	106
S12461001	L - 6-2	18
S12463001	L - 6	18
S12465000	Y - 124-2	108
S12466000	B1- 90	114

CODE	REF.NO.	PAGE
S12466000	Y - 123	108
S12467001	Y - 124	108
S12468000	Y - 130	108
S12469---	S - 15-1-48	80
	S - 4-1-48	50
S12470---	S - 15-1-51	80
	S - 4-1-51	50
S12471---	S - 15-1-52	80
	S - 4-1-52	50
S12475100	S - 1-1-26	38
	S - 12-1-26	56
	S - 13-1-26	64
	S - 14-1-26	72
	S - 15-1-26	80
	S - 2-1-26	42
	S - 3-1-26	46
	S - 4-1-26	50
S12476100	S - 1-1-27	38
	S - 12-1-27	56
	S - 13-1-27	64
	S - 14-1-27	72
	S - 15-1-27	80
	S - 2-1-27	42
	S - 3-1-27	46
	S - 4-1-27	50
S12481000	B1- 110	114
	D3- 15-42	120
	U - 17	92
S12482009	U - 16	92
S12483000	U - 7	92
S12484000	U - 8	92
S12485001	S - 1-4-15	40
	S - 12-4-15	58
	S - 13-4-16	66
	S - 14-4-16	74
	S - 15-4-15	82
	S - 2-4-16	44
	S - 3-4-16	48
	S - 4-4-15	52
S12487000	S - 1-4-20	40
	S - 12-4-20	58
	S - 13-4-21	66
	S - 14-4-21	74
	S - 15-4-20	82
	S - 2-4-21	44
	S - 3-4-21	48
	S - 4-4-20	52
S12488001	D2- 7	118
S12489001	D2- 8	118
S12490001	D2- 9	118
S12491001	D2- 10	118
S12492009	M - 11	20
S12494000	S - 5	40
S12495001	X - 78	102
S12496001	X - 79	102
S12497000	X - 79-1	102
S12498000	X - 79-1-1	102
S12499000	X - 79-5	102
S12500001	X - 79-6	102
S12501001	X - 79-7	102
S12502000	X - 79-12	102
S12506001	B1- 102	114
S12507001	S - 10	40
S12508001	S - 11	40
S12509000	X - 79-17	102
S12565001	Y - 124-1	108
S13103009	C - 36	6

CODE	REF.NO.	PAGE
S13385001	C 7	6
S14328000	S - 1-1-53-3	38
	S - 12-1-53-3	56
	S - 13-1-55-3	66
	S - 14-1-55-3	74
	S - 15-1-59-3	82
	S - 2-1-55-3	44
	S - 3-1-55-3	48
	S - 4-1-59-3	52
	X 34	98
S14461009	P - 128	28
S14462009	P - 128-1	28
S14463009	P - 128-4	28
S14464001	P - 128-11	28
S14465009	P - 128-12	28
S14466001	P - 128-15	28
S14468000	P - 128-17	28
S14469000	P - 128-17-1	28
S14470000	P - 128-20	28
S14471000	P - 128-23	28
S14472000	P - 128-23-1	28
S14473000	P - 128-24	28
S14475009	P - 128-28	28
S14477000	P - 128-29	28
S14478001	P - 128-32	28
S14479001	P - 128-34	28
S14480000	P - 128-35	28
S14481009	P - 128-38	28
S14482009	P - 128-39	28
S14483009	P - 128-40	28
S14484009	P - 128-44	28
S14485009	P - 128-48	28
S14486009	P - 128-51	28
S14487001	A1- 18	110
S14488000	A1- 14	110
	A1- 18-4	110
S14788001	E - 6-2	8
	Z - 10-2	124
S15525001	T - 72	90
S15526001	T - 71	90
S15528001	B1- 106	114
S15530001	T - 6	88
S15531001	T - 7	88
S15532009	T - 1	88
S15533009	B1- 32	112
S15534009	B1- 65	112
S15538001	D3- 15-9	120
	Q - 19	32
S15539001	D3- 15-10	120
	Q - 20	32
S15540000	Q - 40	32
S15541001	Q - 49	32
S15542109	T - 10	88
S15544001	X - 86	102
S15545000	D3- 15-17	120
	Q - 82	34
S15547009	B1- 38	112
S15551001	Q - 87	34
S15556009	T - 5	88
S15557009	B1- 63	112
S15558009	B1- 109	114
S15561000	X - 88	98
S15562000	X - 88-1	98
S15563000	S - 1-1-53-1	38
	S - 12-1-53-1	56
	S - 13-1-55-1	66
	S - 14-1-55-1	74

CODE	REF.NO.	PAGE
S15563000	S - 15-1-59-1	82
	S - 2-1-55-1	44
	S - 3-1-55-1	48
	S - 4-1-59-1	52
S15564000	S - 1-1-53	38
	S - 12-1-53	56
	S - 13-1-55	66
	S - 14-1-55	74
	S - 15-1-59	82
	S - 2-1-55	44
	S - 3-1-55	48
	S - 4-1-59	52
S15565000	S - 8	40
S15566000	S - 9	40
S15567000	T - 39-4	88
S15569001	A1- 7	110
S16170001	F - 23	10
S16452000	Y - 131	108
S16513000	S - 1-10	40
	S - 12-10	62
	S - 13-10	70
	S - 14-10	78
	S - 15-10	86
	S - 2-10	44
	S - 3-10	48
	S - 4-10	52
S16514000	S - 1-9	40
	S - 12-9	62
	S - 13-9	70
	S - 14-9	78
	S - 15-9	86
	S - 2-9	44
	S - 3-9	48
	S - 4-9	52
S16515---	S - 15-1-60	82
	S - 4-1-60	52
S16516---	S - 15-1-61	82
	S - 4-1-61	52
S16517---	S - 15-1-62	82
	S - 4-1-62	52
S16661001	Y - 64	108
S16666000	Y - 132	108
S16667000	W - 1-27-1	94
S16669000	W - 1-35	94
S17701009	W - 1	94
S17702001	R - 35	36
S17703000	P - 24	22
S17704000	P - 33	22
S17705001	R - 46	36
S17706001	Q - 5	32
S17707009	P - 25	22
S17708009	B1- 55	112
S17709001	A1- 18-3	110
S17710001	A1- 18-1	110
S17711101	A1- 18-2	110
S17716009	D3- 15-11	120
	Q - 21	32
S17717009	D3- 15-12	120
	Q - 23	32
S17718000	P - 94	24
S17719009	D3- 15-1	120
	Q - 1	32
S17720009	B1- 64	112
	D3- 15-36	120
S17721009	B1- 114	114
	D3- 15-41	120
S17722009	B1- 113	114

CODE	REF.NO.	PAGE
S17722009	D3 15 40	120
S17723001	D3 15 49	120
	D4- 16 25	122
	X 4	96
S17724001	D3- 15-18	120
	Q 83	34
S17725000	D3- 15-5	120
	Q - 13	32
S17726000	Q 13-1	32
S17727000	D3- 15-7	120
	Q - 16	32
S17728001	D3- 15-52	120
	D4- 16-28	122
	X - 7	96
S17729000	X - 1-3	96
S17730001	X - 1-2	96
S18658001	Y - 73	108
S19063101	C - 6	6
	D3- 15-47	120
	D4- 16-23	122
	Z - 11	124
S19064001	C - 6-1	6
	Z - 11-1	124
S19065101	C - 6-2	6
	Z - 11-2	124
S19066001	D3- 15-19	120
	D4- 16-1	122
	Q - 90	34
S19067000	X - 1-2-1	96
	X - 1-3-1	96
S19068000	C - 6-4	6
	Z - 11-4	124
S19069001	S - 12-3-6	60
	S - 13-3-6	68
	S - 14-3-6	76
	S - 15-3-6	84
S19070000	S - 12-3-7	60
	S - 13-3-7	68
	S - 14-3-7	76
	S - 15-3-7	84
S19071000	S - 12-3-12	60
	S - 13-3-12	68
	S - 14-3-12	76
	S - 15-3-12	84
S19072001	S - 12-3-13	60
	S - 13-3-13	68
	S - 14-3-13	76
	S - 15-3-13	84
S19073001	S - 12-3-14	60
	S - 13-3-14	68
	S - 14-3-14	76
	S - 15-3-14	84
S19074001	S - 12-3-17	60
	S - 13-3-17	68
	S - 14-3-17	76
	S - 15-3-17	84
S19075001	S - 12-3-18	60
	S - 13-3-18	68
	S - 14-3-18	76
	S - 15-3-18	84
S19076000	S - 12-3-21	60
	S - 12-3-39	60
	S - 13-3-21	68
	S - 13-3-39	68
	S - 14-3-21	76
	S - 14-3-39	76
	S - 15-3-21	84

CODE	REF.NO.	PAGE
S19076000	S 15-3-39	84
S19077000	S - 12-3-22	60
	S - 13-3-22	68
	S - 14-3-22	76
	S - 15-3-22	84
S19078000	S - 12-3-21-1	60
	S - 12-3-22-1	60
	S - 12-3-39-1	60
	S - 13-3-21-1	68
	S - 13-3-22-1	68
	S - 13-3-39-1	68
	S - 14-3-21-1	76
	S - 14-3-22-1	76
	S - 14-3-39-1	76
	S - 15-3-21-1	84
	S - 15-3-22-1	84
	S - 15-3-39-1	84
S19080000	A - 34	2
	D3- 15-43	120
	D4- 16-19	122
S19508000	D3- 15-57	120
	D4- 16-31	122
	Y - 140	108
S19509000	D3- 15-30	120
	D4- 16-14	122
	Y - 133	108
S19510000	D3- 15-31	120
	D4- 16-15	122
	Y - 134	108
S19511000	D3- 15-32	120
	D4- 16-16	122
	Y - 135	108
S19512000	S - 12-3-32	60
	S - 13-3-32	68
	S - 14-3-32	76
	S - 15-3-32	84
S19513000	D3- 15-35	120
	V - 1	92
S19516001	D3- 15	120
S19517001	D4- 16	122
S19518000	D3- 15-56	120
	V - 6	92
	Y - 2	104
S19520109	W - 1-27	94
S19522001	U - 6	92
S19523001	S - 12-3-27	60
S19540001	S - 13-3-27	68
	S - 14-3-27	76
	S - 15-3-27	84
S19541001	S - 12-3-28	60
	S - 13-3-28	68
	S - 14-3-28	76
	S - 15-3-28	84
S19542001	S - 12-3-34	60
	S - 13-3-34	68
	S - 14-3-34	76
	S - 15-3-34	84
S19543001	S - 12-3-35	60
	S - 13-3-35	68
	S - 14-3-35	76
	S - 15-3-35	84
S19544001	S - 12-3-38	60
	S - 13-3-38	68
	S - 14-3-38	76
	S - 15-3-38	84
S19545002	S - 12-3-40	60
	S - 13-3-40	68

CODE	REF.NO.	PAGE
S19545002	S 14 3 40	76
	S - 15-3-40	84
S19546001	S - 12-3-44	60
	S - 13-3-44	68
	S - 14-3-44	76
	S - 15-3-44	84
S19547000	S - 12-3-48	60
	S - 13-3-48	68
	S - 14-3-48	76
	S - 15-3-48	84
S19548000	S - 12-3-48-1	60
	S - 13-3-48-1	68
	S - 14-3-48-1	76
	S - 15-3-48-1	84
S19549000	S - 12-3-66	62
	S - 13-3-66	70
	S - 14-3-66	78
	S - 15-3-66	86
	X - 91-1	98
S19550000	D3- 15-22	120
	D4- 16-4	122
	Q - 93	34
S19551000	S - 12-3-67	62
	S - 13-3-67	70
	S - 14-3-67	78
	S - 15-3-67	86
S19552001	S - 12-3-63	62
	S - 13-3-63	70
	S - 14-3-63	78
	S - 15-3-63	86
S19553000	D3- 15-6	120
	Q - 14	32
S19554000	D3- 15-28	120
	D4- 16-12	122
	X - 91	98
S19555000	X - 91-3	98
S19556000	X - 91-2	98
S19557000	S - 12-3-61	62
	S - 13-3-61	70
	S - 14-3-61	78
	S - 15-3-61	86
S19558000	S - 12-3-62	62
	S - 13-3-62	70
	S - 14-3-62	78
	S - 15-3-62	86
S19559001	D3- 15-48	120
	D4- 16-24	122
	X - 1	96
	S - 12	56
S19561---	D2- 11-1	118
S19561001	S - 12-3-1	60
S19562---	S - 12-3-2	60
S19563---	S - 12-3-3	60
S19564---	S - 12-3-33	60
S19565000	S - 12-3-51	62
S19566---	S - 13	64
S19567---	D2- 12-1	118
S19567001	S - 13-3-1	68
S19568---	S - 13-3-2	68
S19569---	S - 13-3-3	68
S19570---	S - 13-3-33	68
S19571---	S - 13-3-51	70
S19572---	S - 14	72
S19573---	D2- 13-1	118
S19573001	S - 14-3-1	76
S19574---	S - 14-3-2	76
S19575---	S - 14-3-3	76

CODE	REF.NO.	PAGE
S19577---	S - 14-3-33	76
S19578---	S - 14-3-51	78
S19579---	S - 15	80
S19579001	D2- 14-1	118
S19580---	S - 15-3-1	84
S19581---	S - 15-3-2	84
S19582---	S - 15-3-3	84
S19583000	S - 15-3-33	84
S19584---	S - 15-3-51	86
S19585000	D3- 15-26	120
	D4- 16-10	122
	X - 89	98
S19586000	D3- 15-27	120
	D4- 16-11	122
	X - 90	98
S19587001	D2- 11	118
S19588001	D2- 12	118
S19589001	D2- 13	118
S19590001	D2- 14	118
S19669---	S - 12-3	60
S19670---	S - 13-3	68
S19671---	S - 14-3	76
S19672---	S - 15-3	84
S19675000	X - 93	102
S19676000	X - 93-1	102
S19971000	D3- 15-29	120
	D4- 16-13	122
	X - 92	98
S19972000	X - 92-1	98
S19973000	X - 92-2	98
S20789000	P - 93	24
S20850001	B1- 29	112
S20851000	B1- 115	114
S20890000	S - 12-3-74	62
	S - 13-3-74	70
	S - 14-3-74	78
	S - 15-3-74	86
S20891000	S - 12-3-77	62
	S - 13-3-77	70
	S - 14-3-77	78
	S - 15-3-77	86
	S - 16	40
S21121001	S - 17	40
S21122001	S - 18	40
S21123001	D2- 10-2	118
U42775001	D2- 11-2	118
	D2- 12-2	118
	D2- 13-2	118
	D2- 14-2	118
	D2- 2-2	118
	D2- 3-2	118
	D2- 4-2	118
	D2- 5-2	118
	D2- 7-2	118
	D2- 8-2	118
	D2- 9-2	118
	Z - 18	126
	Y - 2-17	104
002300803	B1- 70	112
003400804	P - 128-36	28
	W - 1-2	94
004300513	B1- 88	114
004400702	P - 32	22
	X - 79-8	102
004401414	S - 12-3-15	60
007402512	S - 13-3-15	68
	S - 14-3-15	76

CODE	REF.NO.	PAGE
007402512	S - 15-3-15	84
008400604	B1 112	114
	B1 56	112
	B1 66	112
	D3- 15-13	120
	P 113	26
	P - 119	26
	Q - 24	32
	R - 52	36
008400806	B1- 111	114
013781012	B - 13	4
014060632	B1- 41	112
	P - 41	22
	P - 58	24
	R - 10	36
	R - 12	36
	R - 20	36
	T - 26	88
	T - 32	88
	T - 73	90
014061032	R - 18	36
014300332	W - 1-6	94
014400422	A - 16	2
	B - 4	4
	C - 40	6
	M - 10	20
014400522	H - 2	14
	P - 12	22
	P - 77	24
	P - 80	24
	Q - 74	34
	R - 44	36
	S - 1-1-20	38
	S - 12-1-20	56
	S - 13-1-20	64
	S - 14-1-20	72
	S - 15-1-20	80
	S - 2-1-20	42
	S - 3-1-20	46
	S - 4-1-20	50
	X - 33	98
014400822	F - 16	10
	F - 29	10
	F - 6	10
	H - 20	14
	J - 25	16
	J - 47	16
014500522	A - 22	2
	A - 25	2
	C - 28	6
	E - 3	8
	M - 11-1	20
	P - 128-33	28
	P - 88	24
	P - 92	24
	P - 97	24
	Q - 65	34
	Q - 70	34
	S - 1-2-5	40
	S - 1-4-4	40
	S - 12-2-5	58
	S - 12-4-4	58
	S - 13-2-5	66
	S - 13-4-4	66
	S - 14-2-5	74
	S - 14-4-4	74
	S - 15-2-5	82

CODE	REF.NO.	PAGE
014500522	S - 15-4-4	82
	S - 2-2-5	44
	S - 2-4-4	44
	S - 3-2-5	48
	S - 3-4-4	48
	S - 4-2-5	52
	S - 4-4-4	52
	T - 17	88
014680422	W - 1-9	94
014680622	J - 41	16
014710522	C - 36-1	6
014770622	B - 27	4
	C - 23	6
	F - 13	10
	F - 2	10
	F - 32	10
	J - 29	16
	M - 12-2	20
014771022	B - 11	4
	J - 3	16
018060822	X - 2	96
018061422	P - 44	24
	P - 53	24
	P - 9	22
	X - 15	96
018062022	P - 49	24
	P - 67	24
	R - 2	36
	R - 28	36
	T - 63	90
	T - 74	90
018062522	P - 19	22
	P - 40	22
	P - 57	24
	R - 15	36
	T - 65	90
018063022	R - 31	36
018081222	P - 35	22
	P - 6	22
018081422	B1- 44	112
018081622	T - 11	88
	X - 78-2	102
018082022	B1- 33	112
	B1- 36	112
	B1- 39	112
	B1- 79	114
	Q - 62	34
	Q - 67	34
	Q - 76	34
	Y - 45	106
018082522	P - 2	22
	T - 4	88
018300532	S - 1-4-11	40
	S - 1-4-21	40
	S - 12-4-11	58
	S - 12-4-21	58
	S - 13-4-12	66
	S - 13-4-22	66
	S - 14-4-12	74
	S - 14-4-22	74
	S - 15-4-11	82
	S - 15-4-21	82
	S - 2-4-12	44
	S - 2-4-22	44
	S - 3-4-12	48
	S - 3-4-22	48
	S - 4-4-11	52

CODE	REF.NO.	PAGE
018300532	S 4-4-21	52
018400632	S 1-1-28	38
	S 1-1-36	38
	S 12-1-28	56
	S 12-1-36	56
	S 13-1-28	64
	S 13-1-36	64
	S 14-1-28	72
	S 14-1-36	72
	S 15-1-28	80
	S 15-1-35	80
	S 2-1-28	42
	S 2-1-36	42
	S 3-1-28	46
	S 3-1-36	46
	S 4-1-28	50
	S 4-1-35	50
018400822	B1- 30	112
	K - 13	18
	T - 51	90
	Y - 50	106
	Y - 96	108
018400832	B1- 12	112
	B1- 15	112
	B1- 18	112
	B1- 21	112
	B1- 24	112
	B1- 8	112
	D3- 15-50	120
	D4- 16-26	122
	P - 128-41	28
	P - 128-8	28
	Q - 50	32
	Q - 6	32
	Q - 85	34
	R - 36	36
	R - 40	36
	S - 15-1-49	80
	S - 4-1-49	50
	T - 19	88
	U - 20	92
	X - 1-8	96
	X - 5	96
	Y - 124-3	108
	Y - 98	108
018401022	B1- 107	114
	M - 8	20
	P - 108	26
	P - 126	26
	P - 128-2	28
	P - 86	24
	S - 1-3-2	40
	S - 12-3-69	62
	S - 13-3-69	70
	S - 14-3-69	78
	S - 15-3-69	86
	S - 2-3-2	44
	S - 3-3-2	48
	S - 4-3-2	52
018401222	F - 22	10
	P - 71	26
	S - 1-1-11	38
	S - 12-1-11	56
	S - 13-1-11	64
	S - 14-1-11	72
	S - 15-1-11	80
	S - 2-1-11	42

CODE	REF.NO.	PAGE
018401222	S - 3-1-11	46
	S - 4-1-11	50
	Y - 128	104
018401622	B1- 73	114
	G - 36	12
	P - 100	24
	P - 103	26
	P - 128-37	28
	P - 82	24
	Q - 41	32
	R - 33	36
	X - 25	98
018402032	S - 1-2-3	40
	S - 12-2-3	58
	S - 13-2-3	66
	S - 14-2-3	74
	S - 15-2-3	82
	S - 2-2-3	44
	S - 3-2-3	48
	S - 4-2-3	52
018402522	P - 128-58	30
018403022	X - 64	98
018500822	E - 10	8
	P - 128-18	28
	P - 128-21	28
018501022	P - 123	26
	P - 128-45	28
	P - 128-49	28
	P - 128-52	28
	P - 27	22
018501222	B1- 27	112
	B1- 76	114
	N - 5	20
	P - 64	24
	T - 41	88
	T - 45	90
018501622	A - 20	2
	A1- 2	110
	A1- 8	110
	L - 4	18
	P - 111	26
	P - 128-26	28
	P - 128-5	28
	Q - 11	32
	Q - 47	32
	R - 42	36
	X - 79-2	102
018502022	A1- 11	110
	A1- 15	110
	A1- 18-5	110
	A1- 5	110
	B1- 94	114
	P - 128-13	28
	P - 128-16	28
	Q - 27	32
	Q - 44	32
	S - 12-3-25	60
	S - 13-3-25	68
	S - 14-3-25	76
	S - 15-3-25	84
018502522	B1- 53	112
	Q - 54	32
	S - 1-1-3	38
	S - 1-4-2	40
	S - 12-1-3	56
	S - 12-4-2	58
	S - 13-1-3	64

CODE	REF.NO.	PAGE	
018502522	S - 13-4-2	66	
	S - 14-1-3	72	
	S - 14-4-2	74	
	S - 15-1-3	80	
	S - 15-4-2	82	
	S - 2-1-3	42	
	S - 2-4-2	44	
	S - 3-1-3	46	
	S - 3-4-2	48	
	S - 4-1-3	50	
	S - 4-4-2	52	
	018503022	A1- 18-6	110
		D3- 15-53	120
D4- 16-29		122	
Q - 32		32	
X - 1-4		96	
021060206	X - 8	96	
	S - 1-1-52	38	
	S - 12-1-52	56	
	S - 13-1-54	64	
	S - 14-1-53	72	
	S - 15-1-58	82	
	S - 2-1-54	42	
	S - 3-1-53	46	
	S - 4-1-58	52	
	X - 78-9	102	
021080302	B1- 96	114	
	S - 1-4-18	40	
021200203	S - 12-4-18	58	
	S - 13-4-19	66	
	S - 14-4-19	74	
	S - 15-4-18	82	
	S - 2-4-19	44	
	S - 3-4-19	48	
	S - 4-4-18	52	
	T - 55	90	
	G - 37	12	
	W - 1-26	94	
021400103	Z - 25-1	126	
	Z - 6-4-3	124	
	Z - 6-7-3	124	
021400202	S - 12-3-26	60	
	S - 13-3-26	68	
	S - 14-3-26	76	
	S - 15-3-26	84	
	L - 9	18	
021500106	Y - 102	108	
	Y - 2-18	104	
021500303	S - 1-4-13	40	
	S - 12-4-13	58	
	S - 13-4-14	66	
	S - 14-4-14	74	
	S - 15-4-13	82	
	S - 2-4-14	44	
	S - 3-4-14	48	
	S - 4-4-13	52	
	W - 1-30	94	
	Y - 103	108	
	025030132	S - 15-1-63	82
		S - 4-1-63	52
	025030133	B1- 74	114
K - 14		18	
P - 128-10		28	
Q - 52		32	
Q - 57		32	
Q - 8		32	
Q - 88		34	
025030232		W - 1-30	94
		Y - 103	108
		S - 15-1-63	82
	S - 4-1-63	52	
	025030233	B1- 74	114
		K - 14	18
		P - 128-10	28
		Q - 52	32
		Q - 57	32
		Q - 8	32
		Q - 88	34

CODE	REF.NO.	PAGE	
025040232	R - 45	36	
	S - 1-1-38	38	
	S - 1-2-2	40	
	S - 1-3-4	40	
	S - 12-1-38	56	
	S - 12-2-2	58	
	S - 12-3-71	62	
	S - 13-1-38	64	
	S - 13-2-2	66	
	S - 13-3-71	70	
	S - 14-1-38	72	
	S - 14-2-2	74	
	S - 14-3-71	78	
	S - 15-1-37	80	
	S - 15-2-2	82	
	S - 15-3-71	86	
	S - 2-1-38	42	
	S - 2-2-2	44	
	S - 2-3-4	44	
	S - 3-1-38	46	
	S - 3-2-2	48	
	S - 3-3-4	48	
	S - 4-1-37	50	
	S - 4-2-2	52	
	S - 4-3-4	52	
	W - 1-23	94	
	Y - 139	108	
	025040233	A - 38	2
		A1- 18-13	110
		D3- 15-15	120
		D3- 15-46	120
		D4- 16-22	122
		D4- 16-9	122
		L - 12	18
		P - 128-43	28
		P - 128-62	30
		P - 61	24
		Q - 35	32
		Q - 38	32
		R - 51	36
		S - 1-1-8	38
		S - 12-1-8	56
S - 12-3-30		60	
S - 12-3-47		60	
S - 12-3-59		62	
S - 13-1-8		64	
S - 13-3-30		68	
S - 13-3-47		68	
S - 13-3-59		70	
S - 14-1-8		72	
S - 14-3-30		76	
S - 14-3-47		76	
S - 14-3-59		78	
S - 15-1-8		80	
S - 15-3-30		84	
S - 15-3-47		84	
S - 15-3-59		86	
S - 2-1-8		42	
S - 3-1-8		46	
S - 4-1-8		50	
T - 61	90		
U - 22	92		
Y - 115	108		
Y - 41	106		
Y - 56	106		
Y - 62	106		
Y - 95	108		

CODE	REF.NO.	PAGE	
025050232	A1 12	110	
	A1 16	110	
	N 7	20	
	P - 128-47	28	
	P - 128-54	28	
	P - 29	22	
	S 1-1-5	38	
	S - 1-4-6	40	
	S - 12-1-5	56	
	S - 12-4-6	58	
	S - 13-1-5	64	
	S - 13-4-6	66	
	S - 14-1-5	72	
	S - 14-4-6	74	
	S - 15-1-5	80	
	S - 15-4-6	82	
	S - 2-1-5	42	
	S - 2-4-6	44	
	S - 3-1-5	46	
	S - 3-4-6	48	
	S - 4-1-5	50	
	S - 4-4-6	52	
	025060232	P - 46	24
		P - 51	24
		P - 69	24
		R - 29	36
		T - 67	90
		T - 75	90
	025080232	X - 98	100
		B1- 105	114
		P - 37	22
	028030242	P - 4	22
		X - 78-4	102
	028030243	D - 3	8
		D - 6	8
		L - 6-4	18
L - 8		18	
M - 15		20	
M - 6		20	
S - 1-4-12		40	
S - 1-8		40	
S - 12-4-12		58	
S - 12-8		62	
S - 13-4-13		66	
S - 13-8		70	
S - 14-4-13		74	
S - 14-8		78	
S - 15-4-12		82	
S - 15-8		86	
S - 2-4-13		44	
S - 2-8		44	
S - 3-4-13		48	
S - 3-8		48	
S - 4-4-12		52	
S - 4-8		52	
W - 1-4		94	
X - 79-14		102	
028030243		D3- 15-34	120
		D4- 16-18	122
		E - 8	8
		Q - 31	32
		S - 1-1-15	38
		S - 12-1-15	56
		S - 12-3-24	60
		S - 12-3-41	60
		S - 13-1-15	64
		S - 13-3-24	68

CODE	REF.NO.	PAGE	
028030243	S - 13-3-41	68	
	S - 14-1-15	72	
	S - 14-3-24	76	
	S - 14-3-41	76	
	S - 15-1-15	80	
	S - 15-3-24	84	
	S - 15-3-41	84	
	S - 2-1-15	42	
	S - 3-1-15	46	
	S - 4-1-15	50	
	T - 29	88	
	T - 35	88	
	T - 58	90	
	Y - 101	108	
	Y - 137	108	
	Y - 2-19	104	
	Y - 67	108	
	028040242	A - 41	2
		B1- 108	114
		B1- 13	112
		B1- 16	112
B1- 19		112	
B1- 22		112	
B1- 25		112	
B1- 31		112	
B1- 9		112	
D3- 15-24		120	
D3- 15-51		120	
D4- 16-27		122	
D4- 16-6		122	
P - 101		24	
P - 104		26	
P - 109		26	
P - 127		26	
P - 128-3		28	
P - 128-59		30	
P - 128-9		28	
P - 72		26	
P - 83		24	
Q - 42		32	
Q - 51		32	
Q - 7		32	
Q - 86		34	
Q - 95		34	
R - 34		36	
R - 37		36	
R - 41		36	
S - 1-1-12		38	
S - 1-1-29		38	
S - 1-1-37		38	
S - 1-2-4		40	
S - 1-3-3		40	
S - 12-1-12		56	
S - 12-1-29		56	
S - 12-1-37		56	
S - 12-2-4		58	
S - 12-3-20		60	
S - 12-3-70		62	
S - 13-1-12		64	
S - 13-1-29	64		
S - 13-1-37	64		
S - 13-2-4	66		
S - 13-3-20	68		
S - 13-3-70	70		
S - 14-1-12	72		
S - 14-1-29	72		
S - 14-1-37	72		

CODE	REF.NO.	PAGE
028040242	S 14-2-4	74
	S 14-3-20	76
	S 14-3-70	78
	S 15-1-12	80
	S 15-1-29	80
	S 15-1-36	80
	S 15-1-50	80
	S 15-2-4	82
	S 15-3-20	84
	S 15-3-70	86
	S 2-1-12	42
	S 2-1-29	42
	S 2-1-37	42
	S 2-2-4	44
	S 2-3-3	44
	S 3-1-12	46
	S 3-1-29	46
	S 3-1-37	46
	S 3-2-4	48
	S 3-3-3	48
	S 4-1-12	50
	S 4-1-29	50
	S 4-1-36	50
	S 4-1-50	50
	S 4-2-4	52
	S 4-3-3	52
	T 20	88
	T 52	90
	T 54	90
	U 21	92
	W 1-24	94
	W 1-34	94
	X 1-9	96
	X 22	96
	X 26	98
	X 6	96
	X 65	98
	Y 124-4	108
	Y 129	104
	Y 51	106
	Y 97	108
	Y 99	108
028040243	D3- 15-21	120
	D4- 16-3	122
	N 12	20
	P 128-31	28
	P 128-42	28
	Q 92	34
	S 1-1-40	38
	S 1-1-50	38
	S 1-4-19	40
	S 12-1-40	56
	S 12-1-50	56
	S 12-3-10	60
	S 12-3-16	60
	S 12-3-31	60
	S 12-3-37	60
	S 12-3-43	60
	S 12-3-46	60
	S 12-3-5	60
	S 12-3-50	62
	S 12-3-53	62
	S 12-3-65	62
	S 12-3-76	62
	S 12-3-79	62
	S 12-4-19	58
	S 13-1-40	64

CODE	REF.NO.	PAGE
028040243	S 13-1-52	64
	S 13-3-10	68
	S 13-3-16	68
	S 13-3-31	68
	S 13-3-37	68
	S 13-3-43	68
	S 13-3-46	68
	S 13-3-5	68
	S 13-3-50	70
	S 13-3-53	70
	S 13-3-65	70
	S 13-3-76	70
	S 13-3-79	70
	S 13-4-20	66
	S 14-1-40	72
	S 14-1-51	72
	S 14-3-10	76
	S 14-3-16	76
	S 14-3-31	76
	S 14-3-37	76
	S 14-3-43	76
	S 14-3-46	76
	S 14-3-5	76
	S 14-3-50	78
	S 14-3-53	78
	S 14-3-65	78
	S 14-3-76	78
	S 14-3-79	78
	S 14-4-20	74
	S 15-1-39	80
	S 15-1-56	80
	S 15-3-10	84
	S 15-3-16	84
	S 15-3-31	84
	S 15-3-37	84
	S 15-3-43	84
	S 15-3-46	84
	S 15-3-5	84
	S 15-3-50	86
	S 15-3-53	86
	S 15-3-65	86
	S 15-3-76	86
	S 15-3-79	86
	S 15-4-19	82
	S 2-1-40	42
	S 2-1-52	42
	S 2-4-20	44
S 3-1-40	46	
S 3-1-51	46	
S 3-4-20	48	
S 4-1-39	50	
S 4-1-56	50	
S 4-4-19	52	
U 15	92	
W 3	94	
Y 94	108	
028050242	A1- 13	110
	A1- 17	110
	A1- 18-8	110
	A1- 3	110
	A1- 6	110
	A1- 9	110
	B1- 28	112
	B1- 54	112
	B1- 77	114
	D3- 15-54	120
D4- 16-30	122	

CODE	REF.NO.	PAGE	
028050242	E 11	8	
	L 5	18	
	N 6	20	
	P 124	26	
	P 128-19	28	
	P 128-22	28	
	P 128-27	28	
	P 128-46	28	
	P 128-50	28	
	P 128-53	28	
	P 128-6	28	
	P 16	22	
	P 28	22	
	P 65	24	
	Q 12	32	
	Q 28	32	
	Q 45	32	
	Q 48	32	
	Q 79	34	
	R 43	36	
	S - 1-1-4	38	
	S - 1-4-3	40	
	S - 12-1-4	56	
	S - 12-4-3	58	
	S - 13-1-4	64	
	S - 13-4-3	66	
	S - 14-1-4	72	
	S - 14-4-3	74	
	S - 15-1-4	80	
	S - 15-4-3	82	
	S - 2-1-4	42	
	S - 2-4-3	44	
	S - 3-1-4	46	
	S - 3-4-3	48	
	S - 4-1-4	50	
	S - 4-4-3	52	
	T 42	88	
	T 46	90	
	X 1-5	96	
	X 79-3	102	
	X 9	96	
	028050243	P 117	26
		P 128-25	28
028050246	Q 15	32	
	Z 6-7-2	124	
028060242	P 10	22	
	P 45	24	
	P 50	24	
	P 54	24	
	P 68	24	
	R 16	36	
	R 3	36	
	R 30	36	
	T 64	90	
	T 66	90	
	T 76	90	
	X 16	96	
	X 3	96	
	028060243	M 2	20
		S - 1-1-51	38
		S - 12-1-51	56
		S - 13-1-53	64
		S - 14-1-52	72
		S - 15-1-57	82
		S - 2-1-53	42
S - 3-1-52		46	
S - 4-1-57		52	

CODE	REF.NO.	PAGE	
028080242	B1 - 34	112	
	B1 - 37	112	
	B1 - 40	112	
	B1 - 45	112	
	B1 - 80	114	
	P 3	22	
	P 36	22	
	P 7	22	
	Q 63	34	
	Q 68	34	
	Q 77	34	
	T 12	88	
	T 3	88	
	X 78-3	102	
	Y 46	106	
	028350242	H 21	14
		034311302	C1- 1-3
	047301042	W 1-16	94
	047502242	B1 - 50	112
	048040342	C 18	6
		C 35	6
	048050342	S - 1-1-23	38
		S - 1-1-25	38
		S - 12-1-23	56
		S - 12-1-25	56
		S - 13-1-23	64
		S - 13-1-25	64
S - 14-1-23		72	
S - 14-1-25		72	
S - 15-1-23		80	
S - 15-1-25		80	
S - 2-1-23		42	
S - 2-1-25		42	
S - 3-1-23		46	
S - 3-1-25		46	
S - 4-1-23		50	
S - 4-1-25		50	
048060342		E 5	8
	J 35	16	
048070342	C 32	6	
	048080142	F 33	10
048100142	F 11	10	
	048120142	P 128-14	28
048150142	P 23	22	
	B 8	4	
	J 11	16	
	048220242	F 26	10
	048320242	B 30	4
	048350242	D3- 15-4	120
		F 8	10
	Q 4	32	
	Z 6-7-5	124	
	050501406	Z 25-3	126
Z 6-7-4		124	
052400806	A1- 18-11	110	
	B1- 100	114	
	B1- 103	114	
	Y 47	106	
	S - 1-2-8	40	
060300414	S - 12-2-8	58	
	S - 13-2-8	66	
	S - 14-2-8	74	
	S - 2-2-8	44	
	S - 3-2-8	48	
	S - 4-2-8	52	
	060660512	W 1-14	94
060670612	H 15	14	

CODE	REF.NO.	PAGE
060670612	H - 9	14
062061606	M 3	20
062300414	S 15-2-8	82
062300502	S 1 7	40
	S - 12-7	62
	S - 13-7	70
	S - 14-7	78
	S - 15-7	86
	S - 2-7	44
	S - 3-7	48
	S - 4-7	52
062300505	Y - 68	108
062300506	Y - 100	108
062300605	W - 1-3	94
062300606	D3- 15-33	120
	D4- 16-17	122
	Y - 136	108
062300612	D - 2	8
	D - 5	8
	G - 23	12
	G - 33	12
	G - 54	12
	J - 49	16
	L - 6-3	18
	L - 7	18
	M - 14	20
	M - 5	20
062300616	W - 1-29	94
062300805	Y - 65	108
062400616	N - 11	20
	S - 12-3-4	60
	S - 12-3-57	62
	S - 12-3-64	62
	S - 12-3-9	60
	S - 13-3-4	68
	S - 13-3-57	70
	S - 13-3-64	70
	S - 13-3-9	68
	S - 14-3-4	76
	S - 14-3-57	78
	S - 14-3-64	78
	S - 14-3-9	76
	S - 15-3-4	84
	S - 15-3-57	86
	S - 15-3-64	86
	S - 15-3-9	84
062400806	A1- 18-12	110
	D3- 15-14	120
	D4- 16-8	122
	P - 128-30	28
	P - 128-61	30
	P - 62	24
	Q - 34	32
	Q - 37	32
	Q - 56	32
	R - 50	36
	S - 1-4-16	40
	S - 12-3-29	60
	S - 12-3-36	60
	S - 12-3-42	60
	S - 12-3-45	60
	S - 12-3-52	62
	S - 12-3-58	62
	S - 12-3-78	62
	S - 12-4-16	58
	S - 13-3-29	68
	S - 13-3-36	68

CODE	REF.NO.	PAGE
062400806	S - 13-3-42	68
	S - 13-3-45	68
	S - 13-3-52	70
	S - 13-3-58	70
	S - 13-3-78	70
	S - 13-4-17	66
	S - 14-3-29	76
	S - 14-3-36	76
	S - 14-3-42	76
	S - 14-3-45	76
	S - 14-3-52	78
	S - 14-3-58	78
	S - 14-3-78	78
	S - 14-4-17	74
	S - 15-3-29	84
	S - 15-3-36	84
	S - 15-3-42	84
	S - 15-3-45	84
	S - 15-3-52	86
	S - 15-3-58	86
	S - 15-3-78	86
	S - 15-4-16	82
	S - 2-4-17	44
	S - 3-4-17	48
	S - 4-4-16	52
	T - 60	90
	U - 23	92
	W - 2	94
	Y - 114	108
	Y - 40	106
	Y - 55	106
	Y - 61	106
062400812	A - 40	2
	D3- 15-23	120
	D4- 16-5	122
	G - 31	12
	G - 35	12
	H - 11	14
	J - 8	16
	Q - 94	34
	X - 21	96
062401006	A - 37	2
	D3- 15-20	120
	D3- 15-45	120
	D4- 16-2	122
	D4- 16-21	122
	L - 11	18
	Q - 91	34
	S - 1-1-49	38
	S - 1-1-7	38
	S - 12-1-49	56
	S - 12-1-7	56
	S - 13-1-51	64
	S - 13-1-7	64
	S - 14-1-50	72
	S - 14-1-7	72
	S - 15-1-55	80
	S - 15-1-7	80
	S - 2-1-51	42
	S - 2-1-7	42
	S - 3-1-50	46
	S - 3-1-7	46
	S - 4-1-55	50
	S - 4-1-7	50
	U - 14	92
	Y - 93	108
062401012	A - 14	2

CODE	REF NO.	PAGE
062401012	A 29	2
	A 3	2
	B 7	4
	F 10	10
	G 16	12
	H 13	14
	L 3	18
	S 12-3-19	60
	S 13-3-19	68
	S 14-3-19	76
	S 15-3-19	84
	W 1-25	94
	W 1-33	94
062401016	S 12-3-8	60
	S 13-3-8	68
	S 14-3-8	76
	S 15-3-8	84
062401416	S 1-4-17	40
	S 12-3-75	62
	S 12-4-17	58
	S 13-3-75	70
	S 13-4-18	66
	S 14-3-75	78
	S 14-4-18	74
	S 15-3-75	86
	S 15-4-17	82
	S 2-4-18	44
	S 3-4-18	48
	S 4-4-17	52
062402016	S 1-1-41	38
	S 12-1-41	56
	S 12-3-49	60
	S 13-1-41	64
	S 13-3-49	68
	S 14-1-41	72
	S 14-3-49	76
	S 15-1-40	80
	S 15-3-49	84
	S 2-1-41	42
	S 3-1-41	46
	S 4-1-40	50
062501202	Q 78	34
062501406	Z 6-4-2	124
062670412	B 24	4
062670512	G 14	12
	G 5	12
062670612	B 25	4
062670812	K 6	18
062671612	K 8	18
062680712	H 7	14
062680812	X 23	96
062681012	B1 83	114
	B1 86	114
	Y 124-7	108
062711412	C 26	6
	J 20	16
	F 27	10
072060860	G 8	12
081001670	G 48	12
081005670	G 40	12
081024070	A 18	2
100032003	N 15	20
	X 87	102
	E 7	8
100080003	W 1-21	94
100136001	B 9-2	4
100251001	B 18	4
100260001		

CODE	REF.NO.	PAGE
100400000	H - 4	14
100401001	W - 1-20	94
100402004	H - 17-3	14
100573001	H - 16	14
100645003	J - 7	16
100887001	Z - 3-1	124
101125000	A1 - 18-7	110
101572101	Z - 2-3	124
101706001	F - 17-1	10
102538007	C - 6-3	6
	Z - 11-3	124
102571003	J - 17	16
102630001	B - 22	4
102843004	J - 5	16
103950003	H - 18	14
104449009	A - 4	2
	G - 2	12
	A - 5	2
104450109	B - 10	4
104464001	H - 17-7	14
104525001	A - 6	2
104821009	J - 28	16
105234003	U - 11	92
106147002	G - 57	12
106629002	Z - 3-2	124
107780001	G - 7	12
108804001	C - 17	6
109763002	K - 3	18
110161004	J - 42	16
110201001	B - 14	4
110367001	J - 34	16
	C - 1	6
111466001	H - 6	14
111469101	G - 9	12
111863001	G - 6	12
111865009	W - 1-12	94
111942001	W - 1-13	94
111943001	G - 25	12
112758009	Q - 89	34
113431002	H - 17-10	14
114294001	Z - 8	124
114483002	U - 12	92
114486002	B - 19	4
114908001	F - 20	10
115007001	Z - 3-7	124
115157001	H - 17-2	14
116922001	G - 13	12
117150001	B - 16	4
117242001	T - 62	90
117934009	Z - 3-5	124
118064001	Z - 2-2	124
118837001	Z - 1	124
122991001	Z - 6-10	124
126863001	U - 13	92
133172003	B - 12-2	4
140004001	G - 42	12
140208001	X - 84	98
140542001	B - 21	4
140553102	G - 22	12
140647001	G - 32	12
	G - 53	12
140682001	X - 1-2-6	96
	X - 7-6	96
	X - 93-4	102
	C - 3	6
141207001	C - 4	6
141208001	C - 5	6
141728001		

CODE	REF.NO.	PAGE
142359001	G 19	12
142403001	C 9	6
142443001	Z 2-1	124
142721001	Z 3-4	124
143488000	J 36-2	16
144086001	G 60	12
144504001	H 1-3	14
144508001	U 10	92
145446001	H 17-5	14
	W 1-19	94
145465001	B 12-1	4
145468001	B 17	4
145472001	C 2	6
145474001	C 13	6
145475101	C 16	6
145478001	C 21	6
145522001	H 8	14
145571101	W 1-18	94
145580001	C 12	6
145619001	G 27	12
145624000	B 12-4	4
145688000	B 23	4
145737001	G 12	12
146049001	Z 3-3	124
146153001	C 34	6
146197001	W 1-22	94
146202000	A1 18-10	110
	P 128-60	30
146290001	F 25	10
	Z 5	124
147251009	A 7	2
147557101	H 3	14
147777000	B 12-3	4
147846002	C 41	6
148537001	J 14	16
149173001	Z 2-4	124
149287000	Q 39	32
149438000	X 78-1-2	102
149547000	A1 18-9	110
	D3 15-44	120
	D4 16-20	122
	R 48	36
	S 12-3-54	62
	S 13-3-54	70
	S 14-3-54	78
	S 15-3-54	86
	U 19	92
	Y 121	108
149796001	X 17	96
149809000	L 13	18
	Y 72	108
150106003	Z 6-4	124
150145009	Z 25	126
150172003	Z 6-3	124
150173003	Z 6-4-1	124
150174000	Z 6-2-3	124
	Z 6-5	124
150179002	Z 6-7-1	124
150180001	Z 6-8	124
150182000	Z 6-9	124
150185009	Z 25-2	126
150191002	Z 6-2-2	124
150206002	Z 6-2-1	124
150332001	Z 2-5	124
150335001	Z 3-6	124
150349001	Y 80	108
150357001	Y 81	108

CODE	REF.NO.	PAGE
150756009	A 8	2
150826000	S 12-3-55	62
	S 13-3-55	70
	S 14-3-55	78
	S 15-3-55	86
151594001	B 29-3	4
151827000	Y 127	104
151987001	J 16	16
152358001	W 1-5	94
152361001	W 1-10	94
152362001	W 1-11	94
152363001	W 1-15	94
152364001	W 1-17	94
152387000	M 12-1	20
	Z 15	124
152429000	Y 2-16	104
152430000	Y 2-15	104
152507000	W 1-27-2	94
152508000	W 1-27-3	94
152509000	W 1-27-4	94
	X 1-3-5	96
152510000	Y 58	106
152565000	Y 1-10-2	104
	Z 17	126
152593000	M 12	20
152645001	W 1-28	94
152661100	Y 52-2	106
152857001	Q 73	34
152858001	Q 72	34
152859001	Q 71	34
152866001	A 21	2
152867000	A 24	2
152868009	A 23	2
152948001	G 18	12
	G 49	12
153112001	G 41	12
153113001	E 4	8
153252000	X 14-3	96
153274001	X 93-6	102
153596001	B 15	4
154024001	W 1-7	94
154092001	W 1-8	94
154125001	Z 3-8	124
154468001	U 9	92
154560001	H 1-4	14
154567000	J 2	16
154576001	J 15	16
154577001	J 18	16
154578000	J 19	16
154579001	J 21	16
154581001	J 24	16
154582001	J 26	16
154590001	J 27	16
154593001	J 30	16
154594000	J 31	16
154595001	J 32	16
154596000	J 33	16
154598001	J 37	16
154599000	J 38	16
154607001	K 5	18
154702001	Z 7	124
155559001	J 44	16
156112003	Z 6-1	124
156619001	J 9	16
156620000	J 10	16
157840000	G 45	12
157843001	G 38	12

CODE	REF.NO.	PAGE
157844000	G - 39	12
157875000	Y 2-12	104
158597001	W 1-31	94
158598009	W - 1-32	94
158726001	B 12-5	4
158727001	B 12-6	4
159150009	C1 1-4	116
159324001	F 21	10
159486001	C 19	6
159805001	H - 17-6	14
183377001	H - 1	14
183388001	F - 24-1	10
183389001	F - 24-2	10
183390001	F - 24-3	10
183400009	D1- 6	116
183513009	H - 17	14
183532001	F - 17	10
215083001	Y - 104	108
	Y - 106	108
	Y - 108	108
340400001	K - 10	18
525664000	A - 36	2
	T - 59	90
525907000	B1- 98	114
	P - 60	24
	S - 1-1-6	38
	S - 12-1-6	56
	S - 13-1-6	64
	S - 14-1-6	72
	S - 15-1-6	80
	S - 2-1-6	42
	S - 3-1-6	46
	S - 4-1-6	50
	Y - 78	108
552851001	W - 1-27-5	94
552908000	Y - 113	108
554482000	D3- 15-25	120
	D4- 16-7	122
	Q - 96	34
	S - 12-3-56	62
	S - 13-3-56	70
	S - 14-3-56	78
	S - 15-3-56	86
	Y - 54	106

brother

ブラザー工業株式会社

〒467 名古屋市瑞穂区河岸一丁目1番1号
TEL (052) 824-2392代

151-751
195751-101
1991, 04

From the library of: Superior Sewing Machine & Supply Ltd